

REVISIONS				
LETTER	DATE	BY	ECN	DESCRIPTION

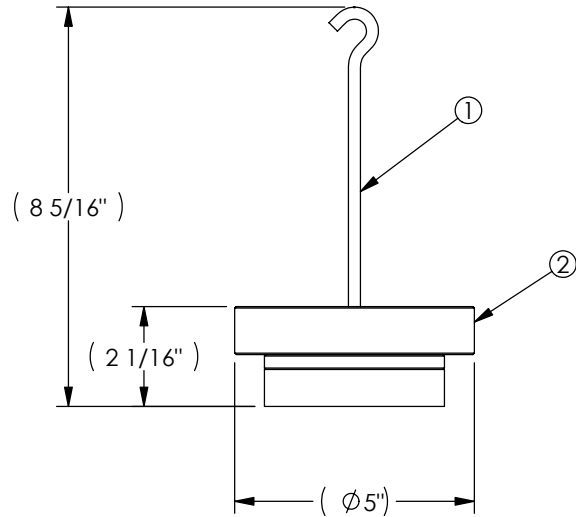

ITEM NO.	PART NUMBER	DESCRIPTION	QTY.
2	51W017	CAL WEIGHT, SLOTTED, 2 kg	1
1	51W016	CAL WEIGHT, HANGER, 1 kg	1

MATERIAL: (CAST IRON)	DESIGN	-	-
	DRAWN	JEF	01/18/07
FINISH: -	CHECKED	-	-
THIRD ANGLE PROJECTION			
<p>THIS DRAWING AND SPECIFICATION CONTAINS PROPRIETARY INFORMATION TO MAGTROL INC. ANY DISCLOSURE OR REPRODUCTION OF THIS DOCUMENT WITHOUT WRITTEN AUTHORIZATION FROM MAGTROL INC. IS EXPRESSLY PROHIBITED</p>			

<p><b>MAGTROL INC.</b> 70 GARDENVILLE PKWY, W. BUFFALO, NEW YORK 14224-1322</p>	TITLE WT-800M, CAL WEIGHT KIT, 3 kg	
	USED ON: - SIMILAR TO: -	REV -
DWG. NO. <b>51W028</b>		REV -
SIZE <b>A</b>	SCALE 1:4	SHEET # 1 OF 1

UNLESS OTHERWISE SPECIFIED:  
DIMENSIONS ARE IN INCHES,  
DIAMETERS CONCENTRIC: .003 TIR,  
FACES PERPENDICULAR: .003  
INTERPRETATION PER ASME  
Y14.5M-1994  
REMOVE ALL BURRS AND BREAK  
SHARP EDGES .005/.010 X 45°, ALL  
INSIDE CORNERS TO BE .02 R MAX.  
TOLERANCES:  
.XX ± .01      FRAC. ± 1/64"  
.XXX ± .005    ANG. ± 1°  
SURFACE FINISH 125 RMS MAX. U.O.S.

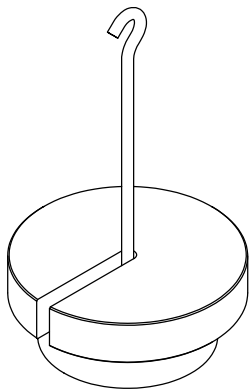

3 DIMENSIONAL VIEW  
SCALE 1 : 4