

WB/PB 2.7 Series Eddy-Current and Powder Dynamometers

FEATURES

- 9 Models with Maximum Torque from 300 mN·m to 2400 mN·m (42 oz-in to 340 oz-in)
- Braking Power: 20 W to 1 kW
- Stable Braking Torque, without Shock
- Low Moment of Inertia
- Low Residual Torque
- Operation in Either Rotational Direction
- Braking Torque Measurement Included
- Optional Speed Measurement
- Rated Torque Available From Zero Speed (Powder Dynamometers)
- Integrated Optical Speed Sensor

DESCRIPTION

Eddy-Current Brake Dynamometers (WB series) are ideal for applications requiring high speeds and also when operating in the middle to high power range. Eddy-Current Brakes provide increasing torque as the speed increases, reaching peak torque at rated speed. The dynamometers have low inertia as a result of small rotor diameter. Brake cooling is provided by a water circulation system, which passes inside the stator to dissipate heat generated by the braking power. The water cooling in the WB provides high continuous power ratings (max. 1 kW).

Powder Brake Dynamometers (PB series) are ideal for applications operating in the low to middle speed range or when operating in the middle to high torque range. Powder Brakes provide full torque at zero speed and are water-cooled, allowing for power ratings up to 600 W. Both WB and PB Dynamometers have typical accuracy ratings of $\pm 0.5\%$ full scale - depending on size and system configuration.

APPLICATIONS

Mounted on test benches, the WB/PB 2.7 Series Dynamometers allow performance and reliability testing on driving elements such as servomotors, micromotors for cameras, small fans, dental drills, geared motors, small reduction gears, pneumatic equipment, hydraulic transmission systems and motors for small domestic appliances.



Model 4 WB-2.7-8K Eddy-Current Dynamometer

MOTOR TESTING SYSTEMS

Magtrol's M-TEST 7 Software is a state-of-the-art motor testing program for Windows®-based data acquisition. Used with a Magtrol DSP7000 Programmable Dynamometer Controller, Magtrol M-TEST 7 Software provides the control of any Magtrol Eddy-Current or Powder Brake Dynamometer and runs test sequences in a manner best suited to the overall accuracy and efficiency of the Magtrol Motor Test System.

The data that is generated by Magtrol's Motor Testing Software can be stored, displayed and printed in tabular or graphic formats, and can be easily imported into a spreadsheet.

Written in LabVIEW™, M-TEST 7 has the flexibility to test a majority of motor types in a variety of ways. Because of LabVIEW's versatility, obtaining data from other sources (e.g. thermocouples), controlling motor power and providing

audio/visual indicators is relatively easy.

Magtrol's M-TEST 7 Software is ideal for simulating loads, cycling the unit under test and motor ramping. Because it is easy to gather data and duplicate tests, the software is ideal for use in engineering labs. Tests can be programmed to run on their own and saved for future use allowing for valuable time savings in production testing and incoming/outgoing inspection.

SINGLE DYNAMOMETER CONFIGURATIONS

The Dynamometers can be complemented by various electronic modules such as the DES 410 Power Supply, TSC 401 Torque/Speed Conditioner and DSP7000 High Speed Programmable Dynamometer Controller.

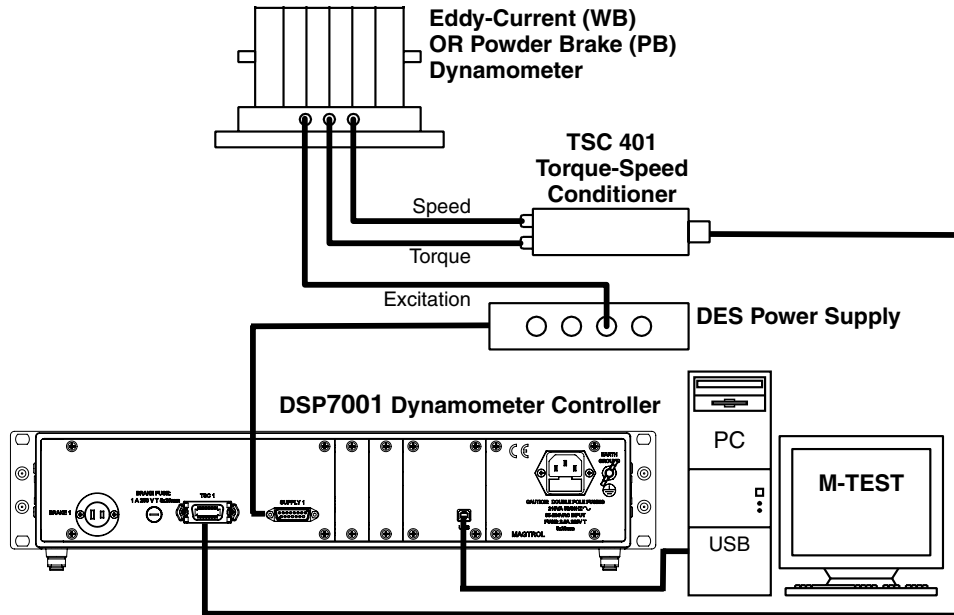

Magtrol also offers In-Line Torque Transducers for extremely accurate torque and speed measurement with high noise immunity. The transducers employ a unique non-contact differential transformer torque measuring technology which prevents the rotation of electronic components during operation, without the usage of sliprings. For a dynamic, high-precision system, the torque transducer can be mounted in line between the unit under test and the dynamometer.

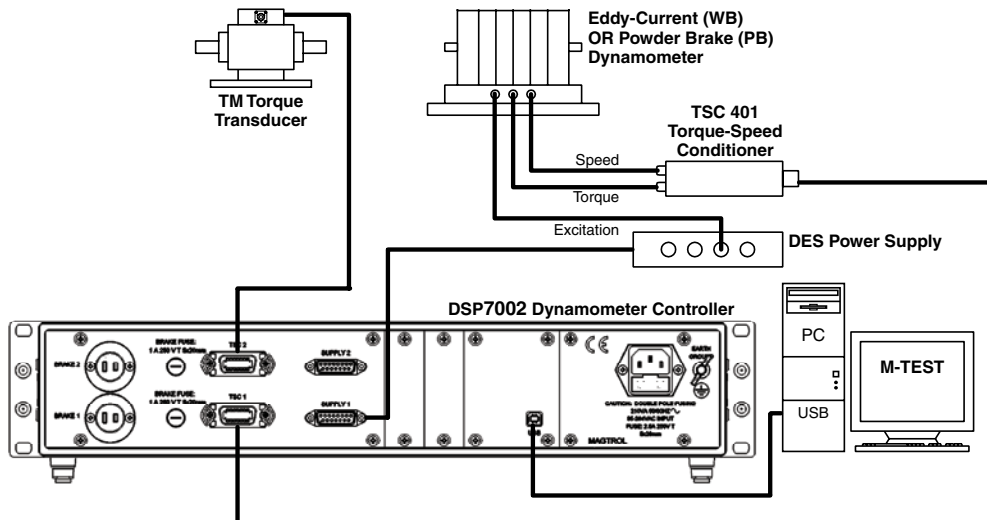

EDDY-CURRENT DYNAMOMETER OPERATING PRINCIPLES

The WB Eddy-Current Dynamometers develop their full power at high rotation speeds. The 2.7 Series is particularly intended

for motors which rotate at high speeds, up to 50,000 rpm. The braking torque depends on the rotation speed.

WB DYNAMOMETER RATINGS

Model	Rated Torque		Drag Torque De-energized		Nominal Input Inertia		Rated Power	Rated Speed	Max. Speed	Excitation Current*
	N·m	oz·in	mN·m	oz·in	kg·m ²	lb·ft·s ²			standard version	
2 WB 2.7-8K	0.30	42.4	9	1.27	2.33×10^{-5}	1.71×10^{-5}	500	15,915	50,000	1.0
3 WB 2.7-8K	0.45	63.7	9	1.27	3.18×10^{-5}	2.34×10^{-5}	750	15,915	50,000	1.5
4 WB 2.7-8K	0.60	84.9	12	1.69	4.03×10^{-5}	2.97×10^{-5}	1000	15,915	50,000	2.0

* Voltage at 20 °C is 15 volts.

Optical Speed Sensor

Each 2.7 Series WB Dynamometer has an optical speed sensor with a 30-bit pulse wheel delivered as standard.

Cooling Water Consumption

For all WB models: ≈ 30 l/kWh at $\Delta t = 30$ °C (Metric)
 ≈ 8 gal/kWh at $\Delta t = 86$ °F (US)

WB TORQUE-SPEED-POWER CURVES

The diagram below shows the characteristic curves for the 2.7 Series Eddy-Current Dynamometers.

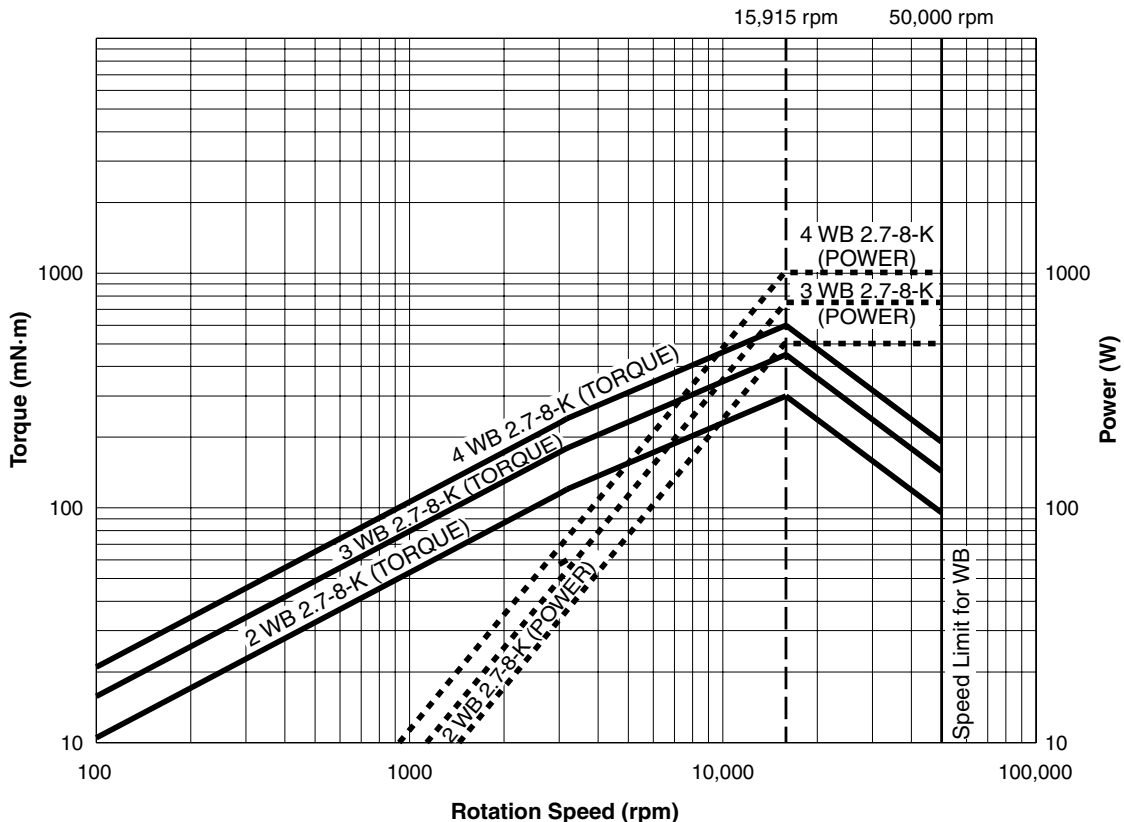

POWDER DYNAMOMETER OPERATING PRINCIPLES

The PB Powder Dynamometers contain, as their name suggests, a magnetic powder. The electrical current passing through the coil generates a magnetic field, which changes the property of the powder, thus producing a smooth braking

torque through friction between rotor and stator. The Powder Dynamometers (PB) produce their rated torque at zero speed. The element to be tested can be loaded at standstill to determine the starting torque.

PB DYNAMOMETER RATINGS

Model	Rated Torque		Drag Torque De-energized		Nominal Input Inertia		Rated Power	Rated Speed	Max. Speed	Excitation Current*
	<i>N·m</i>	<i>oz·in</i>	<i>mN·m</i>	<i>oz·in</i>	<i>kg·m²</i>	<i>lb·ft·s²</i>	<i>W</i>	<i>rpm</i>	<i>rpm</i>	<i>A</i>
1 PB 2.7-8	0.6	84	18	2.54	1.49×10^{-5}	1.09×10^{-5}	20	320	3000	0.5
2 PB 2.7-8	1.2	169	30	4.24	2.33×10^{-5}	1.71×10^{-5}	40	320	3000	1
4 PB 2.7-8	2.4	339	48	6.79	4.03×10^{-5}	2.97×10^{-5}	80	320	3000	2
1 PB 2.7-8K **	0.6	84	18	2.54	1.49×10^{-5}	1.09×10^{-5}	150	2390	10,000	0.5
2 PB 2.7-8K **	1.2	169	30	4.24	2.33×10^{-5}	1.71×10^{-5}	300	2390	10,000	1
4 PB 2.7-8K **	2.4	339	48	6.79	4.03×10^{-5}	2.97×10^{-5}	600	2390	10,000	2

* Voltage at 20 °C is 24 volts.

Optical Speed Sensor

Each 2.7 Series PB Dynamometer has an optical speed sensor with a 30-bit pulse wheel delivered as standard.

** Cooling Circuit

The 2.7 Series PB Dynamometers are available with (K) or without a cooling circuit. The cooling water consumption for all PB-8K models is: ≈ 30 l/kWh at $\Delta t = 30$ °C (Metric)
 ≈ 8 gal/kWh at $\Delta t = 86$ °F (US)

PB TORQUE-SPEED-POWER CURVES

The diagrams below shows the characteristic curves for the 2.7 Series Powder Dynamometers.

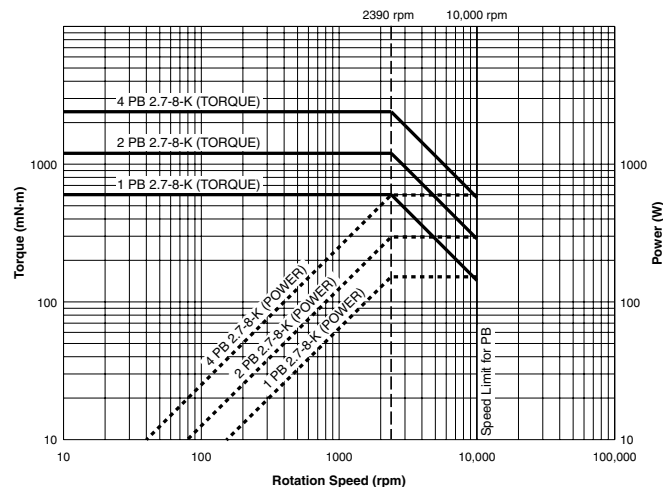
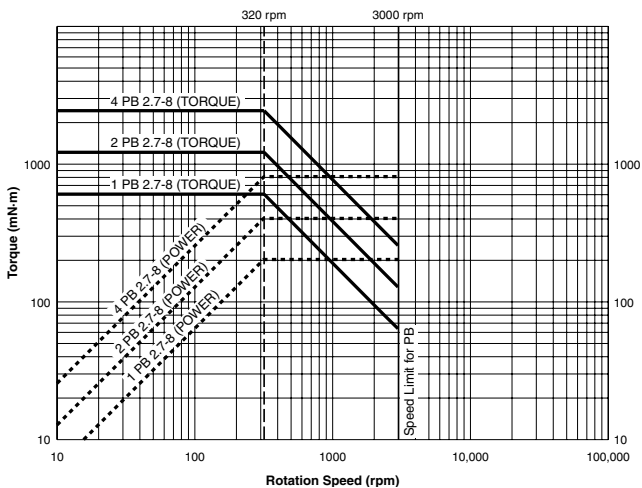

DYNAMOMETERS WITH COOLING CIRCUIT

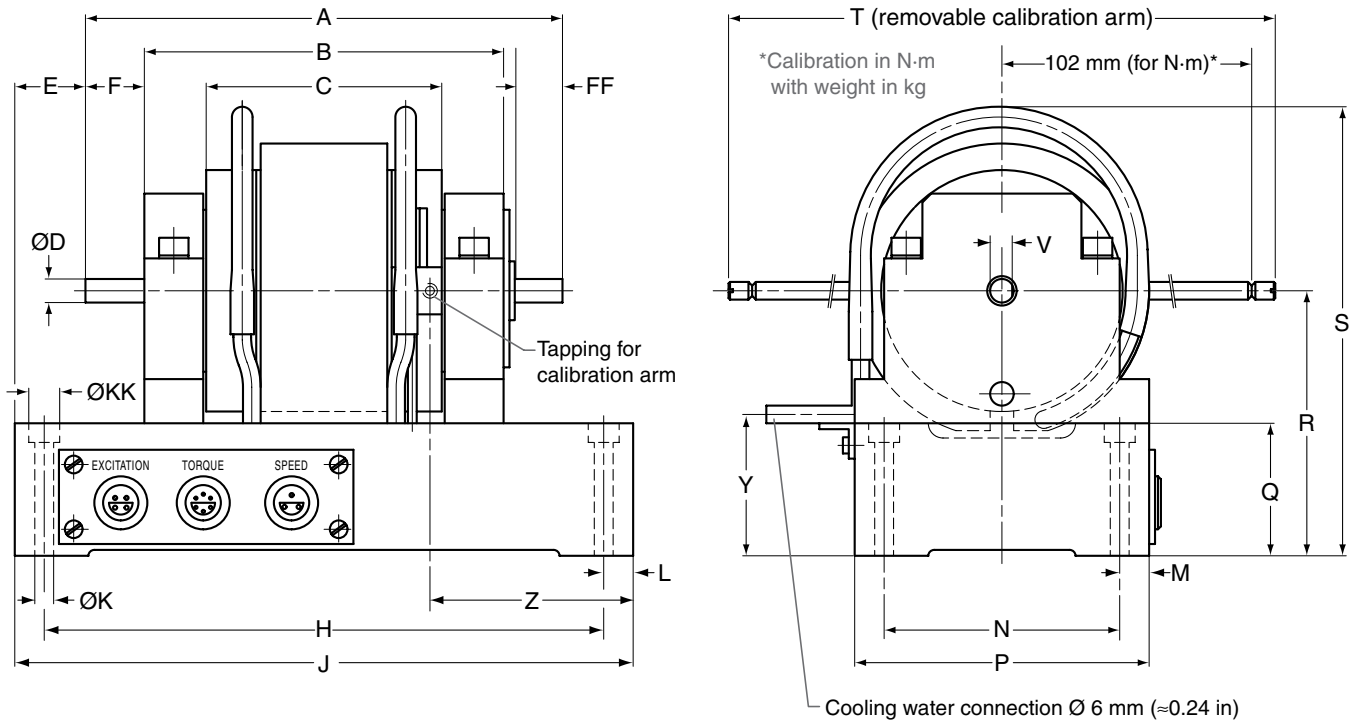

NOTE:

Original dimensions are in Metric units. Dimensions converted to English units have been rounded up to 2 decimal places.

Model	units	A	B	C	D	E	F	H	J	K	L	M
1 PB 2.7-8-K	mm	138	98	56	Ø 8h5	36	20	190	210	Ø 6.4	10	10
	in	5.43	3.86	2.2	Ø 0.3148 0.3149	1.42	0.79	7.48	8.27	Ø 0.252	0.39	0.39
2 WB 2.7-8-K / 2 PB 2.7-8-K	mm	162	122	80	Ø 8h5	24	20	190	210	Ø 6.4	10	10
	in	6.38	4.8	3.15	Ø 0.3148 0.3149	0.94	0.79	7.48	8.27	Ø 0.252	0.39	0.39
3 WB 2.7-8-K	mm	186	146	104	Ø 8h5	12	20	190	210	Ø 6.4	10	10
	in	7.32	5.75	4.09	Ø 0.3148 0.3149	0.47	0.79	7.48	8.27	Ø 0.252	0.39	0.39
4 WB 2.7-8-K / 4 PB 2.7-8-K	mm	210	170	128	Ø 8h5	---	20	190	210	Ø 6.4	10	10
	in	8.27	6.69	5.04	Ø 0.3148 0.3149	---	0.79	7.48	8.27	Ø 0.252	0.39	0.39

Model	units	N	P	Q	R	S	T	V	Y	Z	FF	KK	Weight
1 PB 2.7-8-K	mm	80	100	45	90 ±0.1	152	220	7.6	48	81	16	Ø 10.5	4.2 kg
	in	3.15	3.94	1.77	3.547 3.539	5.98	8.66	0.299	1.89	3.19	0.63	Ø 0.413	9.26 lb
2 WB 2.7-8-K / 2 PB 2.7-8-K	mm	80	100	45	90 ±0.1	152	220	7.6	48	69	16	Ø 10.5	5.3 kg
	in	3.15	3.94	1.77	3.547 3.539	5.98	8.66	0.299	1.89	2.72	0.63	Ø 0.413	11.68 lb
3 WB 2.7-8-K	mm	80	100	45	90 ±0.1	152	220	7.6	48	57	16	Ø 10.5	6.4 kg
	in	3.15	3.94	1.77	3.547 3.539	5.98	8.66	0.299	1.89	2.24	0.63	Ø 0.413	14.11 lb
4 WB 2.7-8-K / 4 PB 2.7-8-K	mm	80	100	45	90 ±0.1	152	220	7.6	48	45	16	Ø 10.5	7.5 kg
	in	3.15	3.94	1.77	3.547 3.539	5.98	8.66	0.299	1.89	1.77	0.63	Ø 0.413	16.53 lb

DYNAMOMETERS WITHOUT COOLING CIRCUIT

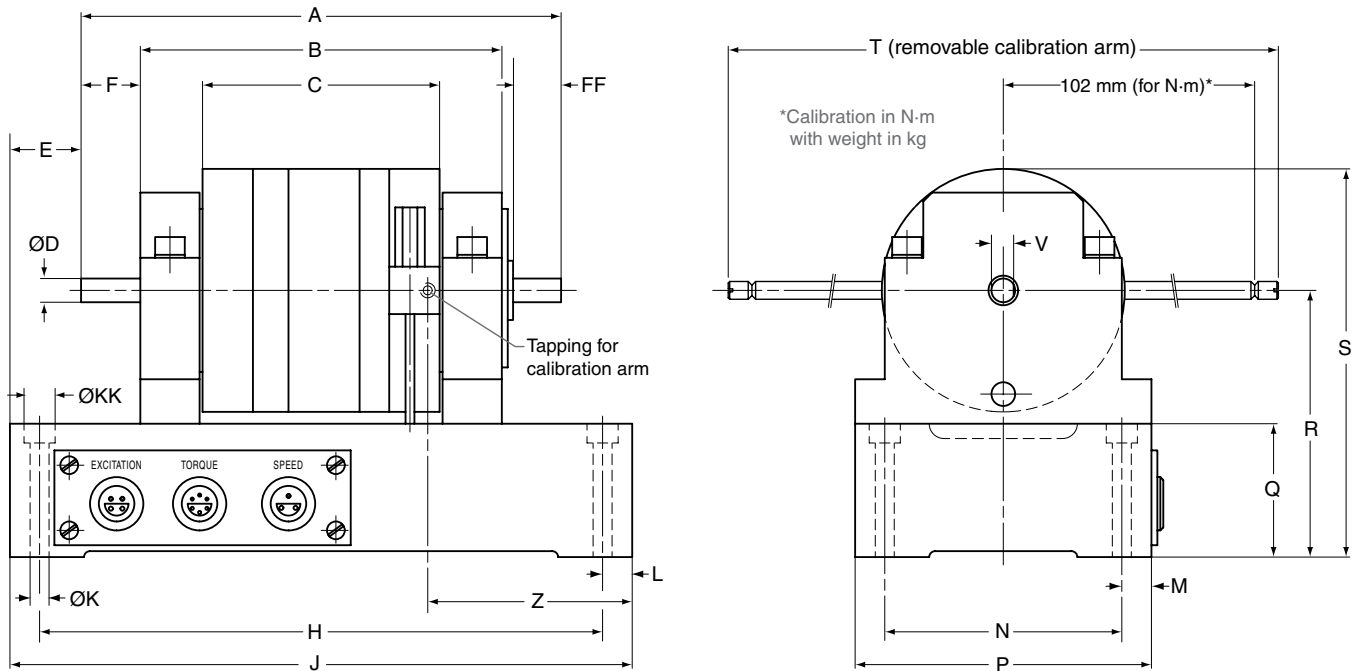

NOTE:

Original dimensions are in Metric units. Dimensions converted to English units have been rounded up to 2 decimal places.

Model	units	A	B	C	D	E	F	H	J	K	L	M
1 PB 2.7-8	mm	138	98	56	Ø 8h5	36	20	190	210	Ø 6.4	10	10
	in	5.43	3.86	2.2	Ø 0.3148 0.3149	1.42	0.79	7.48	8.27	Ø 0.252	0.39	0.39
2 PB 2.7-8	mm	162	122	80	Ø 8h5	24	20	190	210	Ø 6.4	10	10
	in	6.38	4.8	3.15	Ø 0.3148 0.3149	0.94	0.79	7.48	8.27	Ø 0.252	0.39	0.39
4 PB 2.7-8	mm	210	170	128	Ø 8h5	---	20	190	210	Ø 6.4	10	10
	in	8.27	6.69	5.04	Ø 0.3148 0.3149	---	0.79	7.48	8.27	Ø 0.252	0.39	0.39

Model	units	N	P	Q	R	S	T	V	Z	FF	KK	Weight
1 PB 2.7-8	mm	80	100	45	90 ±0.1	131	220	7.6	81	16	Ø 10.5	3.8 kg
	in	3.15	3.94	1.77	3.547 3.539	5.16	8.66	0.299	2.72	0.63	Ø 0.413	8.38 lb
2 PB 2.7-8	mm	80	100	45	90 ±0.1	131	220	7.6	69	16	Ø 10.5	4.6 kg
	in	3.15	3.94	1.77	3.547 3.539	5.16	8.66	0.299	3.19	0.63	Ø 0.413	10.14 lb
4 PB 2.7-8	mm	80	100	45	90 ±0.1	131	220	7.6	45	16	Ø 10.5	6.2 kg
	in	3.15	3.94	1.77	3.547 3.539	5.16	8.66	0.299	2.72	0.63	Ø 0.413	13.67 lb

DYNAMOMETER OPTIONS

Vertical Mounting (V)

Vertical Mounting is available on the Eddy-Current (WB) Dynamometer only. The vertical version has an adapted bearing fitting and its maximum speed is limited.

Mechanical Rotor Blocking Device (MB)

A mechanical rotor blocking device, which allows locked rotor testing, is available for the WB Dynamometer.

DYNAMOMETER MODELS

Eddy-Current	Powder with Cooling Circuit	Powder without Cooling Circuit
2 WB 2.7-8K	1 PB 2.7-8K	1 PB 2.7-8
3 WB 2.7-8K	2 PB 2.7-8K	2 PB 2.7-8
4 WB 2.7-8K	4 PB 2.7-8K	4 PB 2.7-8

ORDERING INFORMATION

If one of the listed options is desired, please follow the dynamometer model (see table above) with a dash and then the appropriate suffix (as noted in parenthesis). For example, a Model 1 WB 2.7-8K Eddy-Current Dynamometer with a maximum speed rating of 70,000 rpm is a 1 WB 2.7-8K-HS.

Example: **1 WB 2.7-8K - HS**
└───┬───┘ └─┘
Dynamometer Model Option

SYSTEM OPTIONS AND ACCESSORIES

	DESCRIPTION	MODEL / PART #
ELECTRONICS	High Speed Programmable Dynamometer Controller	DSP7000
	Torque-Speed Conditioner (includes necessary cables)	TSC 401/111
	Power Supply (includes necessary cables)	DES 410/111
	High Speed Single-Phase Power Analyzer	6510 _e
	High Speed Three-Phase Power Analyzer	6530
SOFT-WARE	M-TEST 7 Motor Testing Software	M-TEST 7
	Temperature Testing Hardware	HW-TTEST
MISC	Couplings, Thermostatic Sluice, Pressure Sensitive Switch	On Request
	Water Cooling System for Brake	On Request
	Calibration Weights	On Request

Due to the continual development of our products, we reserve the right to modify specifications without forewarning.



www.magtrol.com

MAGTROL INC

70 Gardenville Parkway
 Buffalo, New York 14224 USA
 Phone: +1 716 668 5555
 Fax: +1 716 668 8705
 E-mail: magtrol@magtrol.com

MAGTROL SA

Route de Montena 77
 1728 Rossens/Fribourg, Switzerland
 Phone: +41 (0)26 407 3000
 Fax: +41 (0)26 407 3001
 E-mail: magtrol@magtrol.ch

Subsidiaries in:

Germany • France
 China • India
 Worldwide Network
 of Sales Agents

