

1. EXTERNAL ENCODER INSTALLATION PROCESS

If using an external encoder, you must connect it to the SBB15. Please, follow the instructions below:

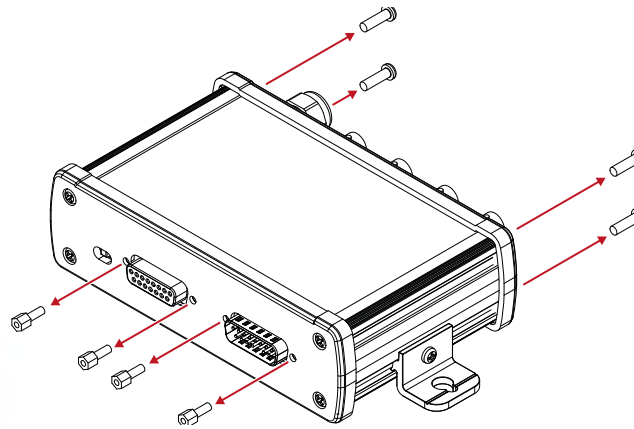

1. On the front, remove the 4 standoffs securing the 15-pin D-Sub connectors.
2. On the back, remove the 4 screws securing the box.

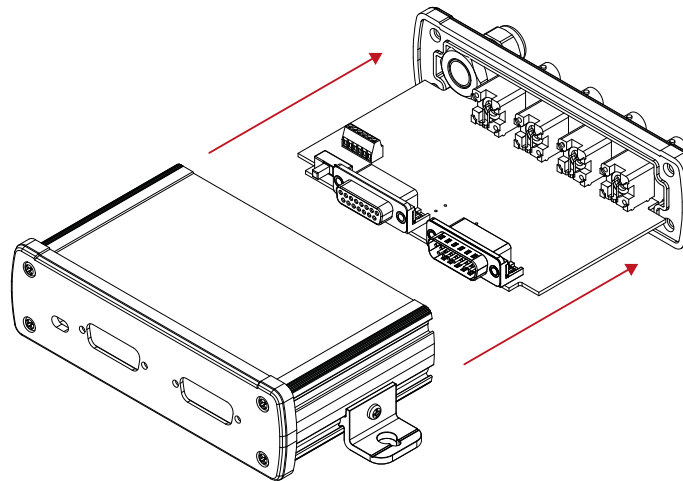

3. Open the box from the BNC side

External Encoder Wiring

⊥: GND
B: Tach B
A: Tach A
+: +5V
-: 5V COM
: Index

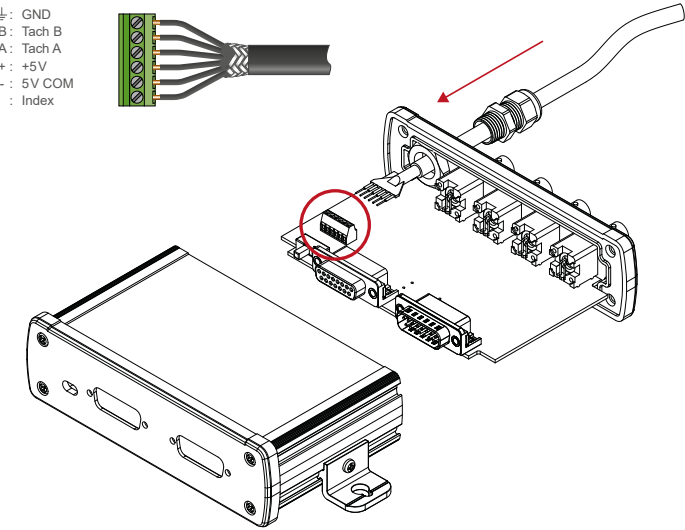

4. Insert the cable from the external encoder through the dedicated cable gland.
5. Connect the cable to the connector according to the External Encoder Wiring Diagram above.

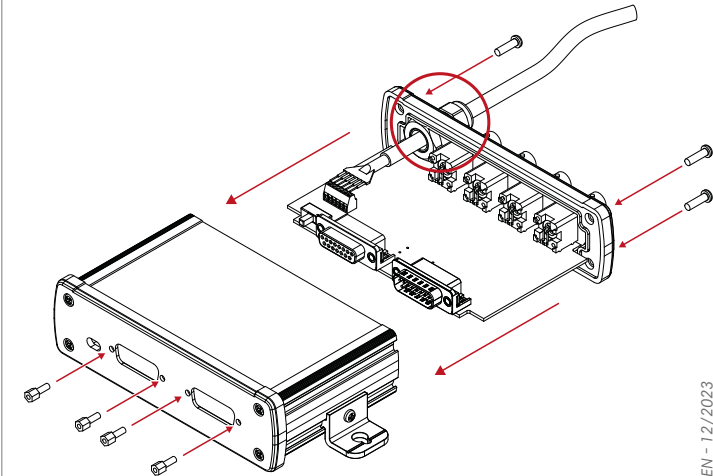

6. Finish securing the cable gland and reassemble the box.

SBB 15

SIGNAL BREAKOUT BOX

EXTERNAL ENCODER INSTALLATION INSTRUCTIONS

For further information, please consult the product data sheet. The document is available for download from our website: www.magtrol.com.

©2023 MAGTROL | Due to continual product development, Magtrol reserves the right to modify specifications without forewarning.