

AC89@	GC7? 7C89	A-B-AIA HCFE195H F5H8 71FF9BHfBa L	F5H8 71FF9BH fa 5L	F9G-5B79 -%\$ 4 & 57 ft\ a g	JC@E; 9 fj XVŁ	BCA-B5@ DCK 9F fk Ultjt	A5L-AIA GD998 ffDA Ł	?B9H7 DCK 9F F5HB; G			899B9F; #98 8F5; HCFE19 4 %\$\$\$FDA fa Ba Ł	9LHFB5@ -B9FH5 fll 'Wa Ł	HCFE19HC -B9FH5 F5HC ffUX#gŁ
5<6!\$"	\$\$*)'	\$" \$	' \$\$	-\$	&+	, "%\$	&) Z\$\$\$	*&\$-')) \$\$) \$\$) "\$	\$"% '	% " * ' 1 %\$
								BC '5 F	-\$	&)			

GC@8'A C89@5J 5-6@

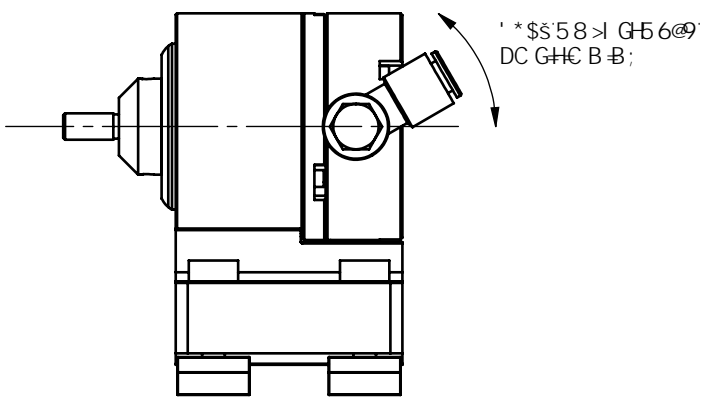
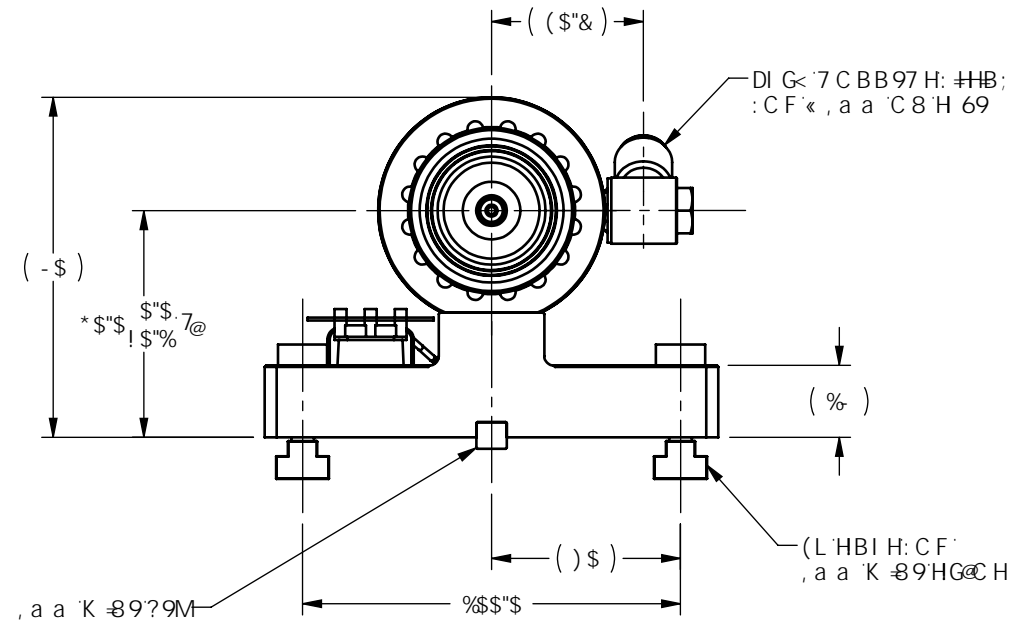
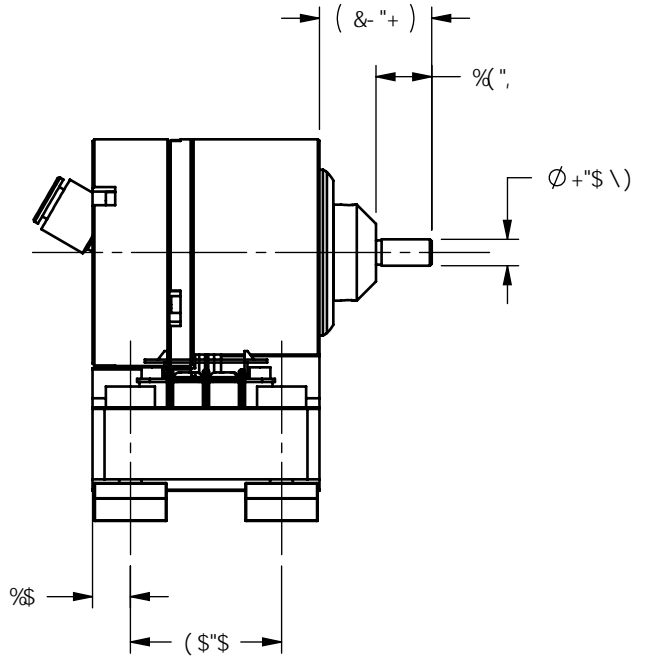
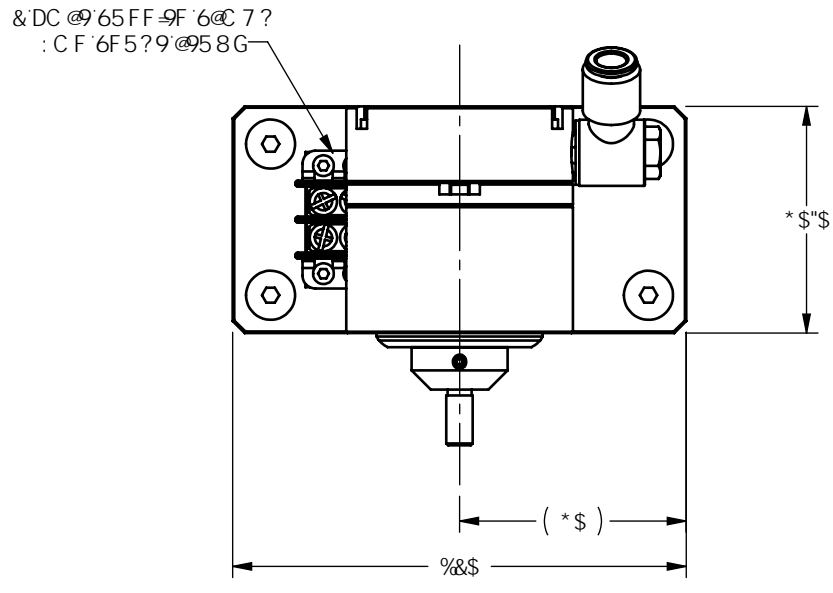
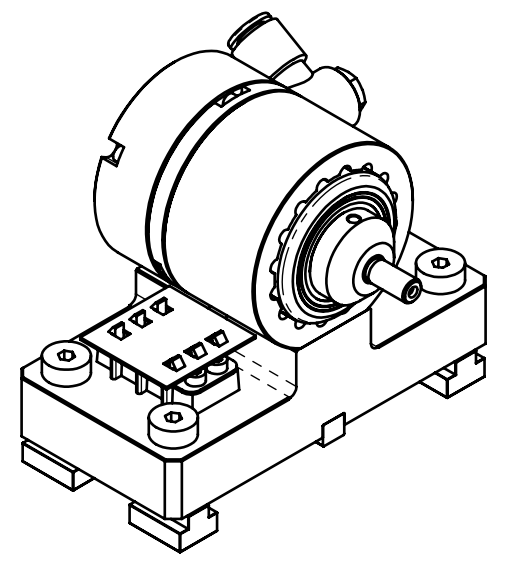

BG5@5HC B'8F5K -B;

HMD-7 5@GC I B8 'DF9GG F9'5H%A 9HF. fh68EXV
 K 5FB-B; . '< & ' < GC I B8 @J 9@G7 5B'7 5I G9
 D9FA 5B9BH<95F-B; '@ GG''1 G9<95F-B;
 DFC H97 HC B'K <@H: GDFC 8I 7 H-G-B'1 G9'



A 5Hf-5@	! 89G= B	>9;	\$, #% #-\$-	<p>A 5; HFC@B7" +\$; 5F89BJ @D?K MŁK " 6I :: 5@ZB9K 'MCF?%'&&(1%&&</p>
:B-G<	! 8F5K B	>9;	\$, #&+ #-\$-	
	7 <97?98	8HK #5>7	\$- #S&#-\$-	
Hk-F8 5B; @ DFC >97 HC B				I B@GGC H: 9FK -G9GD97 =-98. 8-A 9BG@BG5F9-B'A @A 9HFG 8-5A 9HFG7CB7 9H F7. "\$, 'HF : 57 9GD9FD9B8-71 @F. "\$, -BHFD9H5HC B 'D9F '5GA 9 'M(') A 1%- (- F9A C J 9'5@6I FFG5B8 '6F95? "G<5FD'98; 9G\$%" #S"&) L'()S -BG897CFB9FGHC '69F '\$") A 5L HC @F5B7 9G "L - "8) L' - "("LL - "% LS - "%\$ G I: 579: -B@<" "&+a A 5L
Hk-G8F5K-B; 5B8 GD97 =7 5HC B 7CBH5-BGDFCDF-95FMB: CFA 5HC B HC A 5; HFC@B7""5BM8-67 @G F9 CF F9DFC 8I 7HC B' C: H-G8C7I A 9BH K #C I HK F H9B 5I H:CF#5HC B : FC A A 5; HFC@B7""G9LDF9GG@MDFC <-6H98	I G9B CB. ! GA #5F 1E. <6I) SA BK: BC.			\$" 'Ba ž5F'7CC@98' <MGH9F 9G-G'6F5?9 5 <6!\$" 7
	6	%'	G-99H.	