

# 5502/5503

## MANUAL DYNAMOMETER SWITCH BOX

### DESCRIPTION

Magtrol Models 5502 and 5503 are manually-operated switch boxes that permit the connection of up to three Magtrol Dynamometers to a single Dynamometer Controller. Use of the switch boxes facilitates quick and easy interfacing to multiple dynamometers without the need to disconnect and reconnect the brake and control cables. For Magtrol WB Eddy-current or PB Powder Brake Dynamometers, BOTH a 5502 AND a 5503 Switch Box are necessary. Magtrol HD or ED Hysteresis Dynamometers only require the 5502.



Fig.1 : 5502 Manual Dynamometer Switch Box

### CONFIGURATION

#### 5502 CONFIGURATION

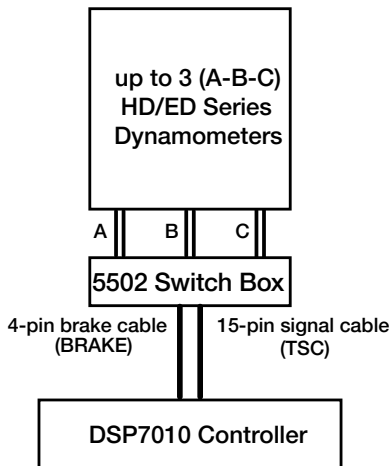

#### 5503 CONFIGURATION

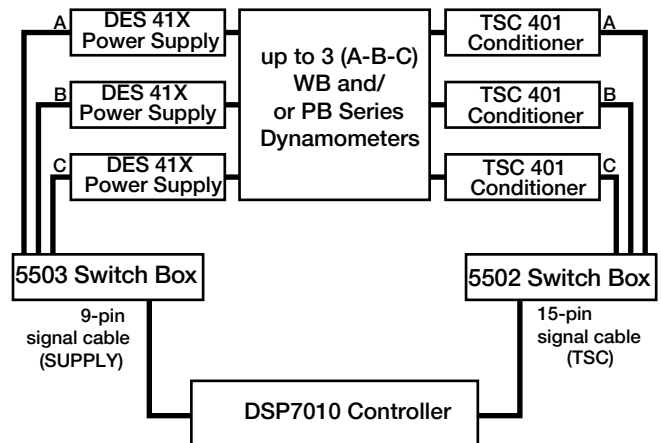

#### 5502 REAR PANEL



#### 5503 REAR PANEL



**SPECIFICATIONS**

| CONNECTION |                     |                             |
|------------|---------------------|-----------------------------|
| MODEL      | OPTIONAL CABLE(S)   | DSP CONNECTION              |
| 5502       | 4-pin brake cable   | To Brake Input (HD/ED only) |
|            | 15-pin signal cable | To TSC Connector            |
| 5503       | 9-pin signal cable  | To Supply Connector         |

| DIMENSIONS |        |         |
|------------|--------|---------|
| Width      | 485 mm | 19.0 in |
| Depth      | 240 mm | 8.5 in  |
| Height     | 50 mm  | 2.0 in  |

NOTE: The 5502/5503 may be used in standard 19" rack (1U). The units may also be used on benchtop- rack mounts can be removed if desired.

**ORDERING INFORMATION**

| DYNAMOMETER TYPE | SWITCH BOX    |
|------------------|---------------|
| HD/ED Hysteresis | 5502 only     |
| WB Eddy-current  | 5503 and 5502 |
| PB Powder        | 5503 and 5502 |

**OPTIONAL CABLES**

| DESCRIPTION                              | LENGTH | PART NUMBER |
|--|--------|-------------|
| Circular M12-4P(M) to Circular M12-4P(F) | 1.5 m  | 88M367-0150 |
|  | 5.0 m  | 88M367-0500 |
| D-Sub 15(M) to D-Sub 15(F)               | 1.5 m  | 88M368-0150 |
|  | 5.0 m  | 88M368-0500 |
| D-Sub 9(M) to D-Sub 9(F)                 | 1.5 m  | 88M411-0150 |
|  | 5.0 m  | 88M411-0500 |

NOTE: Cables sold separately.

**LEGACY CABLES**

If you purchased Magtrol equipment prior to 2022 you may need a legacy cable to connect to the 5502/5503 Switch box. Please contact our Magtrol sales team or visit [magtrol.com/cables](http://magtrol.com/cables).

| DESCRIPTION                    | LENGTH | PART NUMBER |
|--------------------------------|--------|-------------|
| Circular M12-4P(M) to 2(F)-Pin | 1.5 m  | 88M369-0150 |
|                                | 5.0 m  | 88M369-0500 |
| Circular M12-4P(F) to 2(M)-Pin | 1.5 m  | 88M370-0150 |
|                                | 5.0 m  | 88M370-0500 |
| D-Sub 15(M) to 14(M)-Pin       | 1.5 m  | 88M371-0150 |
|                                | 5.0 m  | 88M371-0500 |
| D-Sub 15(F) to 14(M)-Pin       | 1.5 m  | 88M372-0150 |
|                                | 5.0 m  | 88M372-0500 |

NOTE: Cables sold separately.