

THE INFORMATION DISCLOSED HEREIN WAS ORIGINATED BY AND IS THE PROPERTY OF MAGTROL SA. MAGTROL SA RESERVES ALL PATENT PROPRIETARY, DESIGN, USE, SALE, MANUFACTURING AND REPRODUCTION RIGHTS THERETO.

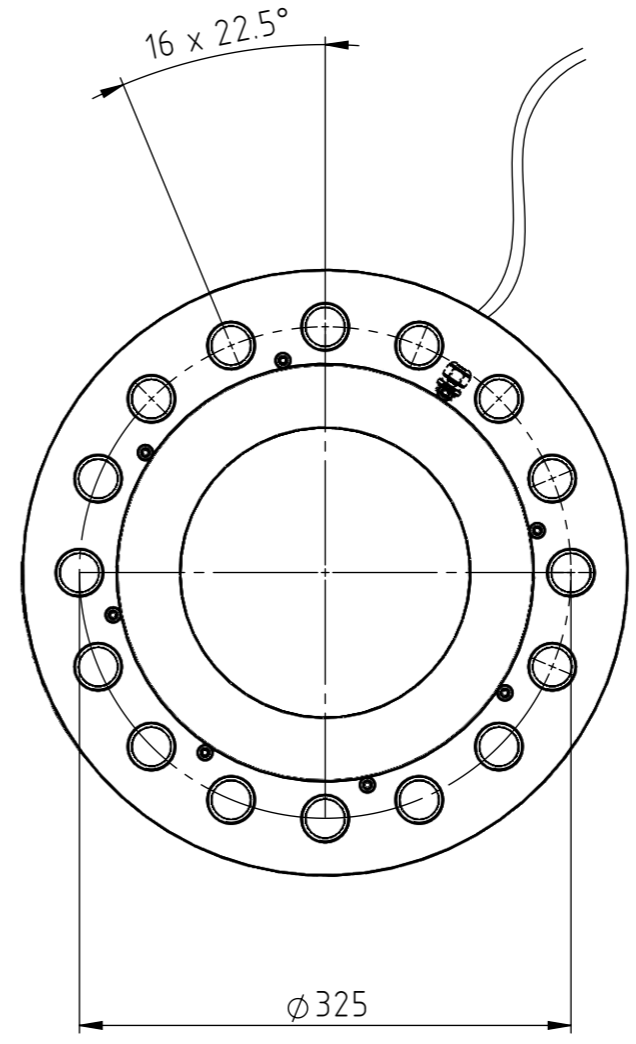

Color code:
 Supply + : Red
 Supply - : Blue
 Signal + : White
 Signal - : Green
 Shield

Nominal Torque: 100 kNm
 Sensitivity: ca. 0.5 mV/V/Nom Torque
 Impedance: 700 Ohm
 Screws: 16 x M30 (12.9)
 Screwing torque: 2662 Nm

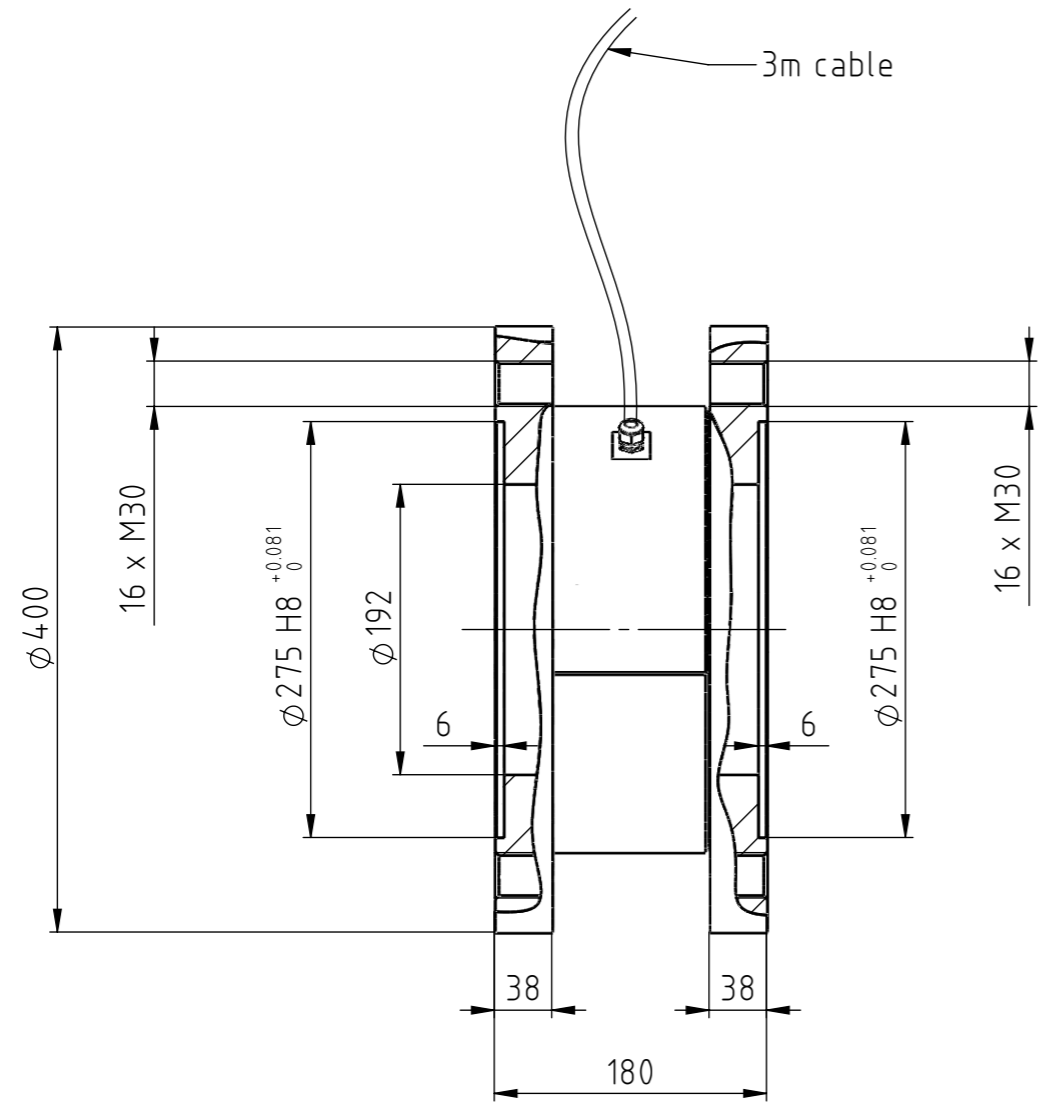
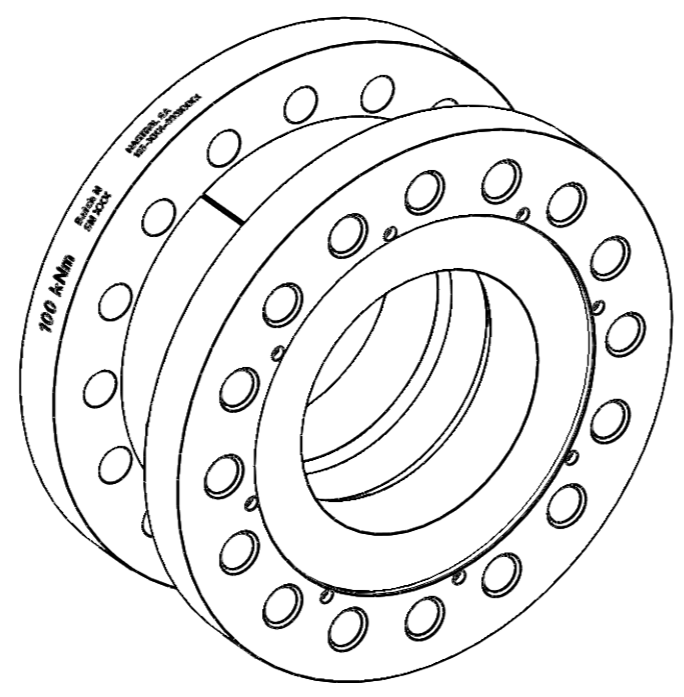

6									
5									
4									
3									
2									
1									
Rev.	Date	PM	Drawn	Appr.	Repl. by :				
					Repl. for :				
Tolerances: ± . . mm to 50mm, ± . . mm over 50mm									
Material: Stainless steel									
Finish:									
Reaction Torquemeter 100 kNm						DRAWING N°			
RT 120						125-120-000V011			



 Scale 1:10

Drawn	08.08.18	ygre
Checked	08.08.18	ajoy
Approved	08.08.18	ygre