

THE INFORMATION DISCLOSED HEREIN WAS ORIGINATED BY AND IS THE PROPERTY OF MAGTROL SA. MAGTROL SA RESERVES ALL PATENT PROPRIETARY, DESIGN, USE, SALE, MANUFACTURING AND REPRODUCTION RIGHTS THERETO.

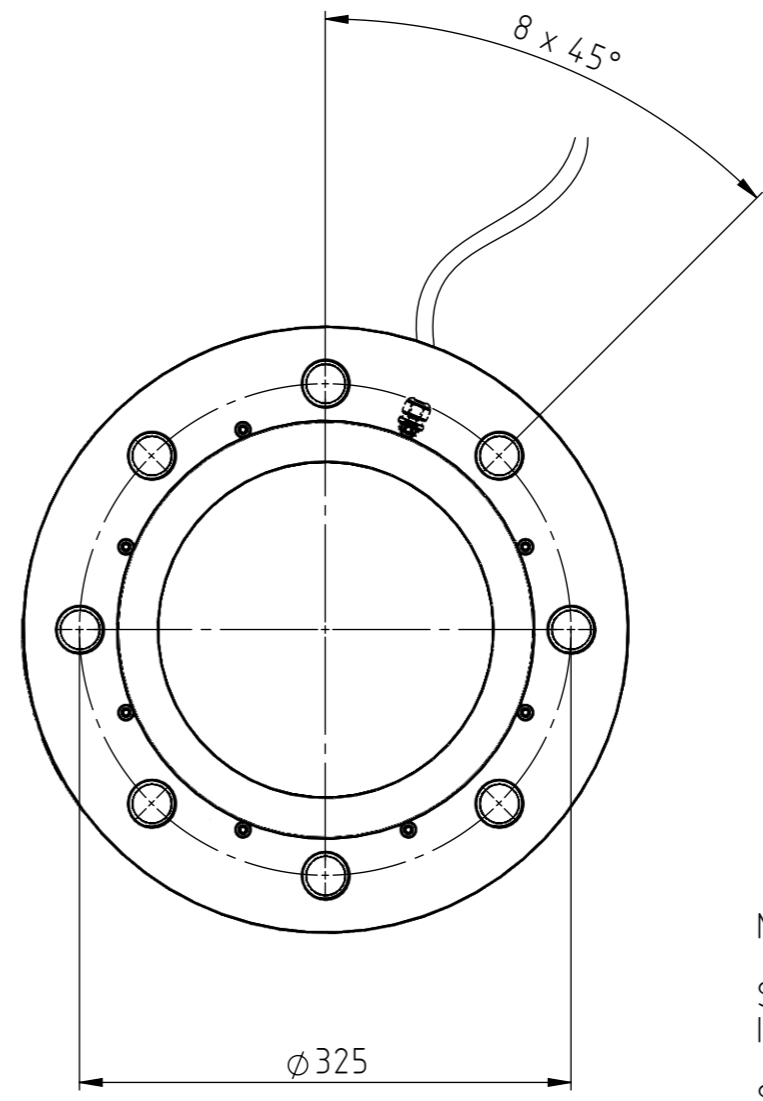

Color code:  
 Supply + : Red  
 Supply - : Blue  
 Signal + : White  
 Signal - : Green  
 Shield

Nominal Torque: 20 / 50kNm  
 Sensitivity: 0.5 mV/V/Nom .Torque  
 Impedance: 700 Ohm  
 Screws: 8 x M30 (12.9)  
 Screwing torque: 2662 Nm

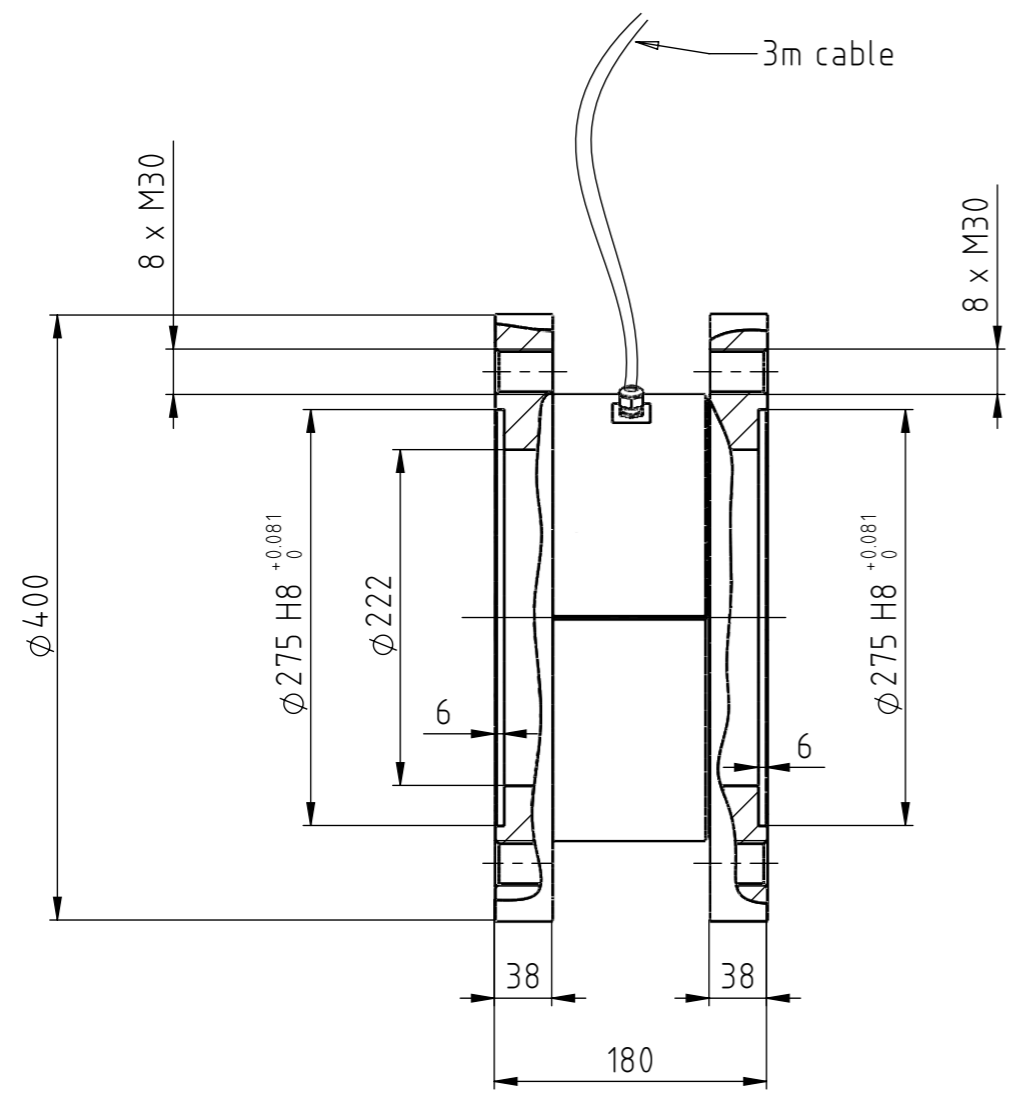
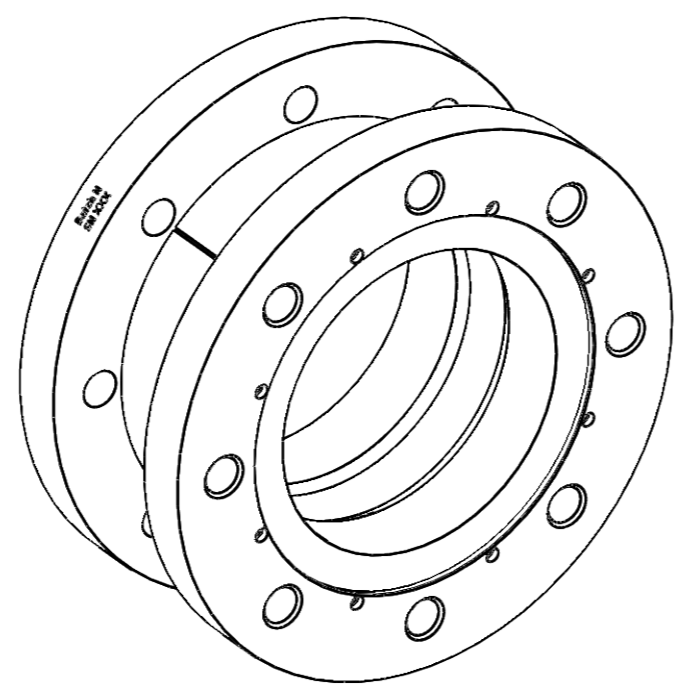

6									
5									
4									
3									
2									
1									
Rev.	Date	PM	Drawn	Appr.	Repl. by :				
					Repl. for :				
Tolerances: ± . mm to 50mm, ± . mm over 50mm									
Material: Stainless steel									
Finish:									
Reaction Torquemeter 20/50 kNm						DRAWING N°			
RT 118 / 119						125-118-000V011			

  
 Scale: 1:10  
 Drawn: 08.08.18 ygre  
 Checked: 08.08.18 ajoy  
 Approved: 08.08.18 ygre