

# RT-100 SERIES

## REACTION TORQUE SENSORS

### FEATURES

- Torque Range: 200 N·m ... 100 kN·m (or more)
- High accuracy 0.05 % ... 0.2 %
- Overload capacity: up to 200 %
- Compact and robust
- High torsional stiffness
- Protection class: IP65
- Center through hole
- Specific design available on request



Fig. 1: RT 114 | Reaction Torque Sensor

### DESCRIPTION

With its compact, robust and maintenance-free design, the Magtrol RT 100 Series Reaction Torque Sensor has many favorable features. Based on strain-gauge technology, the RT Sensor provides highly accurate signal transmission. The RT 100 Series Torque Sensor has been designed to perform static torque measurement and dynamic rotation (with limited angle) in both clockwise and counterclockwise direction with high precision.

The sensor measures small-reaction torque levels using flange-to-flange connections in-line with the component under test. Its design with a center through hole allows the pass through of a shaft, cables or pipes. Main field applications include actuator and valve testing, fastener testing, pump testing and automotive braking.

### SYSTEM CONFIGURATION

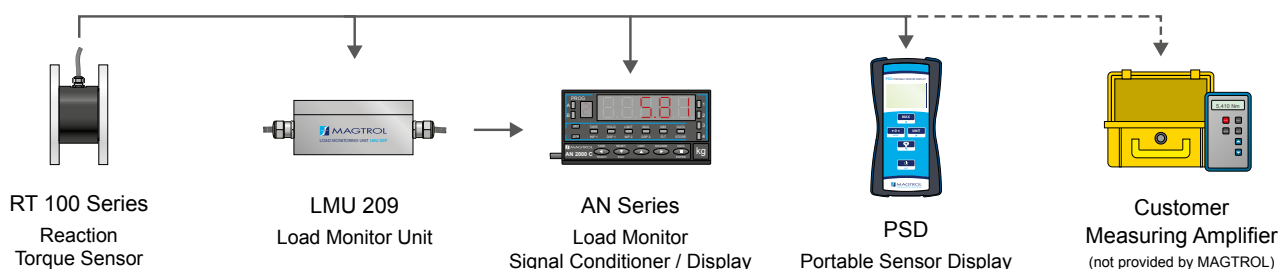

SPECIFICATIONS

TORQUE RATINGS

MODEL	STATIC RATED TORQUE (RT)	COMBINED ERROR (Linearity + Hysteresis)	OVERLOAD CAPACITY	MAX. STATIC TORQUE	BENDING MOMENT MAX	MAX AXIAL LOAD (AL) <sup>a)</sup>	MAX LATERAL LOAD (LL) <sup>a)</sup>	TORSIONAL STIFFNESS	TORQUE OUTPUT SIGNAL	
	N·m	%	% of RT	% of RT	kN·m	kN	kN	N·m / rad	mV / VDC	
RT 112	200	0.05	200	400	0.1	30	6	90.7 x 10 <sup>3</sup>	1.0	
RT 113	500				0.25	40	15	247 x 10 <sup>3</sup>		
RT 114	1000				0.5	70	18	528 x 10 <sup>3</sup>		
RT 115	2000				1.0	80	35	1.11 x 10 <sup>6</sup>		
RT 116	5000	0.10		350	2.5	150	70	2.65 x 10 <sup>6</sup>		
RT 117	10000				5.0	90	60	5.77 x 10 <sup>6</sup>		
RT 118	20000	0.20		400	12.0	600	300	50 x 10 <sup>6</sup>		0.5
RT 119	50000				25.0		1000	750		
RT 120	100000		50.0		1100	142 x 10 <sup>6</sup>		~0.5		

MECHANICAL CHARACTERISTICS

Material	Stainless Steel
----------	-----------------

ENVIRONMENT

Nominal temperature range	+20 °C... +60 °C
Service temperature range	-20 °C... +85 °C
Reference temperature	+23 °C
Temperature influence on zero	0.01 % / °C
Temperature influence on sensitivity	0.01 % / °C
Protection class	IP 65

INPUT AND OUTPUT SIGNALS

Input resistance	700 Ω
Insulation resistance	10 GΩ
Power supply	0.5... 12VDC (max. 15VDC)
Torque output signal <sup>b,c)</sup>	See below the "Torque rating" table

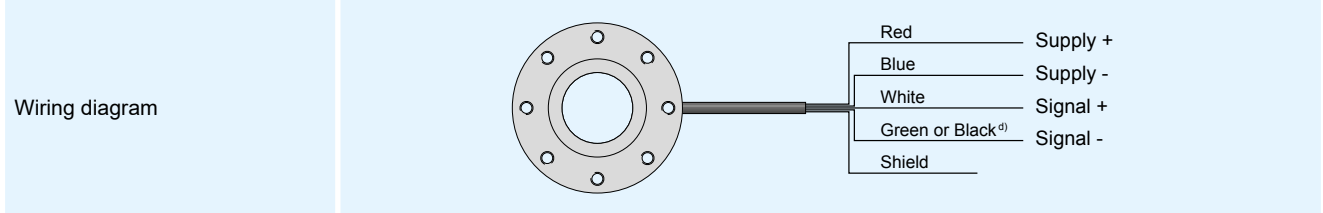

a) Maximum axial load (AL) and maximum lateral load (LL) are explained here after

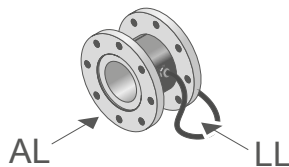

b) Each transducer is delivered with an acceptance test report, on which its specific sensibility is reported

c) Suitable strain gauge amplifier options: LMU209, LMU212, AN 1500 M

d) On the RT 112 & RT 113 the wire for "Signal -" is black

DIMENSIONS RT 112 - 117

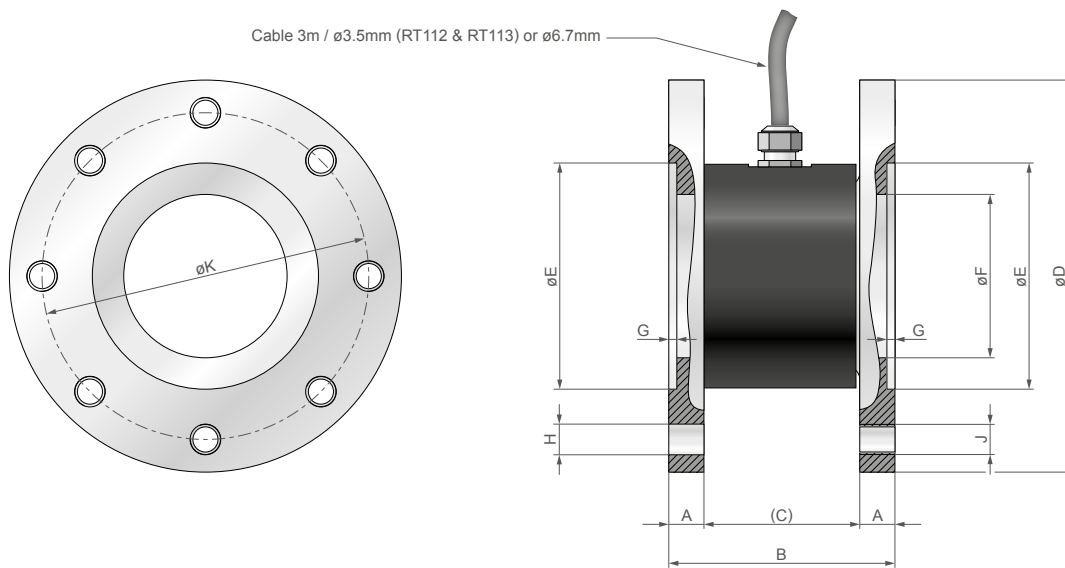

NOTE: All values are in metric units. Dimensions are in millimeters

MODEL	A	B	C	øD	øE H7	øF	G	H (8x)	J (8x)	øK	Fixing screws	Screwing torque
RT 112	10	65	45	106	60	40	3.2	ø10.5	ø10.5	86	M10 (8x) <sup>a)</sup>	79 N·m
RT 113									M12	130	M12 (8x) <sup>a)</sup>	137 N·m
RT 114	14	90	62	156	90	65		ø12.2	M12	130	M12 (8x) <sup>a)</sup>	137 N·m
RT 115							ø14.5	M14	155.5	M14 (8x) <sup>a)</sup>	218 N·m	
RT 116	20	120	80	182	110	78	4	ø14.5	M14	155.5	M14 (8x) <sup>a)</sup>	218 N·m
RT 117	22	140	96	228		100	4.2	ø18.5	M18	185	M18 (8x) <sup>a)</sup>	469 N·m

a) Property class of the screws, according to the standard ISO 898-1 : Property Classes 10.9

DIMENSIONS RT 118 - 120

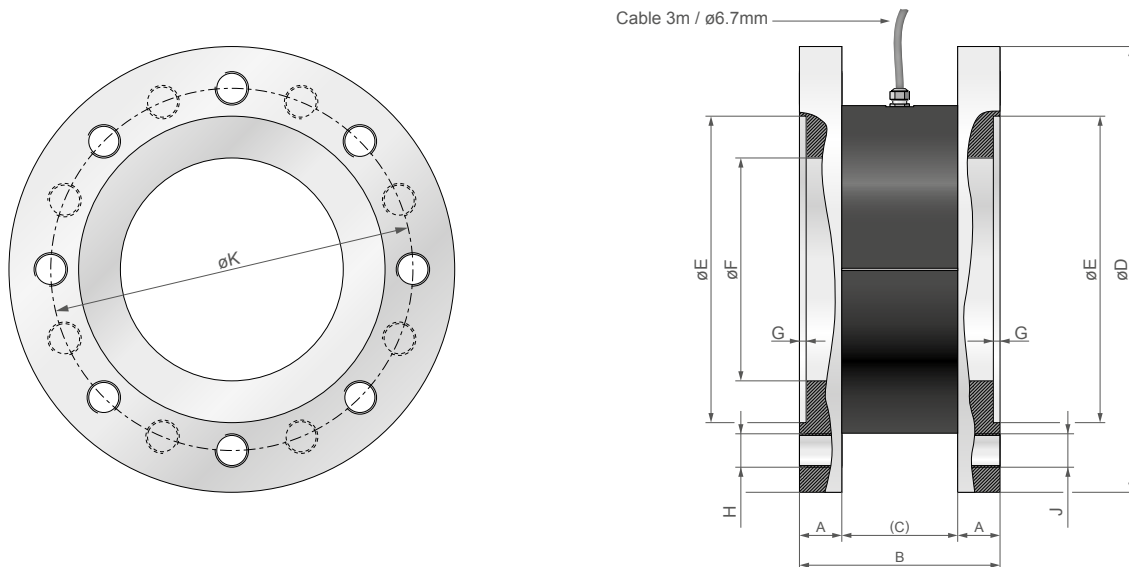

NOTE: All values are in metric units. Dimensions are in millimeters

MODEL	A	B	C	øD	øE H7	øF	G	H	øK ±0.02	Fixing screws	Screwing torque
RT 118	38	180	104	400	275	222	6	M30 (8x)	325	M30 (8x) <sup>a)</sup>	2662 N·m
RT 119										M30 (16x) <sup>a)</sup>	
RT 120										M30 (16x) <sup>a)</sup>	

a) Property class of the screws, according to the standard ISO 898-1 : Property Classes 12.9

SYSTEM OPTIONS AND ACCESSORIES

LMU 209 - LOAD MONITORING UNIT



Fig. 2: LMU 209 | Load Monitoring Unit (Polycarbonate housing for DIN-rail mount)

For dynamic measurement, MAGTROL recommends the LMU 209 Load Monitoring Unit, which offers a passband up to 3kHz, which allows the measurement of high dynamic torque peak.

The LMU 209 is a versatile strain gauge amplifier, designed for signal conditioning and interfacing low level signals to programmable logic

controllers (PLCs) or any control unit with analog inputs. The LMU 209 features both voltage and current-type outputs. Due to its integrated DIP-switches, the amplifier can be easily configured to the desired input ranges.

This modularized amplifier is available either in polycarbonate housing for DIN-rails mount or in aluminum housing for harsh applications. All wires are connected to screw terminals.

PSD - PORTABLE SENSOR DISPLAY



Fig. 3: PSD | Portable Sensor Display

The PSD Portable Sensor Display from Magtrol is a very compact, light and easy to use device. This amplifier can process sensor strain gauge signals  $\pm 0.3 \dots 5 \text{ mV/V}$ . High measuring accuracy, paired with fast measuring rates allow an internal resolution of 22 bits at 2mV/V. It also stores the adjustment data, sensor designation and physical

unit. Functions, such as TARE, recall of min.-max. value,... are available during the measurement.

The device is powered by 3 AA batteries or via its USB Mini-B port. In order to increase its duration of use, the PSD integrates an automatic standby mode which is activated when the device is not used.

The PSD can be used with many sensors such as force sensors, load cells, torque sensors, anchor sensors or any other type of strain gauge transducers.

AN SERIES - LOAD MONITOR DISPLAY WITH INTEGRATED SIGNAL CONDITIONER



Fig. 4: AN Series | Load Monitor Display with integrated signal conditioner

The AN Series Load Monitor is designed to process and display signals coming from various types of transducers (weight, load, pressure, torque, etc.) that use standard strain-gauge bridges.

The basic instrument is a soldered assembly composed of a main board, a tri-color programmable display and a power circuit. Standard features include the reading of the input variable as well as remote hold, reading and memorization of max and min values (peak / valley), tare and reset function.

Further information on accessories are available in their specific data sheets. Please, visit our website: [www.magtrol.com](http://www.magtrol.com)

ORDERING INFORMATION

ORDERING NUMBER P/N 125 - - - - - 000 - 11X

112, 113, ..., 120 : Model number

Example: RT 115 Reaction Torque Sensor would be ordered as: P/N 125 - 115 - 000 - 11X.