

HRL SERIES

ANCHOR LOAD CELL

FEATURES

- Monitors anchor forces and other force measurements
- Range: 600 ... 3000kN
- Admissible overload: 120 % of the nominal load
- Maximum load: 250 % of the nominal load
- Suitable for heavy-duty use on construction sites
- Easy to assemble
- Protection class: IP66
- Special designs available upon request
- Option: Surge Protection



Fig. 1: HRL-4 | 600kN with LEMO connector and its screw-on cap

DESCRIPTION

HRL Series Anchor Load Cells consist of a high quality stainless steel. This compact load cell is designed specifically for heavy duty use on construction sites, with load cells that are available in the range 600...3000 kN. Special designs are available upon request.

The attached shielded cable includes a water-proof connector with cap. Version without connector are available as an option. Cable lengths are customisable according to the installation requirements; for further information please contact us.

The data collected from the strain gauge is proportional to the applied force. The signal is transmitted to the monitoring unit for amplification.

APPLICATION

The Magtrol HRL Series Anchor Load Cells can be used to monitor anchor forces in classical and pre-stressed structures on sites (civil engineering, tunnels...) as well as a range of other static or dynamic measurements, in harsh, tropical, off-shore, marine and harbour environments.



Fig. 2: HRL-4-1000 (4 strands) mounted on cable anchor

SYSTEM CONFIGURATION

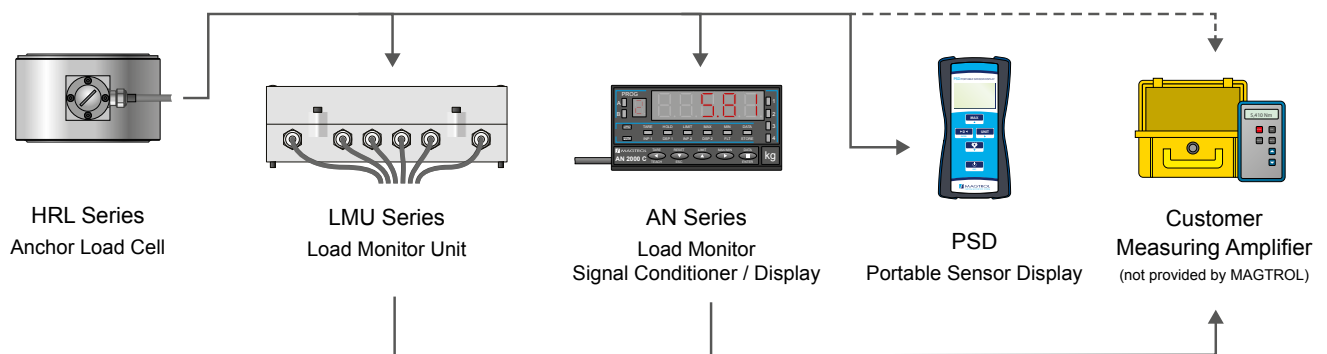

TECHNICAL DATA

MODEL	HRL -4 -1000	HRL -7 -1500	HRL -12 -2000	HRL -19 -3000
-------	--------------	--------------	---------------	---------------

MECHANICAL CHARACTERISTICS

Number of strands	4	7	12	19
Nominal Load (NL)	600kN	1000kN	2000kN	3000kN
Admissible Overload (% of NL)	120 %			
Overload at Rupture (% of NL)	250 %			
Accuracy Class	1 % (of NL) ^{a)}			

ELECTRICAL CHARACTERISTICS

Nominal Sensitivity	1.98mV/V ± 1 %	2.2mV/V ± 1 %	1.8mV/V ± 1 %	1.91mV/V ± 1 %
Input Resistance	700 ... 1100Ω			
Output Resistance	700Ω			
Nominal Supply Voltage of Strain Bridge	5 ... 10V			
Combined Error (Non-linearity + Hysteresis)	1 %			

ENVIRONMENT

Reference Temperature	+23 °C			
Operating Temperature	-30 °C ... +70 °C			
Temperature Influence: On Zero	≤ ± 0.01 % / K			
Temperature Influence: On Sensitivity	≤ ± 0.01 % / K			
Protection Class	IP66			
Option: Surge Protection	up to 20kA (8/20 μs)			

ELECTRICAL CONNECTION

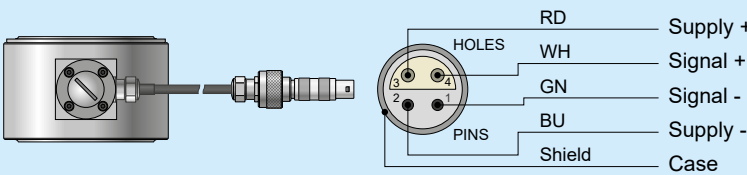
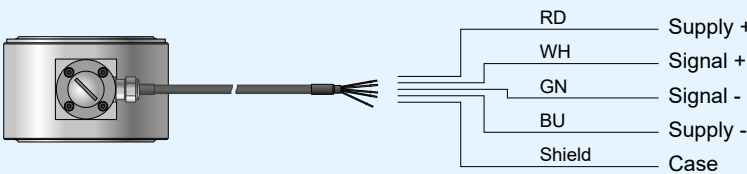
Connectic	Integrated cable with LEMO connector (several cable lengths are available on request)			
Wiring diagram (with standard connector LEMO)				
Wiring diagram (without connector)				

a) Accuracy depends on the environment, the assembly and the quality of the supports.

DIMENSIONS

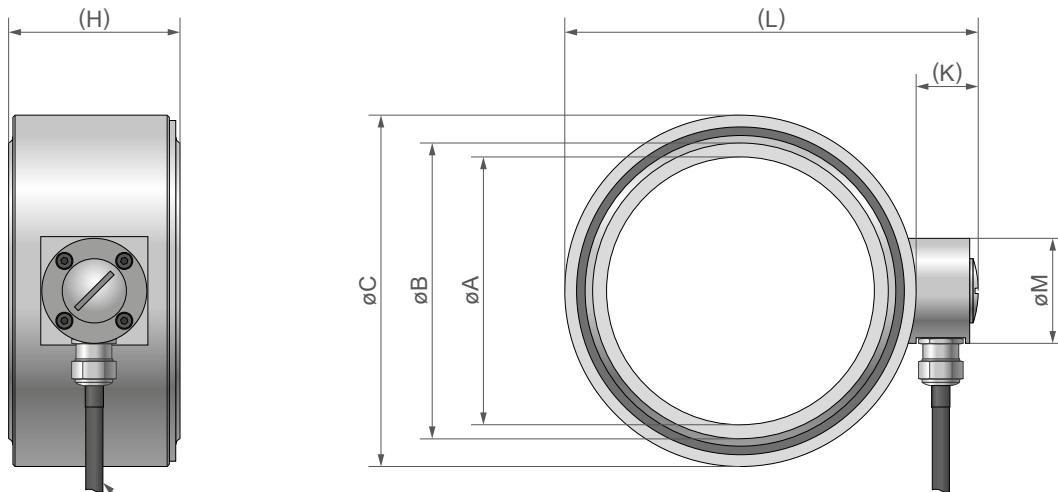

All lengths of cable available on request

NOTE: All dimensions are in metric units.

MODEL	øA	øB	øC	H	K	L	M	Weight	
HRL-4-1000	100	111	136	80	28	164	ø49	~4.5 kg	
HRL-7S-1500	125	138	164	80	29	193		~5.8 kg	
HRL-7-1500				100				~6.3 kg	
HRL-12S-2000	160	181	206	80		235		271	~8.5 kg
HRL-12-2000				128					~9.5 kg
HRL-19-3000	190	216	242	130					~15.0 kg

NOTE: 3D STEP files of most of our products are available on our website: www.magtrol.com; other files are available on request.

ASSEMBLY

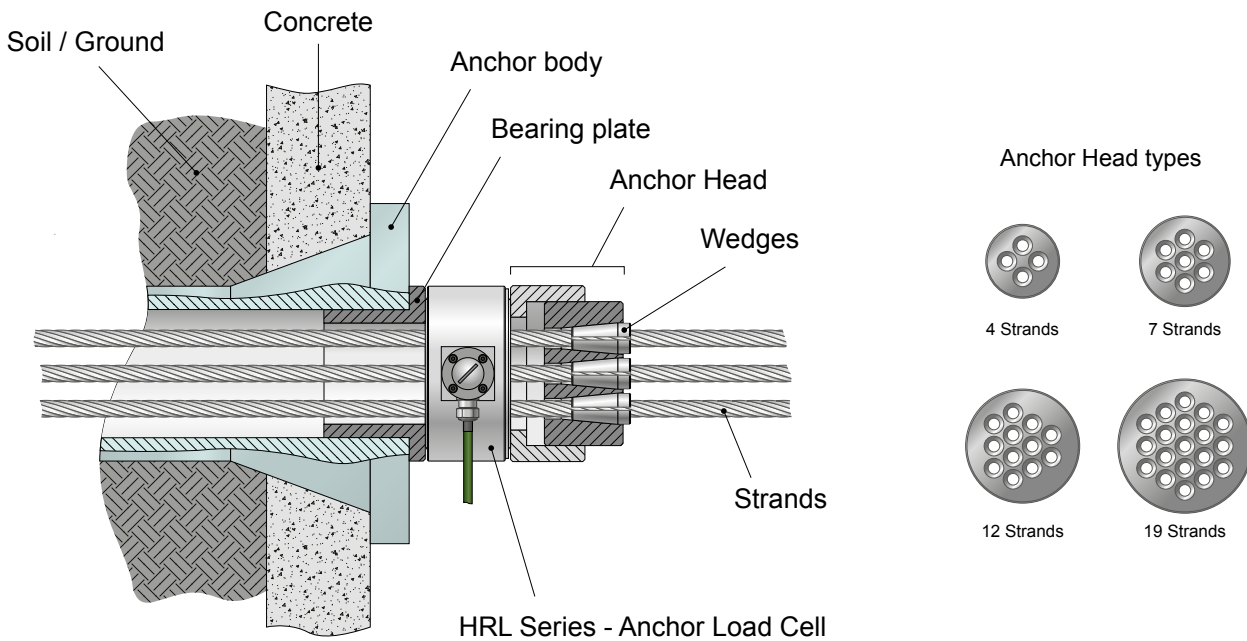

SYSTEM OPTIONS AND ACCESSORIES

PSD - PORTABLE SENSOR DISPLAY



Fig. 3: PSD | Portable Sensor Display

The PSD Portable Sensor Display from Magtrol is a very compact, light and easy to use device. This amplifier can process sensor strain gauge signals $\pm 0.3 \dots 5 \text{ mV/V}$. High measuring accuracy, paired with fast measuring rates allow an internal resolution of 22bits at 2mV/V. It also stores the adjustment data, sensor designation

and physical unit. Functions, such as TARE, recall of min.-max. value,... are available during the measurement.

The device is powered by 3 AA batteries or via its USB Mini-B port. In order to increase its duration of use, the PSD integrates an automatic standby mode which is activated when the device is not used.

The PSD can be used with many sensors such as force sensors, load cells, torque sensors, anchor sensors or any other type of strain gauge transducers.

LMU SERIES - LOAD MONITORING UNIT



Fig. 4: LMU 217 | Load Monitoring Unit

The Magtrol Load Monitoring Unit is specially designed for strain gauge transducer applications. Specifically developed for use with Magtrol load measuring pins and load-force-weight sensors, the LMU Series provides excitation current and amplifies the output signal of full-bridge strain gauges. Configurable relays and analog outputs are also available.

Its IP 65 aluminum housing allows the system to be used in harsh environments.

AN SERIES - LOAD MONITOR DISPLAY WITH INTEGRATED SIGNAL CONDITIONER



Fig. 5: AN Series | Load Monitor Display with integrated signal conditioner

The AN Series Load Monitor is designed to process and display signals coming from various types of transducers (weight, load, pressure, torque, etc.) that use standard strain-gauge bridges.

The basic instrument is a soldered assembly composed of a main board, a tri-color programmable display and a power circuit. Standard features include the reading of the input variable as well as remote hold, reading and memorization of max and min values (peak / valley), tare and reset function.

Further information on accessories are available in their specific data sheets. Please, visit our website: www.magtrol.com

ORDERING INFORMATION

ORDERING NUMBER	HRL -	-	-	-	-	-	-	-
4, 7, 12, 19 : Number of strands								
Blank : Higher version S : Short version (see dimensions)								
1000, 1500, 2000, 3000 : Model (see specifications)								
A : With connector B : Without connector C : Lightning and surge protection with connector D : Lightning and surge protection without connector								
Length of cable (in meter) : 01, 02, 03, ..., 10, ...								

Example: HRL Load Cell, 7 strands, with nominal load 1000kN, short version, with lightning protection, with connector and 8m cable would be ordered as follows: **HRL - 7S - 1500 - C08**.

HRL Load Cell, 12 strands, with nominal load 2 000 kN, higher version, without lightning protection, without connector and 14 m cable would be ordered as follows: **HRL - 12-2000 - B14**.