

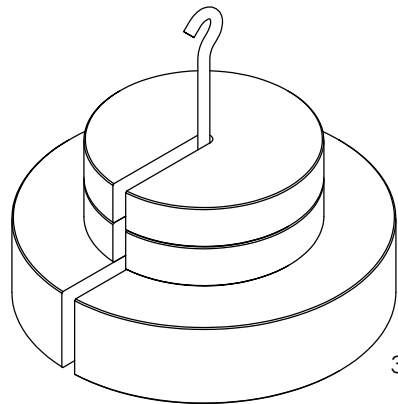

REVISIONS				
LETTER	DATE	BY	ECN	DESCRIPTION

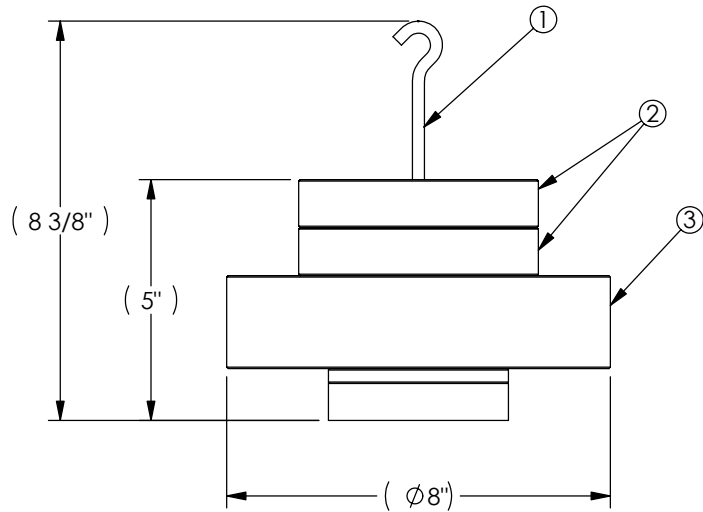

3 DIMENSIONAL VIEW
SCALE 1 : 4

ITEM NO.	PART NUMBER	DESCRIPTION	QTY.
3	51W019	CAL WEIGHT, SLOTTED, 10 kg	1
2	51W017	CAL WEIGHT, SLOTTED, 2 kg	2
1	51W016	CAL WEIGHT, HANGER, 1 kg	1

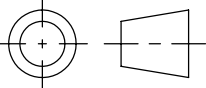
MATERIAL: (CAST IRON)	DESIGN	-	-	 MAGTROL INC. 70 GARDENVILLE PKWY, W. BUFFALO, NEW YORK 14224-1322	
	DRAWN	JEF	01/18/07		
FINISH: -	CHECKED	-	-	TITLE WT-825M, CAL WEIGHT KIT, 15 kg	
THIRD ANGLE PROJECTION 	UNLESS OTHERWISE SPECIFIED: DIMENSIONS ARE IN INCHES, DIAMETERS CONCENTRIC: .003 TIR, FACES PERPENDICULAR: .003 INTERPRETATION PER ASME Y14.5M-1994 REMOVE ALL BURRS AND BREAK SHARP EDGES .005/.010 X 45°, ALL INSIDE CORNERS TO BE .02 R MAX. TOLERANCES: .XX ± .01 FRAC. ± 1/64" .XXX ± .005 ANG. ± 1° SURFACE FINISH 125 RMS MAX. U.O.S.			USED ON: - SIMILAR TO: - DWG. NO. <div style="font-size: 24pt; font-weight: bold;">51W022</div>	
THIS DRAWING AND SPECIFICATION CONTAINS PROPRIETARY INFORMATION TO MAGTROL INC. ANY DISCLOSURE OR REPRODUCTION OF THIS DOCUMENT WITHOUT WRITTEN AUTHORIZATION FROM MAGTROL INC. IS EXPRESSLY PROHIBITED	SIZE <div style="font-size: 24pt; font-weight: bold;">A</div>			SCALE <div style="font-size: 24pt; font-weight: bold;">1:4</div>	SHEET # <div style="font-size: 24pt; font-weight: bold;">1 OF 1</div>