

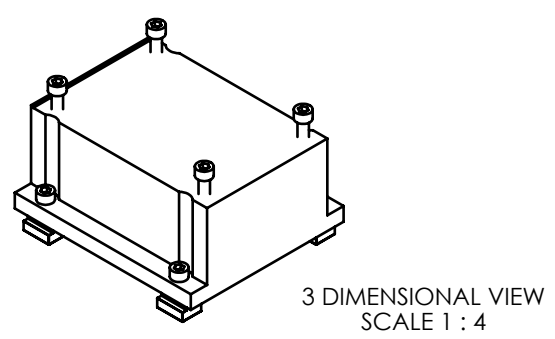

ITEM NO.	PART NUMBER	DESCRIPTION	QTY
1	204352	RISER BLOCK, RTM-2-120	1
2	504215	T-NUT, M6x1.0 X 8mm SLOT WIDTH	4
3	505677	SHCS M6x1 X 20mm 18-8 SS	8

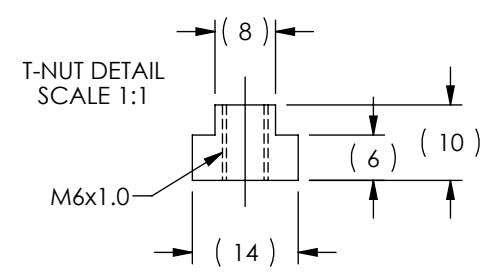
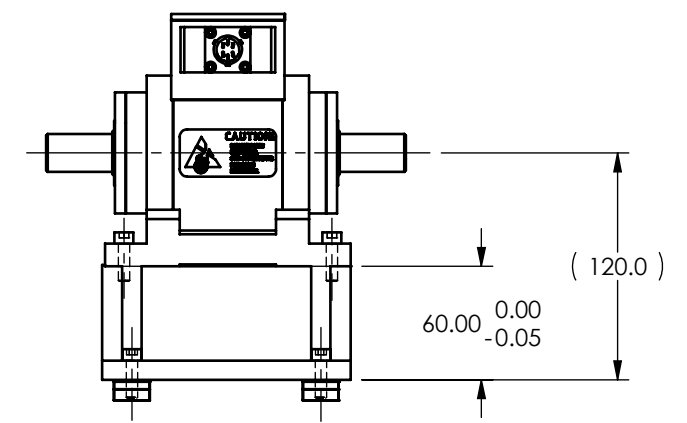
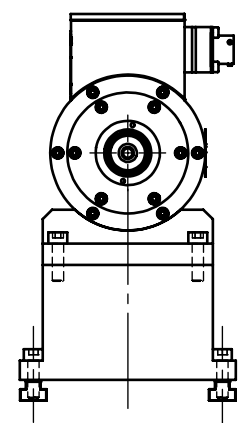
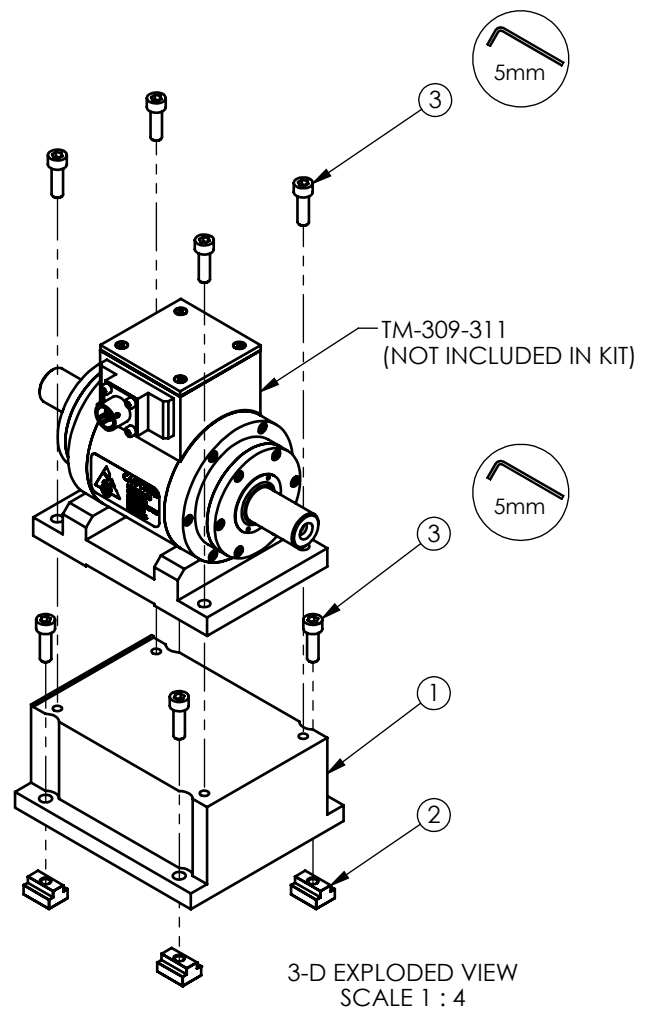
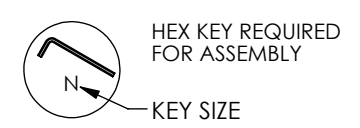

STOCK CODE: 005674

- NOTES:
- CENTER HEIGHT IS EQUIVALENT TO AHB-12 & AHB-24
 - T-NUT SPACING IS PT-SERIES COMPATIBLE

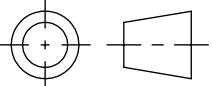

MATERIAL: -	DESIGN	JEF	01/13/06	 MAGTROL INC. 70 GARDENVILLE PKWY, W. BUFFALO, NEW YORK 14224-1322
	DRAWN	JEF	01/16/06	
FINISH: -	CHECKED	DTW	01/20/06	TITLE: RTM-2-120 RISER KIT
	THIRD ANGLE PROJECTION 			UNLESS OTHERWISE SPECIFIED: DIMENSIONS ARE IN MILLIMETERS, DIAMETERS CONCENTRIC: 0.08 TIR, FACES PERPENDICULAR: 0.08 INTERPRETATION PER ASME Y14.5M-1994 REMOVE ALL BURRS AND BREAK SHARP EDGES 0.13/0.25 X 45°, ALL INSIDE CORNERS TO BE R 0.5 MAX. TOLERANCES: X ±0.4 X.XX ±0.13 X.X ±0.25 ANG. ±1° SURFACE FINISH 3.2 μm MAX. U.O.S.
THIS DRAWING AND SPECIFICATION CONTAINS PROPRIETARY INFORMATION TO MAGTROL INC. ANY DISCLOSURE OR REPRODUCTION OF THIS DOCUMENT WITHOUT WRITTEN AUTHORIZATION FROM MAGTROL INC. IS EXPRESSLY PROHIBITED				USED ON: - SIMILAR TO: - DRAWING NUMBER: RTM-2-120
			SIZE B	SCALE 1:4
			SHEET # 2 OF 2	REV B