

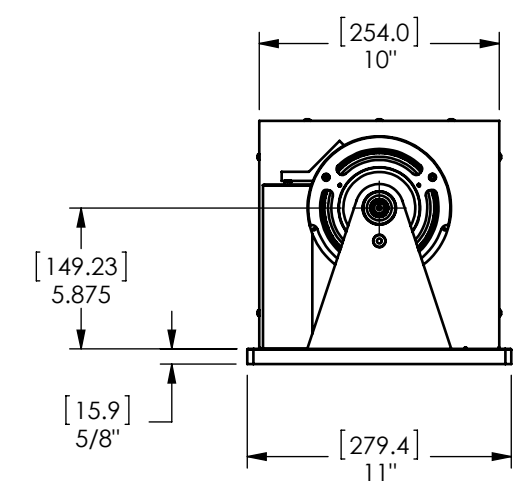

MODEL	TORQUE MEASURE UNIT CODE (-XXX)	STOCK CODE	MAXIMUM TORQUE RANGE	DRAG TORQUE DE-ENERGIZED AT 1000 RPM	NOMINAL INPUT INERTIA		MAXIMUM POWER		MAXIMUM SPEED (RPM)	COOLING METHOD
					(lb•ft•s <sup>2</sup> )	(kg•m <sup>2</sup> )	5-MINUTE (Watts)	CONTINUOUS (Watts)		
HD-705-XXX-0100	5N	006716	6.20 N m	0.023 N m	1.10 x 10 <sup>-3</sup>	1.49 x 10 <sup>-3</sup>	1,400	300	25,000	CONVECTION
	5NA	006717								
	6N	005938	55.0 lb in	0.2 lb in						
	6NA	005941								
	7N	005939	62.0 kg cm	0.24 kg cm						
	7NA	005942								
	8N	005940	6.20 N m	0.023 N m						
	8NA	005943								

**SOLID MODEL AVAILABLE**

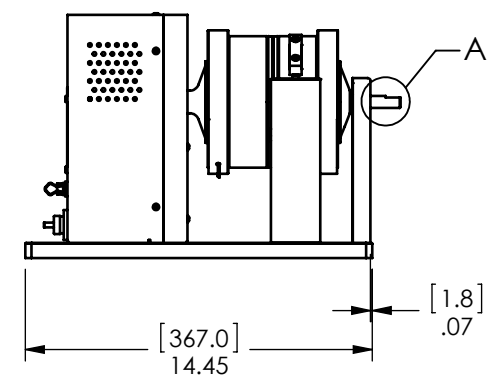
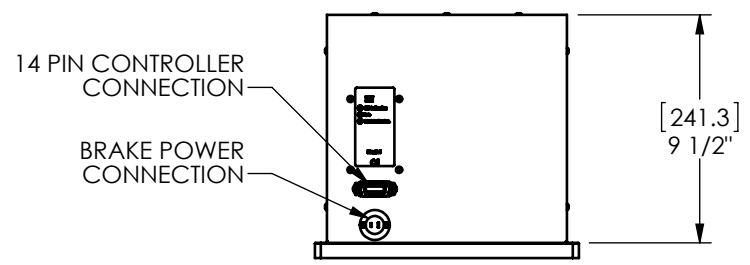
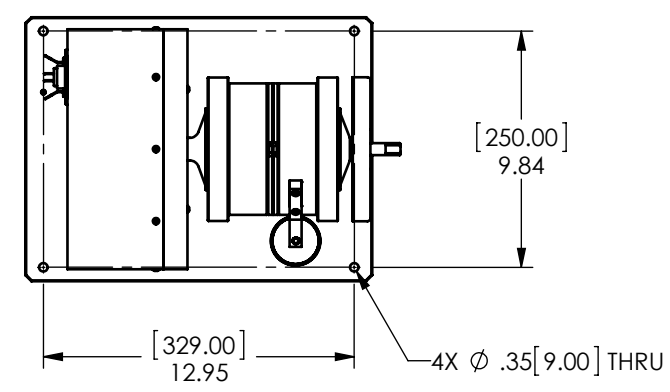
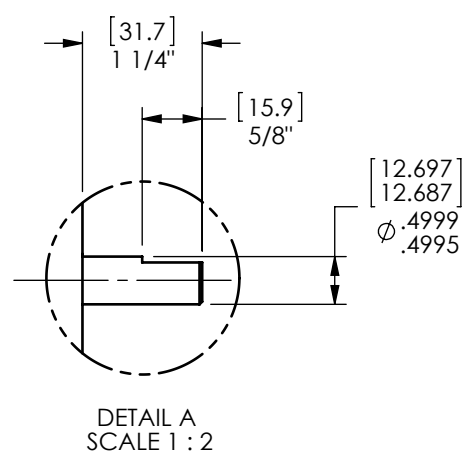
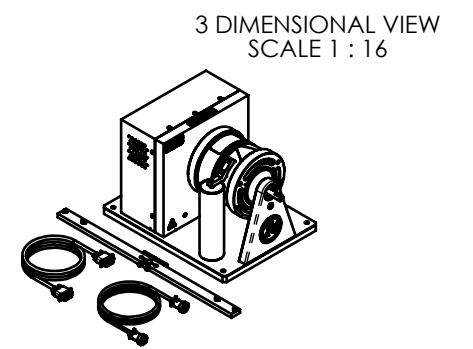

**INSTALLATION DRAWING**

MATERIAL:	DESIGN	-	-	 <b>MAGTROL INC.</b> 70 GARDENVILLE PKWY, W. BUFFALO, NEW YORK 14224-1322
FINISH:	DRAWN	JEF	02/28/11	
THIRD ANGLE PROJECTION	CHECKED	-	-	TITLE: HD-705-0100 DYNAMOMETER
THIS DRAWING AND SPECIFICATION CONTAINS PROPRIETARY INFORMATION TO MAGTROL INC. ANY DISCLOSURE OR REPRODUCTION OF THIS DOCUMENT WITHOUT WRITTEN AUTHORIZATION FROM MAGTROL INC. IS EXPRESSLY PROHIBITED	UNLESS OTHERWISE SPECIFIED: DIMENSIONS ARE IN INCHES DIAMETERS CONCENTRIC: .003 TIR FACES PERPENDICULAR: .003 INTERPRETATION PER ASME Y14.5M-1994 REMOVE ALL BURRS AND BREAK SHARP EDGES .005/.010 X 45° INSIDE CORNERS TO BE R .02 MAX TOLERANCES: .XX ± .01 X/Y ± 1/64" .XXX ± .005 ANG ± 1° SURFACE FINISH 125 RMS MAX			USED ON: SIMILAR TO:
	DWG NO: <div style="display: flex; justify-content: space-between;"> <span>HD-705-0100</span> <span>REV A</span> </div>			SIZE B
NOTE: DIMENSIONS IN [ ] ARE MILLIMETERS.		SCALE 1:8		