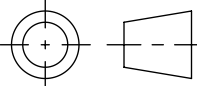

NOTE: DIMENSIONS IN [ ] ARE MILLIMETERS

MATERIAL: -	DESIGN	AJC	07/29/08	 <b>MAGTROL INC.</b> 70 GARDENVILLE PKWY, W. BUFFALO, NEW YORK 14224-1322
	DRAWN	AJC	07/29/08	
FINISH: -	CHECKED	-	-	TITLE <b>FIXED MOTOR FIXTURE, 700                  SERIES, 006487</b>
THIRD ANGLE PROJECTION 	UNLESS OTHERWISE SPECIFIED: DIMENSIONS ARE IN INCHES, DIAMETERS CONCENTRIC: .003 TIR, FACES PERPENDICULAR: .003 INTERPRETATION PER ASME Y14.5M-1994 REMOVE ALL BURRS AND BREAK SHARP EDGES .005/.010 X 45°, ALL INSIDE CORNERS TO BE .02 R MAX. TOLERANCES: .XX ± .01      FRAC. ± 1/64" .XXX ± .005    ANG. ± 1° SURFACE FINISH 125 RMS MAX. U.O.S.			
THIS DRAWING AND SPECIFICATION CONTAINS PROPRIETARY INFORMATION TO MAGTROL INC. ANY DISCLOSURE OR REPRODUCTION OF THIS DOCUMENT WITHOUT WRITTEN AUTHORIZATION FROM MAGTROL INC. IS EXPRESSLY PROHIBITED				USED ON: - SIMILAR TO: 006486 DWG. NO. <b>FMF-700-TAB</b>
SIZE <b>B</b>		SCALE <b>1:8</b>	SHEET # <b>2 OF 2</b>	REV -