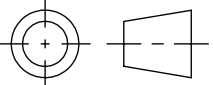

3 DIMENSIONAL VIEW
SCALE 1:4

INSTALLATION DRAWING

MATERIAL: -	DESIGN	DTW	12/12/12	 MAGTROL INC. 70 GARDENVILLE PKWY, W. BUFFALO, NEW YORK 14224-1322
	DRAWN	AJC	01/03/13	
FINISH: -	CHECKED	DTW	01/03/13	TITLE: FIXED MOTOR FIXTURE, 100/106/400 SERIES, 006946
	THIRD ANGLE PROJECTION 			
UNLESS OTHERWISE SPECIFIED: DIMENSIONS ARE IN MILLIMETERS DIAMETERS CONCENTRIC: .08 TIR FACES PERPENDICULAR: .08 INTERPRETATION PER ASME Y14.5M-1994 REMOVE ALL BURRS AND BREAK SHARP EDGES 0.13/0.25 X 45° INSIDE CORNERS TO BE R 0.5 MAX TOLERANCES: .X ± .25 X ± .4 .XX ± .13 X° ± 1° SURFACE FINISH 3.2 µm MAX				DWG NO: FMF-400-PT
THIS DRAWING AND SPECIFICATION CONTAINS PROPRIETARY INFORMATION TO MAGTROL INC. ANY DISCLOSURE OR REPRODUCTION OF THIS DOCUMENT WITHOUT WRITTEN AUTHORIZATION FROM MAGTROL INC. IS EXPRESSLY PROHIBITED				REV -
SIZE B		SCALE 1:4	SHEET #	