

EM-TEST 2.0

ENDURANCE MOTOR TESTING SOFTWARE

SPECIFIC FEATURES

- **Graphical User Interface:** User friendly tabbed pages for quick navigation.
- **Global Project :** Management Data and Setup of current project.
- **Lock / Unlock function:** Front Panel lock function prevents modification by an unauthorized operator.
- **Set-point table:** The set-point curve is defined in the data table. Sampling rate, voltage and Analog Output, Digital Output and Relay state are also defined in this table.
- **Endurance Testing:** Tests speed, torque, amps, watts input, watts output and open loop parameters. Capable of adjusting sampling rate by step and using step or ramp from one load point to the next.
- **DSP7000 / 6001 / 6000** Programmable Controller Support.
- **Micro Dyne** Motor Testing System Support.
- **Supports the optional Analog and Digital I/O Modules** on the DSP7000 Programmable Controller.
- Expanded power analyzer and power supply selections.
- Optional Analog and Digital I/O provides more device flexibility.
- **Temperature Security:** Over-Temperature control and Hysteresis Temperature function.
- **Three-Phase Power Meter Data Acquisition:** Obtain data on each individual phase and/or the sum used in the chosen parameters (amps, volts, input watts and power factor).
- **Spanning file function:** Auto-Incrementation of filename depending on cycle, hours, days or file size.
- **Graph and display during test:** Displays previous files during test in tabular or graphic view.
- **Recovery Function:** Recovers test if the computer crashes (Windows® problem, power off).

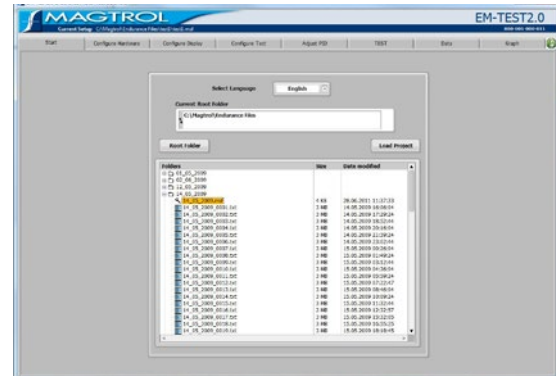

Fig.1 : Em-TEST 2.0 Project Management

DESCRIPTION

Magtrol's EM-TEST2.0 is an endurance motor testing software for PC (Windows®XP sp3/7/8) based data acquisition. Combined with a Magtrol DSP7000 High Speed Programmable Controller, EM-TEST2.0 works with any Magtrol dynamometer or in-line torque transducer to determine the performance characteristics of a motor under test. Up to 64 parameters are calculated and displayed utilizing EM-TEST2.0's unique testing and graphing capabilities.

An integral component of any Magtrol Endurance Motor Test System, EM-TEST2.0 performs curve testing in a manner best suited to the overall efficiency of the test rig. Written in LabVIEW™, EM-TEST2.0 has the flexibility to test a variety of motors in a multitude of configurations. The data generated from this user-friendly program can be stored, displayed and printed in tabular or graphical formats, and is easily imported into a spreadsheet.

Magtrol can also make custom modifications to the software to meet additional motor testing requirements.

APPLICATIONS

EM-TEST2.0 is designed for long-term motor test cycling. It is ideal for developmental applications. It has the ability to duplicate tests and run them automatically. This versatile program is extremely valuable to anyone involved in motor testing. EM-TEST2.0 can be used as stand alone software or in combination with M-TEST 7 Motor Testing Software.

STANDARD FEATURES

- **USB2.0:** Computer interface for DSP7000
- **IEEE-488:** Computer interface with National Instruments™ PCI-GPIB or USB-GPIB.
- **Multiple Language Support:** Switch to/from English, French, German at any point during the program. Additional language dictionaries can be created/edited by the user.
- **Automatic Load Defaults Option:** Downloads testing instrument parameters based on model number.
- **PID Adjustment Routines:** Helps adjust the system for step functions.
- **Rapid Graph Plotting:** Change both the X- and Y-axis to display additional test curves, without having to exit the graph.
- **Displays 63 Tested and Calculated Parameters:** Torque, speed and auxiliary input are displayed from the DSP6000/6001/7000 Controller; amps, volts and watts from an (optional) power analyzer. Calculated values including horsepower, efficiency, power factor, output watts and time can also be displayed. Optional analog and digital inputs can also be displayed.
- **Curve Fitting:** A curve fitting routine can be applied to most motor test curves. Raw data and curve fit data can also be displayed simultaneously.
- **Context Help:** Hover over any field or parameter with the mouse to display a context help box.

ANALOG INPUT MEASUREMENT

Up to 128 analog sensors can be read and monitored during a motor test. Heat rise curves on the bearings, windings and housing of a motor can be performed and air flow/exhaust efficiencies can be measured with an air tool or internal combustion engine.

EM-TEST2.0, with its complete dynamometer control, even allows for analog measurement while performing load simulation for duty cycle and life testing.

TEMPERATURE SENSOR MEASUREMENT

Up to 128 thermocouples can be read and monitored during a motor test. Heat rise curves on the bearings, windings and housing of a motor can be performed.

EM-TEST2.0, with its complete dynamometer control, allows for sensor measurement while performing load simulation for duty cycle and life testing.

Hysteresis function : If the temperature exceeds the high threshold, the test passes to Pause mode and a relay is disabled. When the temperature passes under the low threshold, the test passes to Run mode and a relay is enabled.

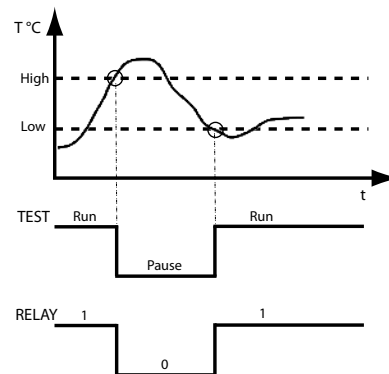

RELAY CONTROL

Up to 6 relays can be controlled during test. The state of each relay can be set for each step.

SYSTEM CONFIGURATION

A Magtrol Dynamometer provides motor loading with a Magtrol Programmable Controller acting as the interface between the PC running EM-TEST2.0 and the dynamometer. If the motors' electrical parameters are to be measured or used to determine load points, a Magtrol Power Analyzer is also required. The computer and electronic instrumentation interface through the National Instruments™ PCI-GPIB card and USB 2.0.

EM-TEST2.0 is equipped to work in conjunction with any of the following Magtrol motor testing instruments:

- Dynamometer Controller (DSP7000/6001/6000)
- Hysteresis, Eddy-Current or Powder Dynamometer (HD, HD5, WB, PB)
- Micro Dyne Motor Testing System
- In-Line Torque Transducer (TM, TF, TMB, TMHS)
- Power Analyzer (6530, 6510e, 6510, 6550, 5100, 5300, 5310, 5330)

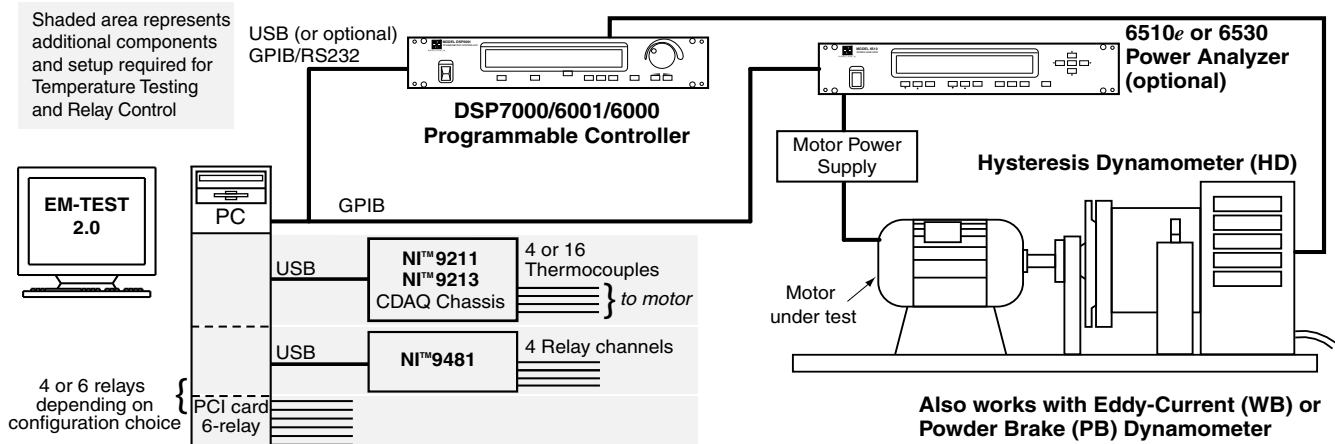

SYSTEM REQUIREMENTS

- Personal computer with Intel® Pentium® Core™2 Duo processor (or equivalent)
- Microsoft® Windows® XP sp3/7/8
- 2 GB of RAM
- 2 GB HDD of available hard drive space.
- VGA color monitor with minimum screen resolution of (1280 × 900)
- USB 2.0 available for DSP7000 (A GPIB or RS-232 interface is required for the DSP6000 and DSP6001)
- National Instruments™ PCI-GPIB card or USB-GPIB card (available from Magtrol)
- National Instruments™ NI 9211A NI 9213 hardware: Required only if temperature sensor input function will be used
- National Instruments™ NI 9481/PCI-652x hardware : required only if relay control function will be used.

SYSTEM OPTIONS AND ACCESSORIES

CATEGORY	DESCRIPTION	MODEL/PART #
TEMPERATURE TESTING HARDWARE	USB 4-Channel Isolated Input Module and USB Cable (1 m)	HW-TTEST-4
	USB 16-Channel Isolated Input Module and USB Cable (1 m)	HW-TTEST-16
RELAYS CARDS	PCI card 6 relays 150V AC/DC 2A max. 60 W	HW-RLTEST-PCI
	USB card 4 relays 30V DC 2A max. 60 W	HW-RLTEST-4
CONTROLLERS	High Speed Programmable Controller	DSP7000
MOTOR TEST EQUIPMENT	Hysteresis Dynamometers	HD series
	Eddy-Current Dynamometers	WB series
	Powder Brake Dynamometers	PB series
	In-Line Torque Transducers	TM/TMHS/TMB series
	Micro Dyne Motor Testing System	006542
POWER ANALYZERS	High Speed Single-Phase Power Analyzer	7510
	High Speed Three-Phase Power Analyzer	7530
CARDS	PCI-GPIB Interface Card	
	USB-GPIB Interface Card	
CABLES	GPIB Cable, 1 meter	88M047
	GPIB Cable, 2 meters	88M048
	Torque Transducer Connector Cable	ER 113/01

For information on the most current software release available, refer to Magtrol's Web site at <https://www.magtrol.com/product/em-test-2-0-endurance-motor-testing-software/>