

THE INFORMATION DISCLOSED HEREIN WAS ORIGINATED BY AND IS THE PROPERTY OF MAGTROL SA. MAGTROL SA RESERVES ALL PATENT PROPRIETARY, DESIGN, USE, SALE, MANUFACTURING AND REPRODUCTION RIGHTS THERETO.

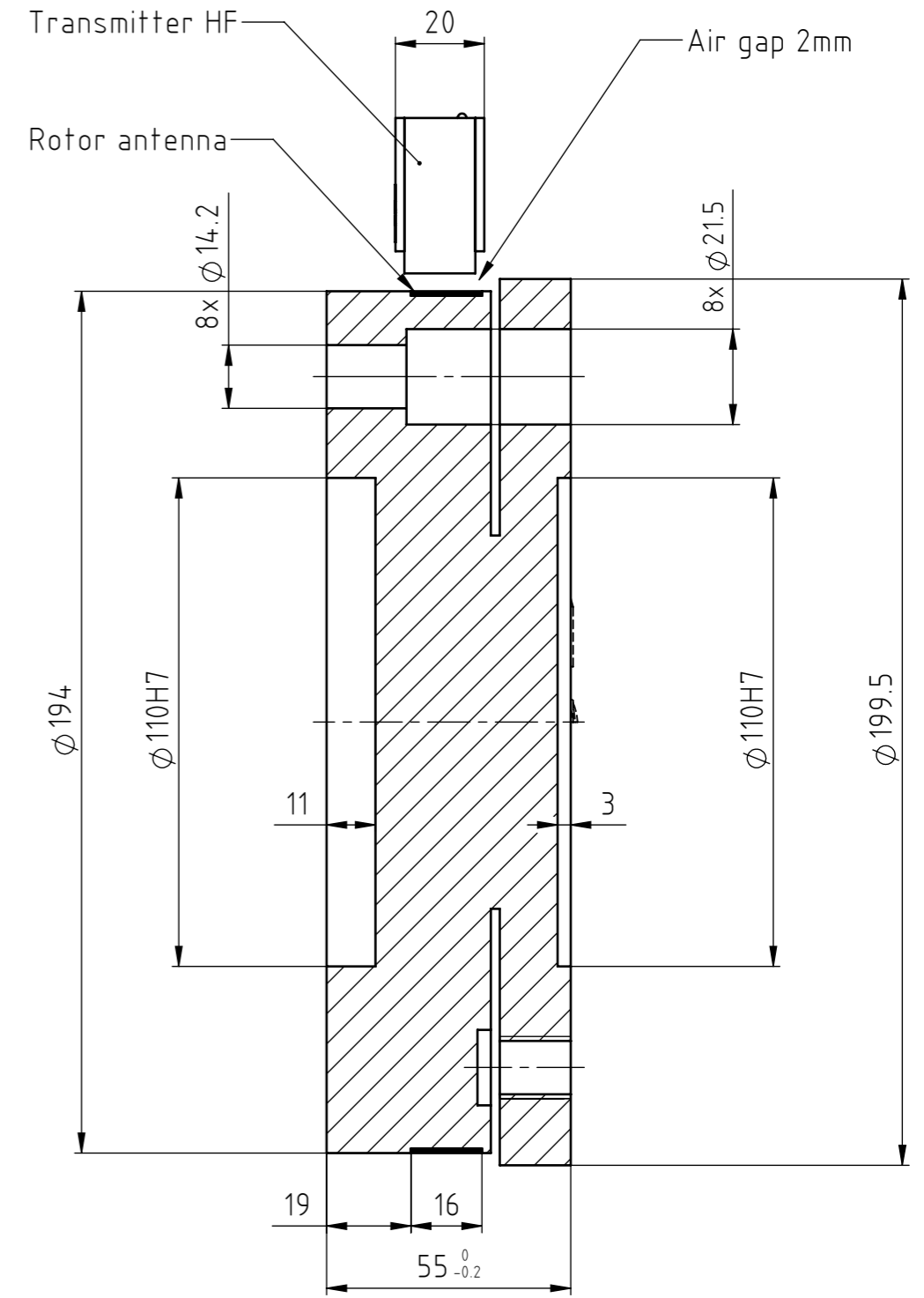

Error of linearity: 0.1%
 Maximum torque: 200% of nominal
 Maximum speed: 4'000 rpm
 Sensitivity: 1mV/V
 Strain gauge bridge: 700Ω
 Rated temperature range: +10°C to + 85°C
 Storage temperature range: -25°C to + 85°C
 Protection class: IP42

6															
5															
4															
3															
2															
1	14.04.08	08033	blot	blot	Changement de capteur de vitesse										
Rev.	Date	PM	Drawn	Appr.	Repl. by :										
					Repl. for:										
Tolerances: ±					mm to 50mm, ± mm over 50mm										
Material:					Scale 1:1.5										
Finish:					<table border="1"> <tr> <td>Drawn</td> <td>20.10.04</td> <td>B.Lottenbach</td> </tr> <tr> <td>Checked</td> <td></td> <td></td> </tr> <tr> <td>Approved</td> <td>20.10.04</td> <td>B.Lottenbach</td> </tr> </table>		Drawn	20.10.04	B.Lottenbach	Checked			Approved	20.10.04	B.Lottenbach
Drawn	20.10.04	B.Lottenbach													
Checked															
Approved	20.10.04	B.Lottenbach													
TF216 (5kNm) Torque Flange TF200					DRAWING N° 425-216-000V011										

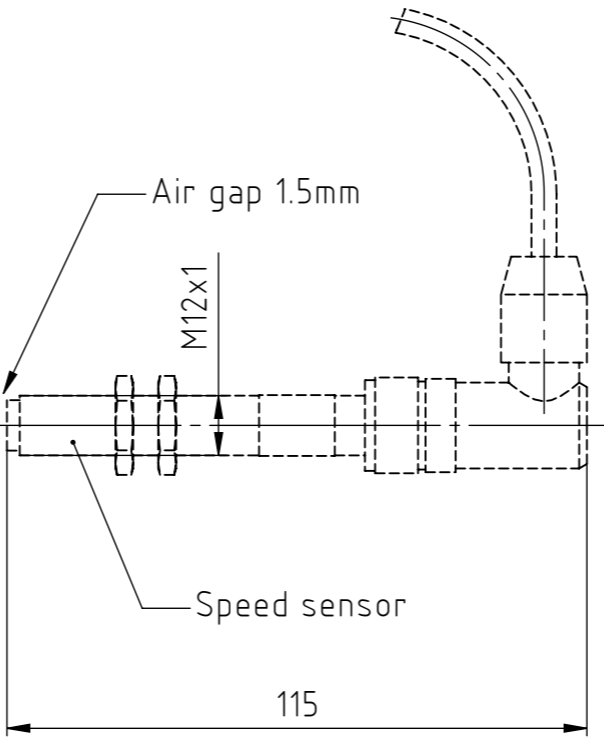
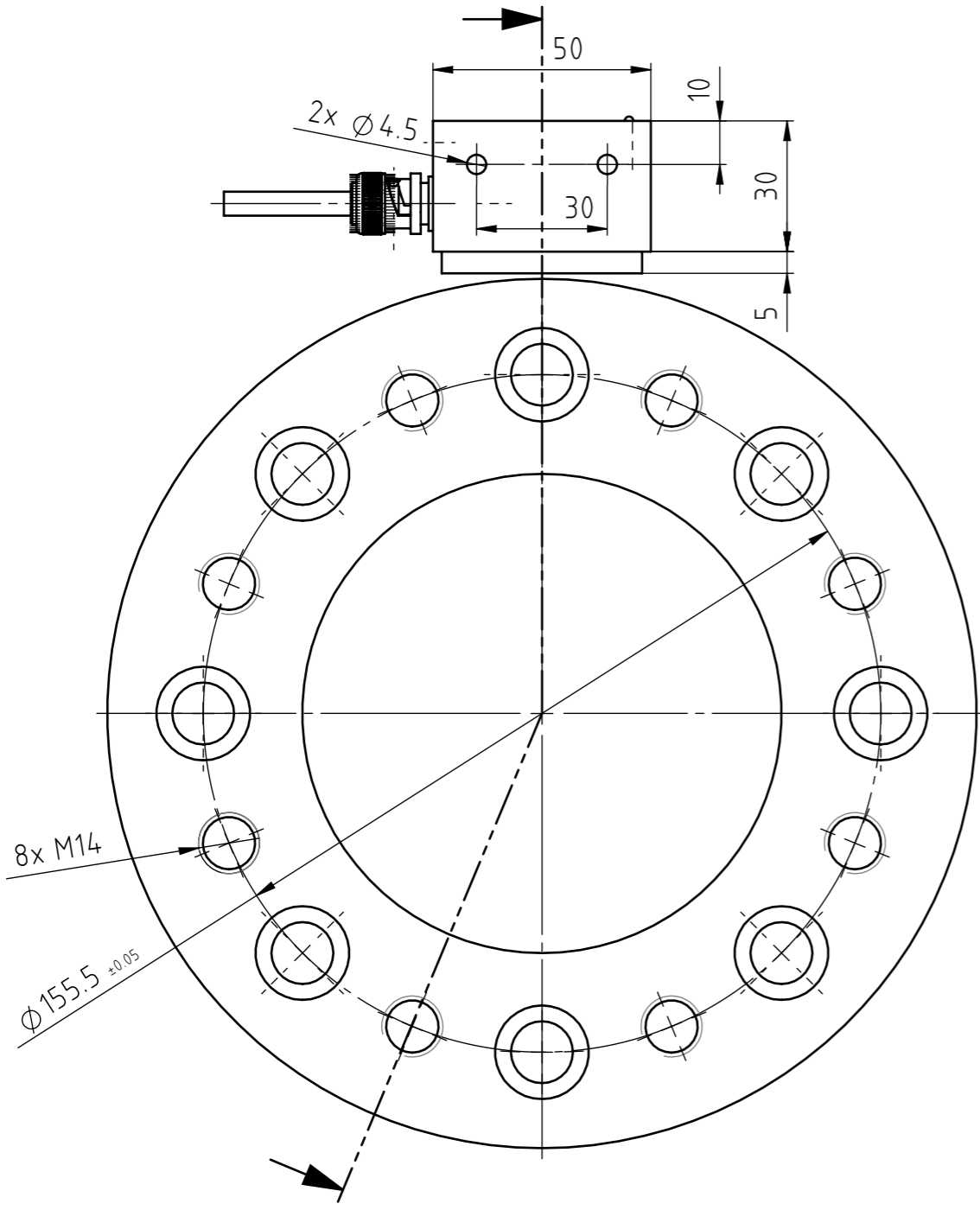