

THE INFORMATION DISCLOSED HEREIN WAS ORIGINATED BY AND IS THE PROPERTY OF MAGTROL SA. MAGTROL SA RESERVES ALL PATENT PROPRIETARY, DESIGN, USE, SALE, MANUFACTURING AND REPRODUCTION RIGHTS THERETO.

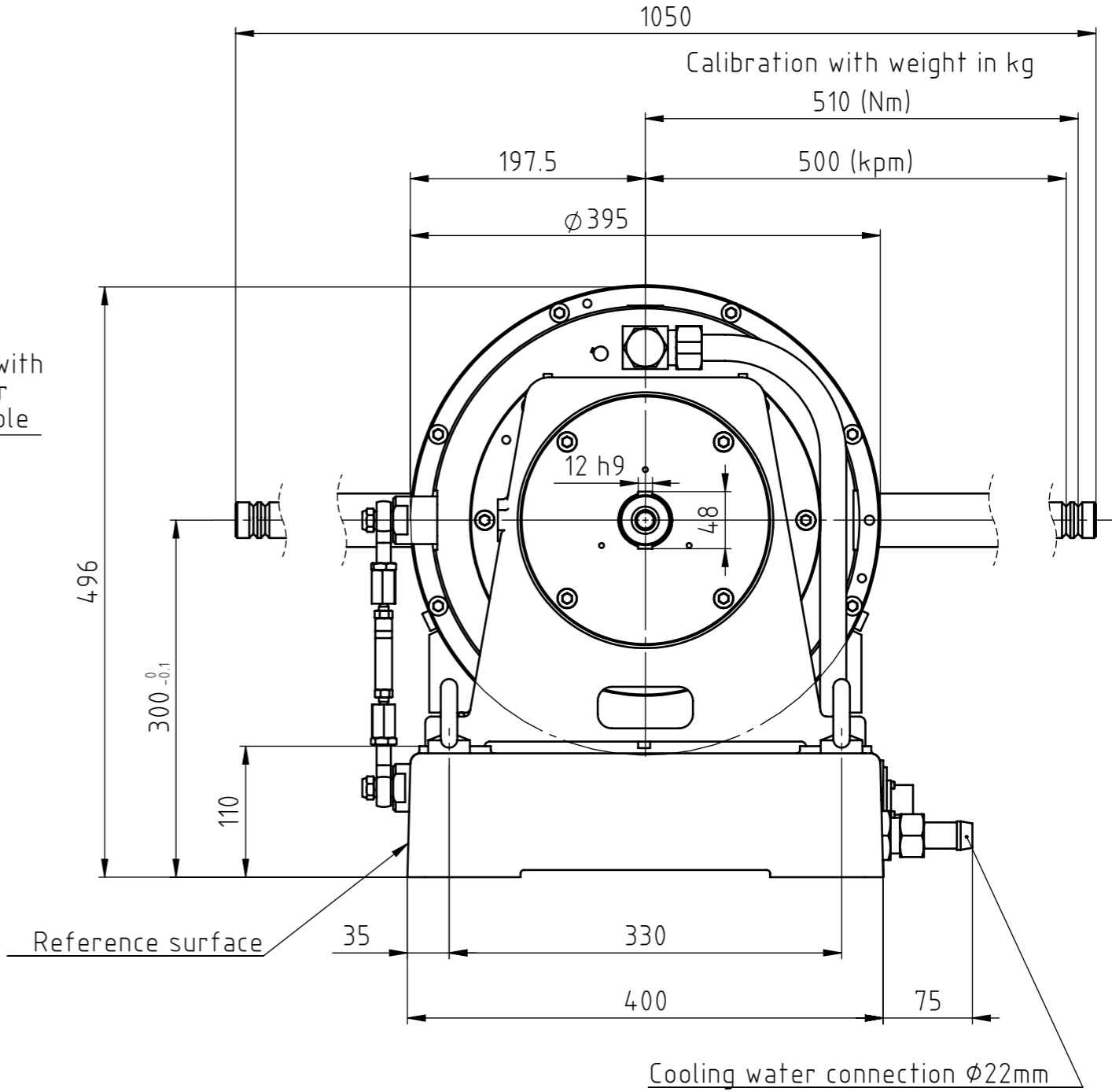

Type	A	B	C	D	E	G	H	J
1PB15-DG	544	370	150	48.5	-53	490	590	650
2PB15-DG	694	520	300	40.5	22	490	590	650
4PB15-DG	994	820	600	15.5	-3	840	940	1000

6									
5									
4									
3									
2									
1									
Rev.	Date	PM	Drawn	Appr.	Repl. by :				
					Repl. for:				
Tolerances: ± mm to 50mm, ± mm over 50mm									
Material:						Scale 1:5	Drawn	23.06.16	Ajoy
Finish:							Checked		
							Approved	23.06.16	Acot
Dynamometers 1-4PB15-DG						DRAWING N° 324-107-000V052			

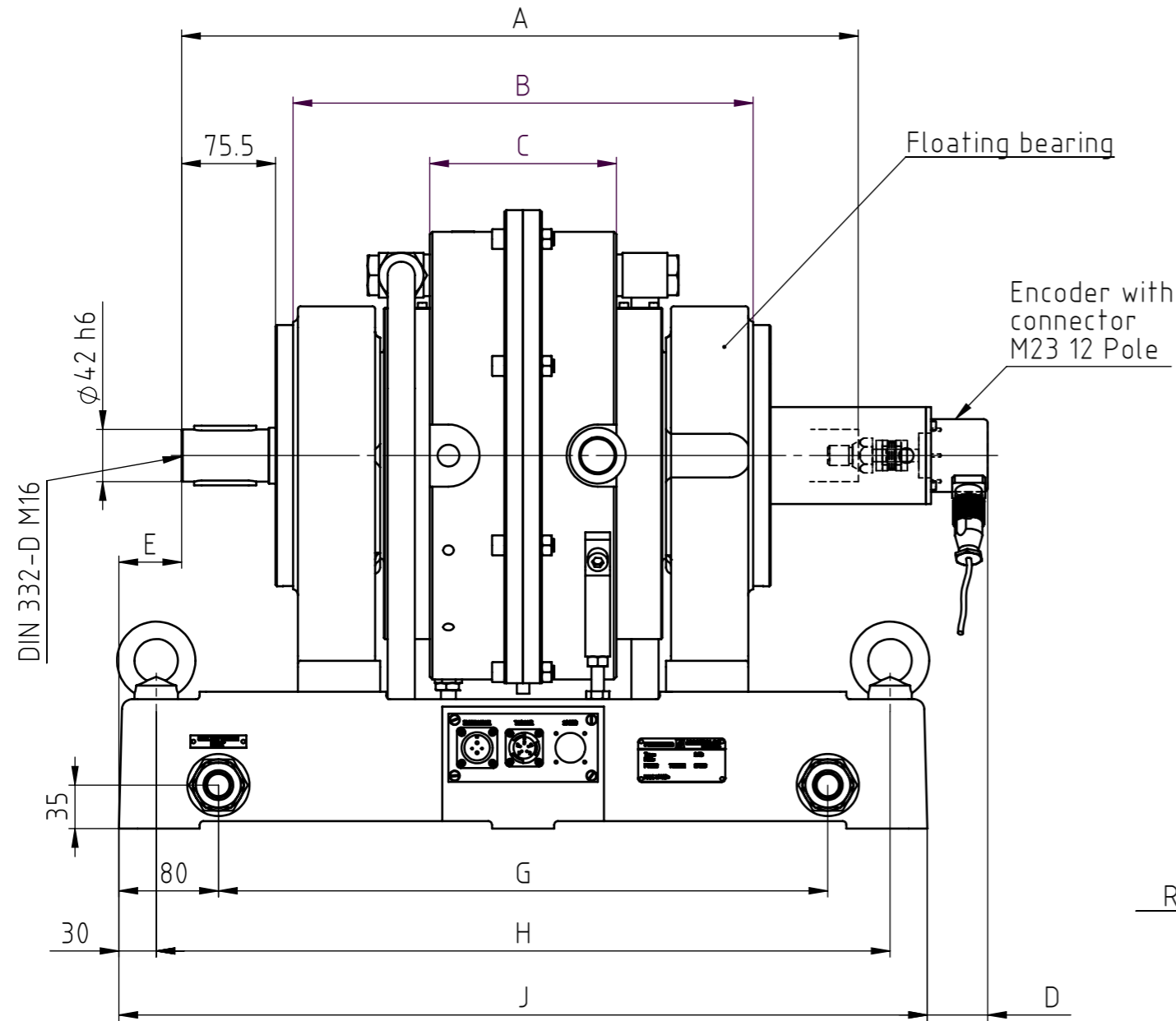