

THE INFORMATION DISCLOSED HEREIN WAS ORIGINATED BY AND IS THE PROPERTY OF MAGTROL SA. MAGTROL SA RESERVES ALL PATENT PROPRIETARY, DESIGN, USE, SALE, MANUFACTURING AND REPRODUCTION RIGHTS THERETO.

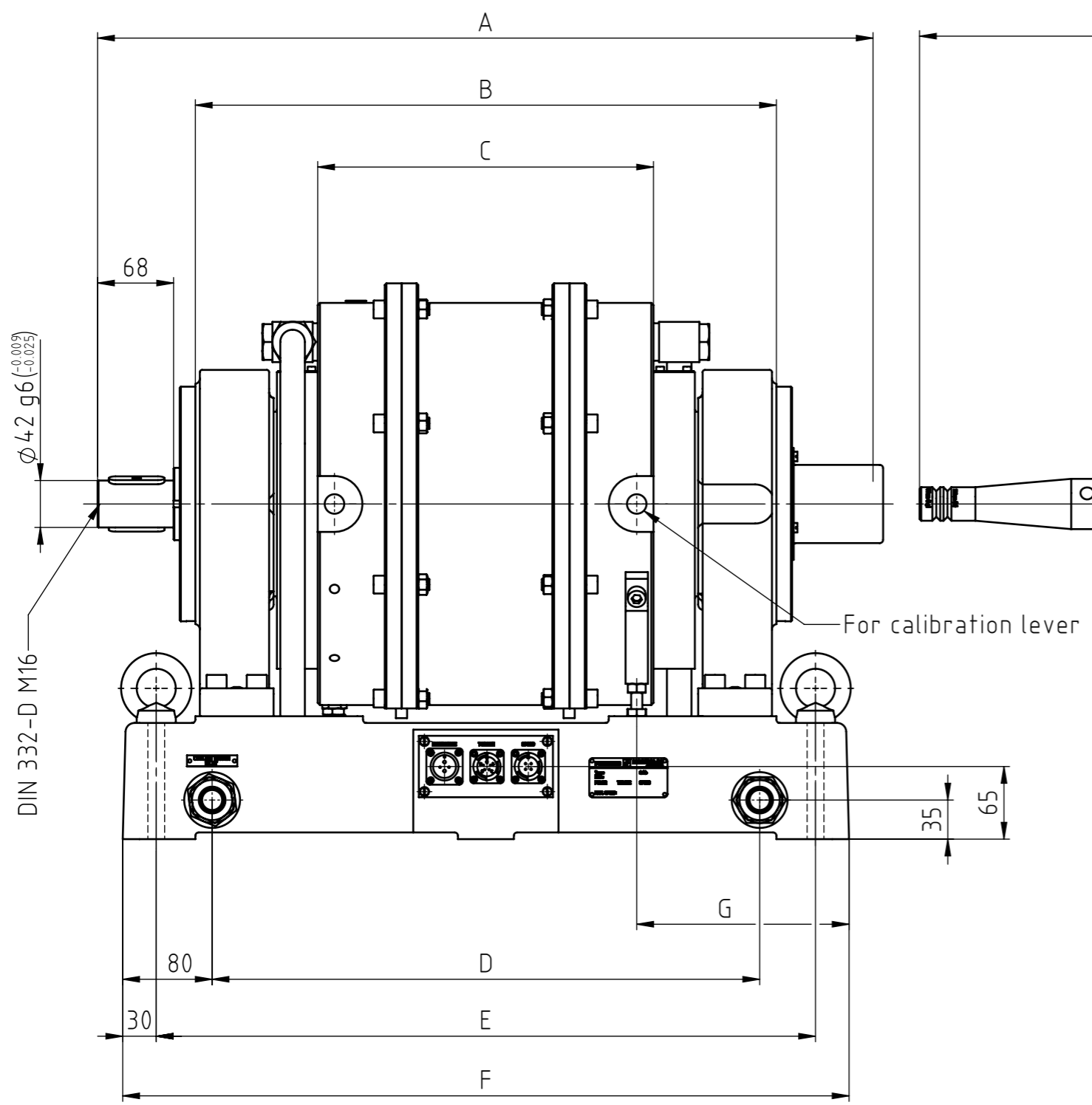

Type	A	B	C	D	E	F	G	H
1WB 15 / 1PB 15	544	370	150	490	590	650	265	-53
2WB 15 / 2PB 15	694	520	300	490	590	650	190	22
3WB 15 / -----	844	670	450	840	940	1000	290	-78
4WB 15 / 4PB 15	994	820	600	840	940	1000	215	-3

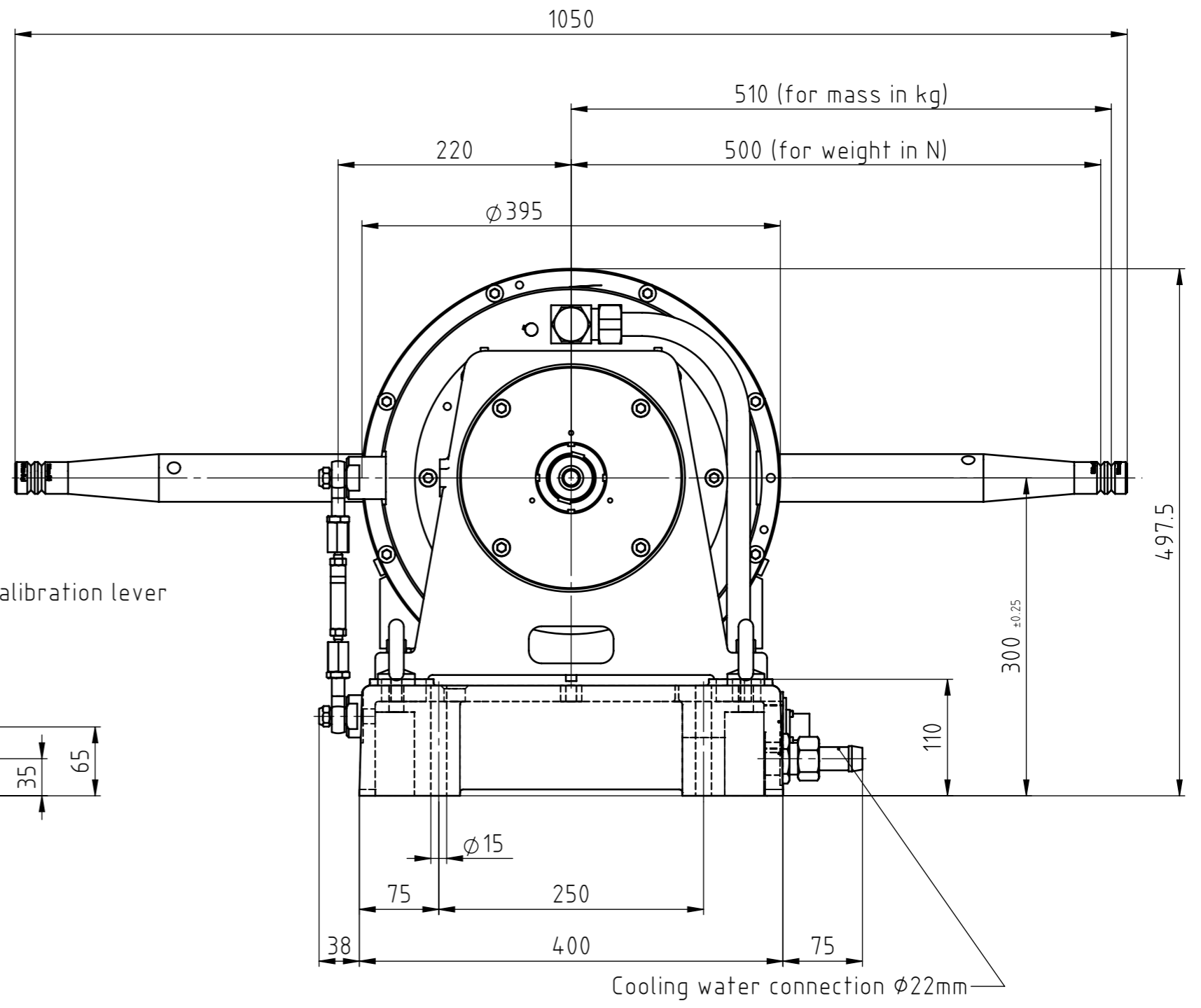

6								
5								
4								
3								
2								
1	02.09.19	18014	ajoy	blot	Text modification (Nm) by (for mass in kg) and (kpm) by (for weight in N); and remove the text 'Calibration with weight in kg'			
Rev.	Date	PM	Drawn	Appr.	Repl. by : Repl. for: VZB 100-900			
Tolerances: $\pm$ . . . mm to 50mm, $\pm$ . . . mm over 50mm								
Material: . . .					Scale 1:5		Drawn 03.04.97 A.Rappo Checked Approved	
Finish: . . .					DRAWING N°			
Dynamometers 1-4WB15 1-4PB15					314-101-000V011			