

MODEL	TORQUE MEASURE UNIT CODE (-XXX)	STOCK CODE	MAXIMUM TORQUE RANGE	DRAG TORQUE DE-ENERGIZED AT 1000 RPM	NOMINAL INPUT INERTIA		MAXIMUM POWER		MAXIMUM SPEED (RPM)	COOLING	FAN DESCRIPTION
					(lb•ft•s ²)	(kg•m ²)	5-MINUTE (Watts)	CONTINUOUS (Watts)			
HD-510-XXX	5N	006657	0.850 N m	5 mN m	8.05 x 10 ⁻⁵	1.09 x 10 ⁻⁴	750	375	25,000	COMPRESSED AIR* (7 CFM @ 1.75 PSI)	115V
	5NA	006658									220V
	6N	005715	120.0 oz in	0.5 oz in							115V
	6NA	005716									220V
	7N	005717	8.50 kg cm	0.05 kg cm							115V
	7NA	005718									220V
	8N	005719	850 mN m	5 mN m							115V
	8NA	005720									220V

SOLID MODEL AVAILABLE

3 DIMENSIONAL VIEW
SCALE 1 : 8

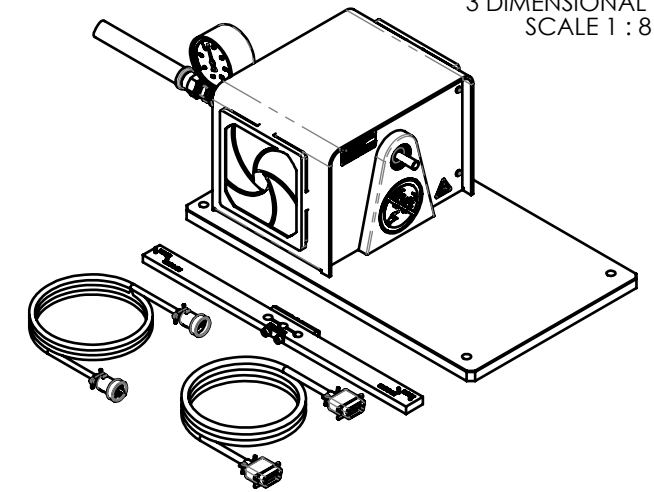

* REQUIRES AIR COOLING PROVIDED BY USER. REGULATOR AND FILTER PACKAGE IS PROVIDED AS STANDARD EQUIPMENT.

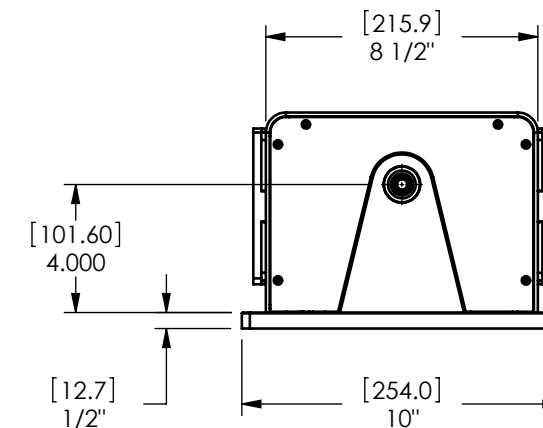
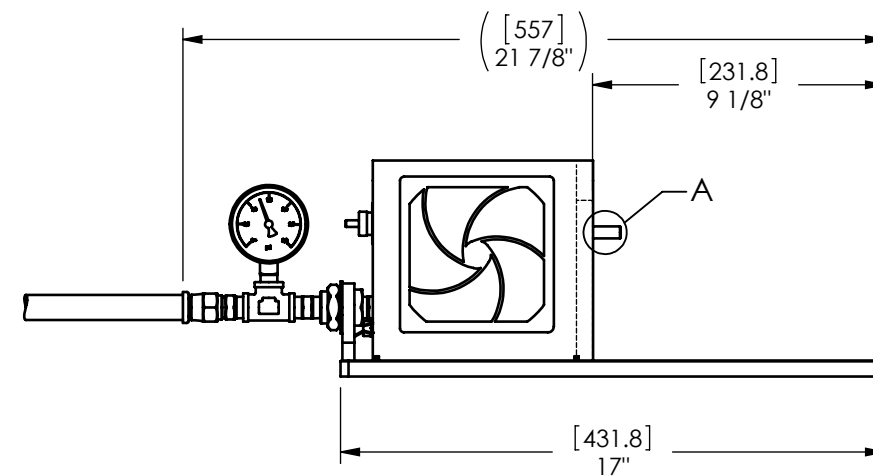
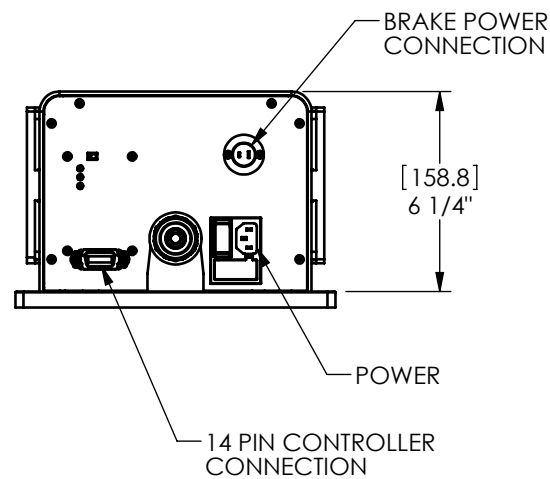
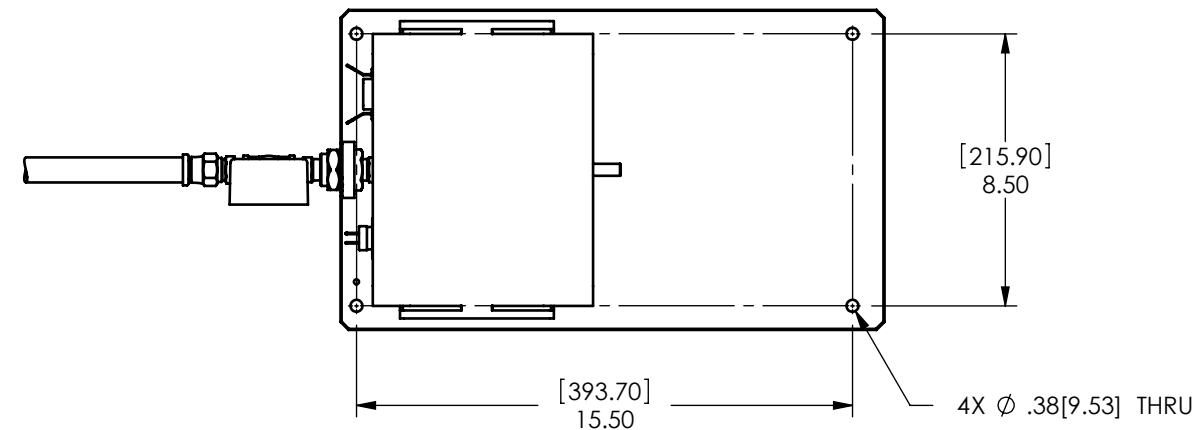
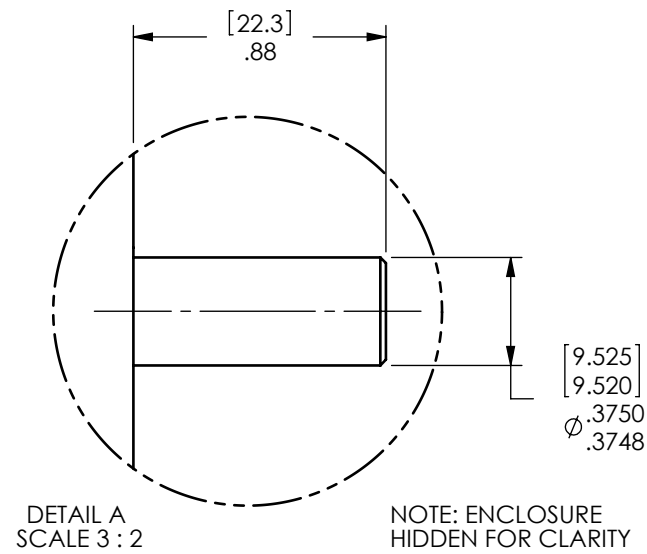

NOTE: DIMENSIONS IN [] ARE MILLIMETERS.

INSTALLATION DRAWING

MATERIAL: -	DESIGN	-	-		MAGTROL INC. 70 GARDENVILLE PKWY, W. BUFFALO, NEW YORK 14224-1322
	DRAWN	JEF	09/07/10		
FINISH: -	CHECKED	AJC	09/08/10	TITLE: HD-510 DYNAMOMETER	
	THIRD ANGLE PROJECTION			UNLESS OTHERWISE SPECIFIED: DIMENSIONS ARE IN INCHES DIAMETERS CONCENTRIC: .003 TIR FACES PERPENDICULAR: .003 INTERPRETATION PER ASME Y14.5M-1994 REMOVE ALL BURRS AND BREAK SHARP EDGES .005/.010 X 45° INSIDE CORNERS TO BE R .02 MAX TOLERANCES: .XX ± .01 X/Y ± 1/64" .XXX ± .005 ANG ± 1° SURFACE FINISH 125 RMS MAX	
THIS DRAWING AND SPECIFICATION CONTAINS PROPRIETARY INFORMATION TO MAGTROL INC. ANY DISCLOSURE OR REPRODUCTION OF THIS DOCUMENT WITHOUT WRITTEN AUTHORIZATION FROM MAGTROL INC. IS EXPRESSLY PROHIBITED				DWG NO:	HD-510
				REV	B
SIZE		SCALE			
B		1:6			