

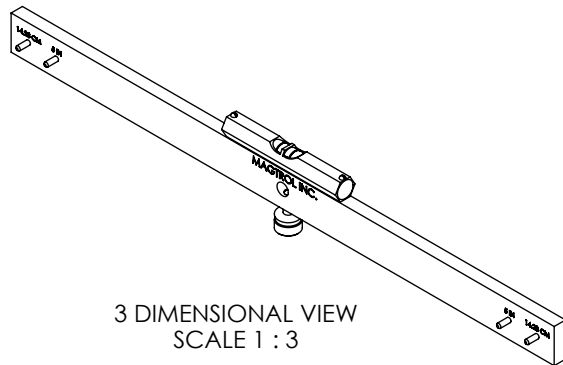

NOTES:

1. DIMENSIONS ARE FOR REFERENCE ONLY
2. PIN LOCATIONS ARE  $\pm .005"$  [.13 mm] FROM CENTER

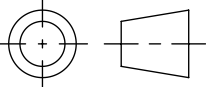

MATERIAL: -	DESIGN	JEF	02/10/05	 <b>MAGTROL INC.</b> 70 GARDENVILLE PKWY, W. BUFFALO, NEW YORK 14224-1322
	DRAWN	JEF	02/10/05	
FINISH: -	CHECKED	DTW	02/10/05	TITLE CB-400, CAL BEAM ASSY
	THIRD ANGLE PROJECTION 			UNLESS OTHERWISE SPECIFIED: DIMENSIONS ARE IN INCHES, DIAMETERS CONCENTRIC-.003 TIR, FACES PERPENDICULAR-.003 INTERPRETATION PER ASME Y14.5M-1994 REMOVE ALL BURRS AND BREAK SHARP EDGES .005/.010 X 45°, ALL INSIDE CORNERS TO BE .02 R MAX. TOLERANCES .XX $\pm .01$ FRAC. $\pm 1/64"$ .XXX $\pm .005$ ANG. $\pm 1^\circ$ SURFACE FINISH 125 RMS MAX. U.O.S.
THIS DRAWING AND SPECIFICATION CONTAINS PROPRIETARY INFORMATION TO MAGTROL INC. ANY DISCLOSURE OR REPRODUCTION OF THIS DOCUMENT WITHOUT WRITTEN AUTHORIZATION FROM MAGTROL INC. IS EXPRESSLY PROHIBITED				USED ON: - SIMILAR TO: 400400 DWG. NO. <b>400401</b> REV <span style="float: right;"><b>B</b></span>
SIZE <b>A</b> SCALE <b>1:2</b> SHEET # <b>2 OF 2</b>				