

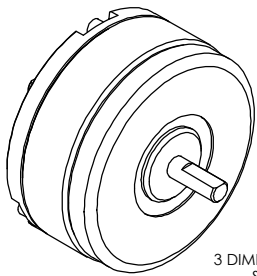

SOLID MODEL AVAILABLE

MODEL	STOCK CODE	MINIMUM TORQUE (oz in)	MAXIMUM SPEED (RPM)	KINETIC POWER RATINGS		EXTERNAL INERTIA (lb in s ²)	ANGULAR ACCELERATION (rad/s ²)
				5 MINUTE (watts)	CONTINUOUS (watts)		
HPM-16	005788	16	6,340	75	20	5.6 X 10 ⁻⁵	17,900

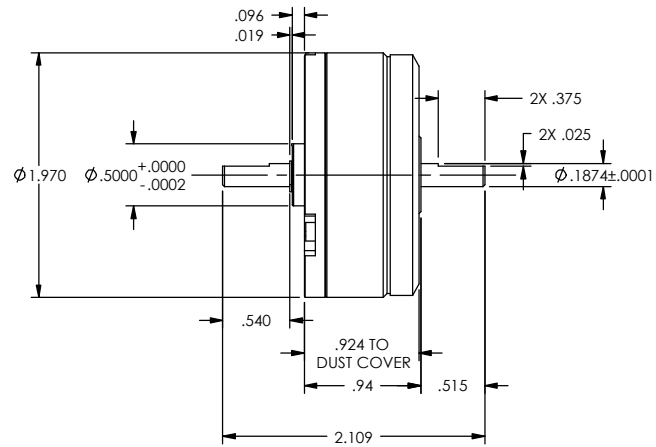
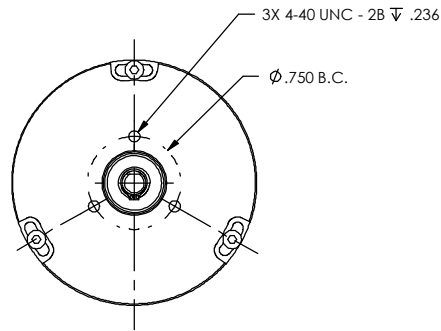

3 DIMENSIONAL VIEW
 SCALE 1 : 1

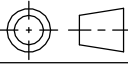
MATERIAL: -	DESIGN	-	-		MAGTROL INC.	
	DRAWN	AJC	08/23/06		70 GARDENVILLE PKWY, W. BUFFALO, NEW YORK 14224-1322	
FINISH: -	CHECKED	DTW	08/23/06	TITLE		
	THIRD ANGLE PROJECTION 			UNLESS OTHERWISE SPECIFIED: DIMENSIONS ARE IN INCHES. DIAMETERS CONCENTRIC: .003 TIR, FACES PERPENDICULAR: .003 INTERPRETATION PER ASME Y14.5M-1994 REMOVE ALL BURRS AND BREAK SHARP EDGES .005/.010 X 45°, ALL INSIDE CORNERS TO BE .02 R MAX. TOLERANCES: .XX ± .01 FRAC. ± 1/64" .XXX ± .005 ANG. ± 1° SURFACE FINISH 125 RMS MAX. U.O.S.		
THIS DRAWING AND SPECIFICATION CONTAINS PROPRIETARY INFORMATION TO MAGTROL INC. ANY DISCLOSURE OR REPRODUCTION OF THIS DOCUMENT WITHOUT WRITTEN AUTHORIZATION FROM MAGTROL INC. IS EXPRESSLY PROHIBITED				HPM-16 PERMANENT MAGNETIC BRAKE		
				DWG. NO. HPM-16		REV -
SIZE B		SCALE 1:1		SHEET # 2 OF 2		