

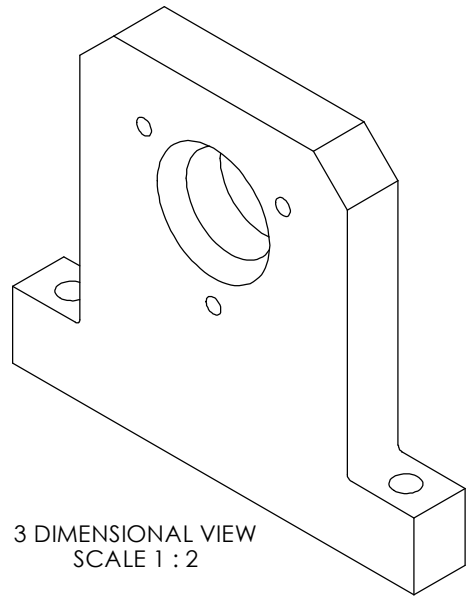

REVISIONS				
LETTER	DATE	BY	ECN	DESCRIPTION

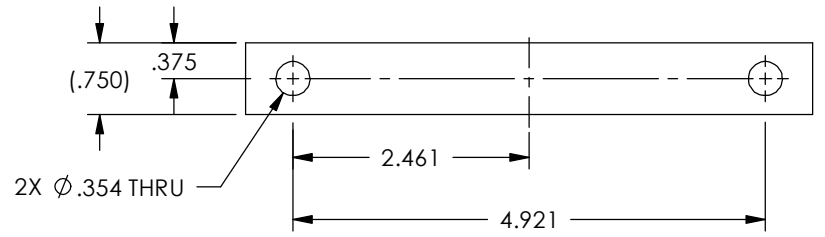
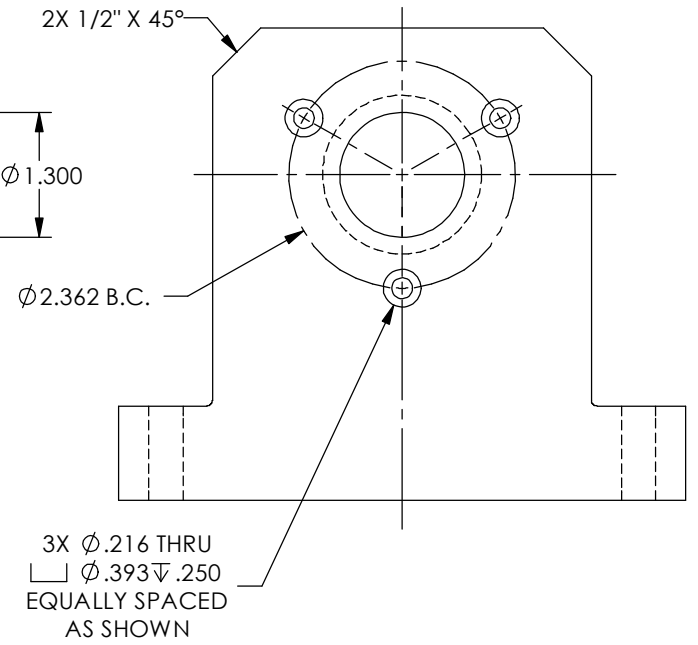
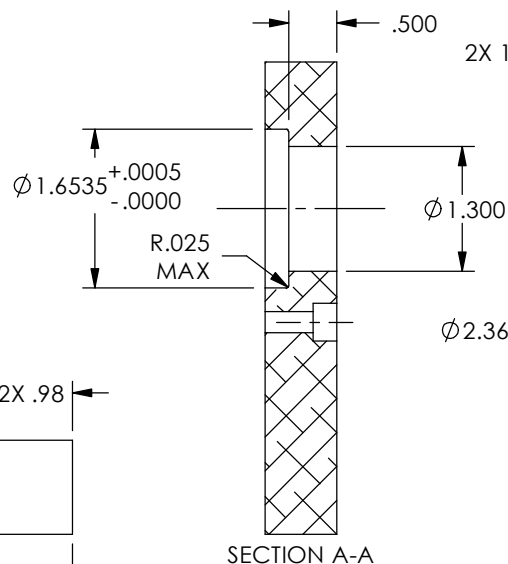
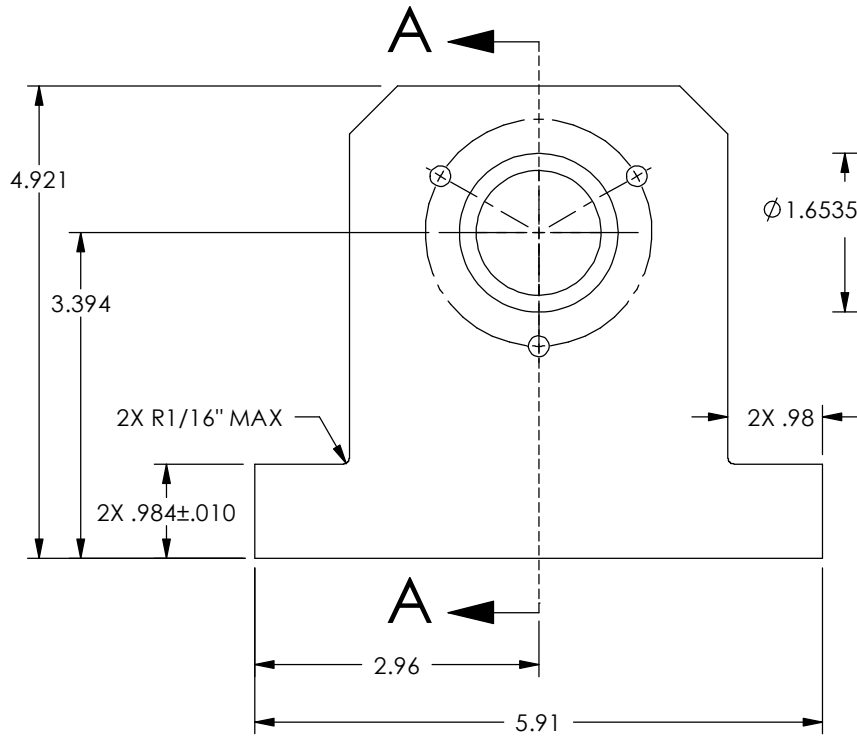

MATERIAL: MIC-6 ALUMINUM	DESIGN	AJC	07/07/05
	DRAWN	AJC	07/07/05
FINISH: ANODIZE TYPE II CLEAR	CHECKED	DTW	07/07/05
	UNLESS OTHERWISE SPECIFIED: DIMENSIONS ARE IN INCHES, DIAMETERS CONCENTRIC-.003 TIR, FACES PERPENDICULAR-.003 INTERPRETATION PER ASME Y14.5M-1994 REMOVE ALL BURRS AND BREAK SHARP EDGES .005/.010 X 45°, ALL INSIDE CORNERS TO BE .02 R MAX. TOLERANCES .XX ±.01 FRAC. ±1/64" .XXX ±.005 ANG. ±1° SURFACE FINISH 125 RMS MAX. U.O.S.		
THIRD ANGLE PROJECTION			
THIS DRAWING AND SPECIFICATION CONTAINS PROPRIETARY INFORMATION TO MAGTROL INC. ANY DISCLOSURE OR REPRODUCTION OF THIS DOCUMENT WITHOUT WRITTEN AUTHORIZATION FROM MAGTROL INC. IS EXPRESSLY PROHIBITED			

 MAGTROL INC. 70 GARDENVILLE PKWY, W. BUFFALO, NEW YORK 14224-1322	TITLE PILLOW BLOCK, HCF-250M	
	USED ON: HCF-250M SIMILAR TO: 404858, SK04JAN13	
DWG. NO.	404830	REV -
SIZE A	SCALE 1:2	SHEET # 1 OF 1