

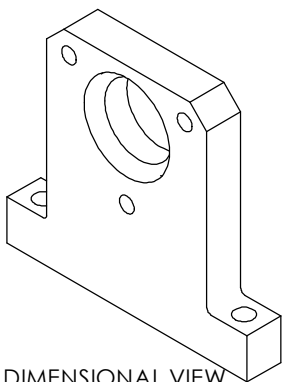

REVISIONS				
LETTER	DATE	BY	ECN	DESCRIPTION

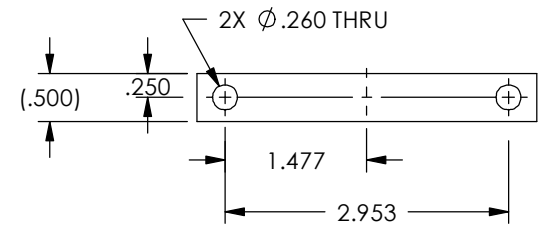
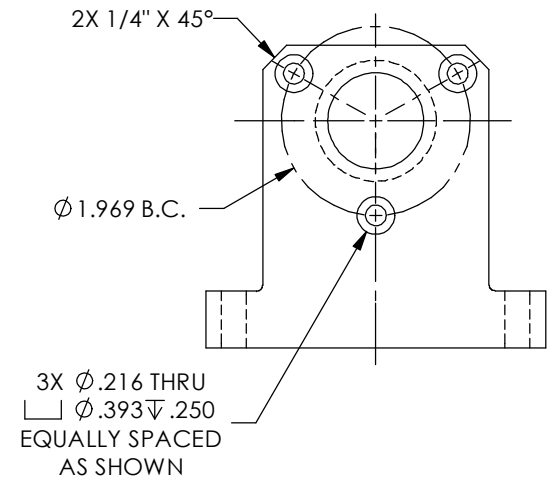
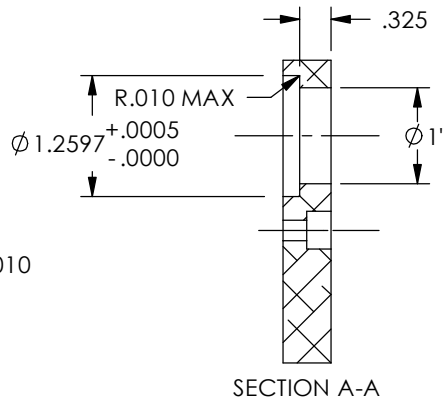
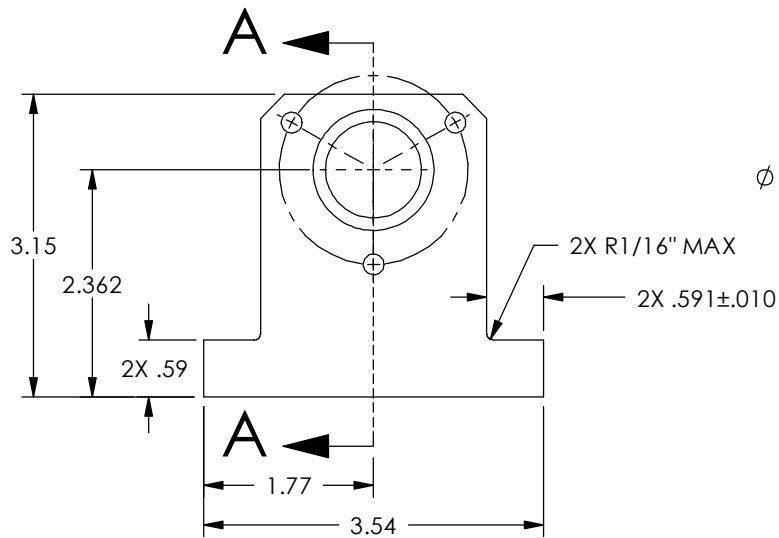
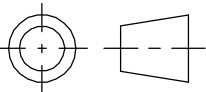

3 DIMENSIONAL VIEW
SCALE 1 : 2

MATERIAL: MIC-6 ALUMINUM	DESIGN	AJC	03/09/06	 MAGTROL INC. 70 GARDENVILLE PKWY, W. BUFFALO, NEW YORK 14224-1322
	DRAWN	AJC	03/09/06	
FINISH: ANODIZE TYPE II CLEAR	CHECKED	DTW	03/09/06	TITLE PILLOW BLOCK, HCF-140M
	THIRD ANGLE PROJECTION 			UNLESS OTHERWISE SPECIFIED: DIMENSIONS ARE IN INCHES, DIAMETERS CONCENTRIC-.003 TIR, FACES PERPENDICULAR-.003 INTERPRETATION PER ASME Y14.5M-1994 REMOVE ALL BURRS AND BREAK SHARP EDGES .005/.010 X 45°, ALL INSIDE CORNERS TO BE .02 R MAX. TOLERANCES .XX ±.01 FRAC.±1/64" .XXX ±.005 ANG. ±1° SURFACE FINISH 125 RMS MAX. U.O.S.
THIS DRAWING AND SPECIFICATION CONTAINS PROPRIETARY INFORMATION TO MAGTROL INC. ANY DISCLOSURE OR REPRODUCTION OF THIS DOCUMENT WITHOUT WRITTEN AUTHORIZATION FROM MAGTROL INC. IS EXPRESSLY PROHIBITED				USED ON: - SIMILAR TO: 404724 DWG. NO. 404725 REV -
			SIZE A	SCALE 1:2
			SHEET # 1 OF 1	