

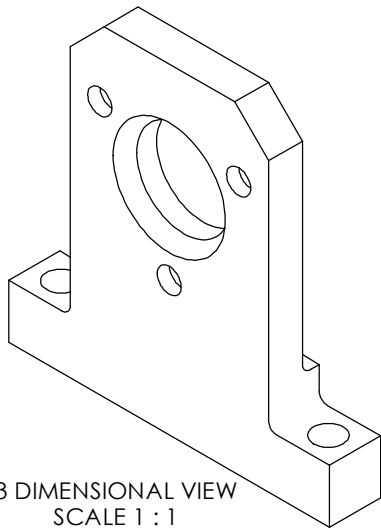

REVISIONS				
LETTER	DATE	BY	ECN	DESCRIPTION
A	10/14/2005	AJC	-	ADDED 1/8" X 5/8" RELIEF CUT
B	3/10/2006	AJC	6239	.160 WAS .187

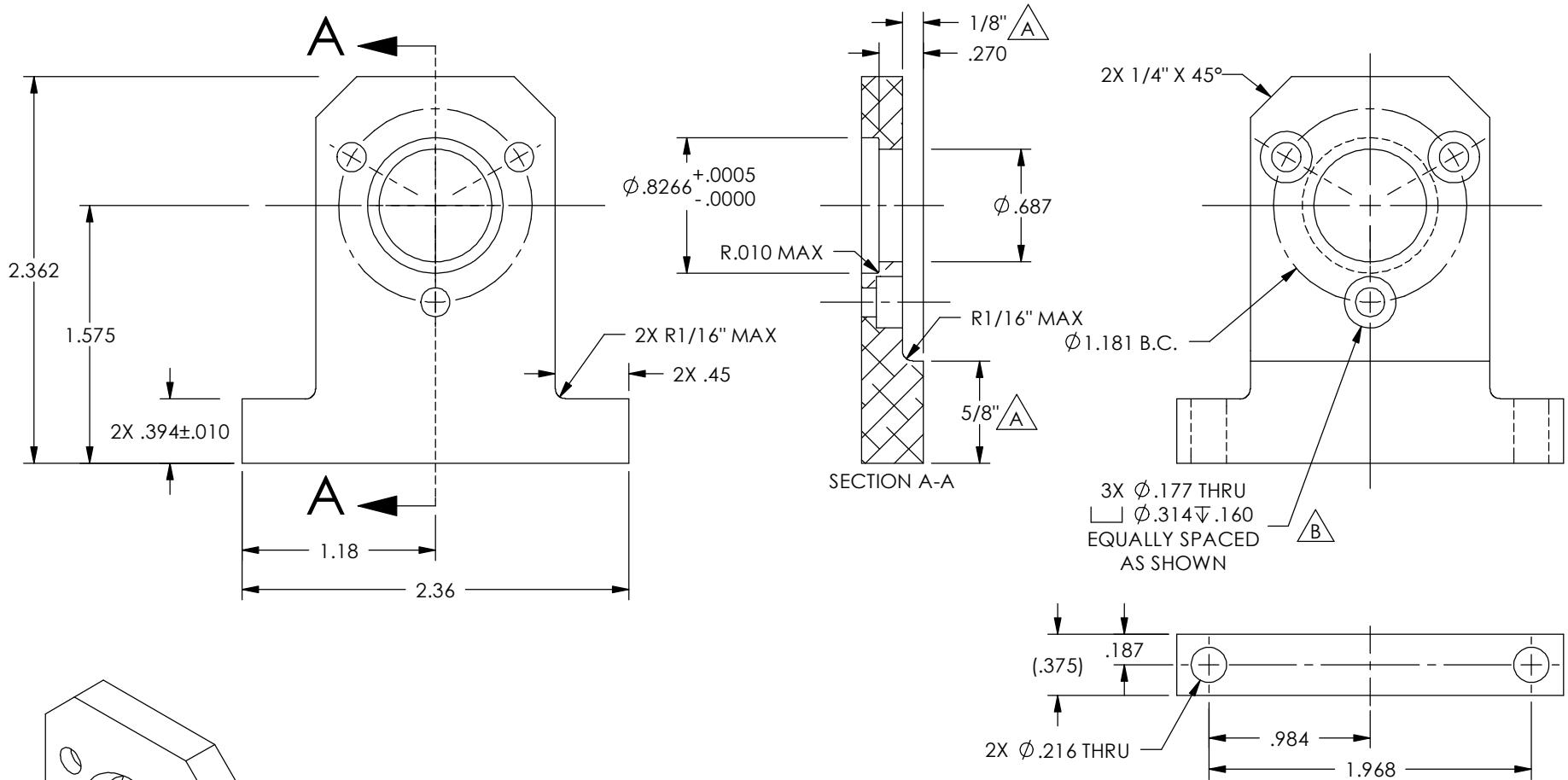
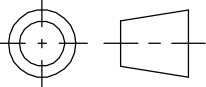

MATERIAL: MIC-6 ALUMINUM	DESIGN	AJC	04/26/05	 MAGTROL INC. 70 GARDENVILLE PKWY, W. BUFFALO, NEW YORK 14224-1322
	DRAWN	AJC	04/26/05	
FINISH: ANODIZE TYPE II CLEAR	CHECKED	DTW	04/26/05	TITLE PILLOW BLOCK, HCF-32M
	THIRD ANGLE PROJECTION 			USED ON: HCF-32M SIMILAR TO: 404705
THIS DRAWING AND SPECIFICATION CONTAINS PROPRIETARY INFORMATION TO MAGTROL INC. ANY DISCLOSURE OR REPRODUCTION OF THIS DOCUMENT WITHOUT WRITTEN AUTHORIZATION FROM MAGTROL INC. IS EXPRESSLY PROHIBITED			UNLESS OTHERWISE SPECIFIED: DIMENSIONS ARE IN INCHES, DIAMETERS CONCENTRIC-.003 TIR, FACES PERPENDICULAR-.003 INTERPRETATION PER ASME Y14.5M-1994 REMOVE ALL BURRS AND BREAK SHARP EDGES .005/.010 X 45°, ALL INSIDE CORNERS TO BE .02 R MAX. TOLERANCES .XX ±.01 FRAC.±1/64" .XXX ±.005 ANG. ±1° SURFACE FINISH 125 RMS MAX. U.O.S.	
			DWG. NO.	REV
			404724	B
SIZE		SCALE	SHEET #	
A		1:1	1 OF 1	