

MAGTROL

MODEL 6400

Torque Transducer Display

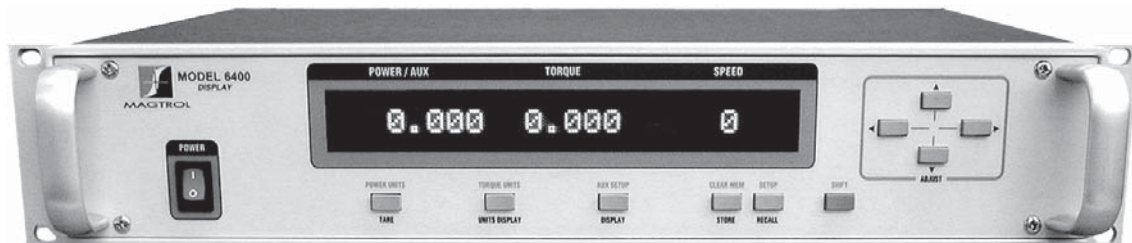

User's Manual

While every precaution has been exercised in the compilation of this document to ensure the accuracy of its contents, Magtrol, Inc. assumes no responsibility for errors or omissions. Additionally, no liability is assumed for any damages that may result from the use of the information contained within this publication.

COPYRIGHT

Copyright ©2000-2004 Magtrol, Inc. All rights reserved.

Copying or reproduction of all or any part of the contents of this manual without the express permission of Magtrol is strictly prohibited.

TRADEMARKS

LabVIEW™ is a trademark of National Instruments Corporation.

National Instruments™ is a trademark of National Instruments Corporation.

Windows® is a registered trademark of Microsoft Corporation.

Safety Precautions



1. Make sure that all Magtrol Torque Transducers and electronic products are earth-grounded, to ensure personal safety and proper operation.
2. Securely ground the 6400 Torque Transducer Display case by connecting a good earth ground at the ground stud located on the rear panel of the unit. Use a number 12 AWG, or larger wire.
3. Check line voltage before operating.
4. Make sure that torque transducers and motors under test are equipped with appropriate safety guards.

Revisions To This Manual

The contents of this manual are subject to change without prior notice. Should revisions be necessary, updates to all Magtrol User's Manuals can be found at Magtrol's web site at www.magtrol.com/support/manuals.htm.

Please compare the date of this manual with the revision date on the web site, then refer to the manual's Table of Revisions for any changes/updates that have been made since this edition.

REVISION DATE

3rd Edition, revision B – June 2004

Date	Edition	Change	Section(s)
06/10/04	3rd Edition, rev. B	Added torque and speed outputs for data acquisition system	1.3, 2.4, 2.5
06/10/04	3rd Edition, rev. B	Updated schematic drawings	C.1 – C.4
09/19/03	3rd Edition, rev. A	Updated schematic drawings	C.1 and C.3
11/08/01	3rd Edition	Added more detail and included display drawings	all
08/17/01	2nd Edition	Reformatting of entire manual - content was unaltered	all

Table of Contents

SAFETY PRECAUTIONS	i
REVISIONS TO THIS MANUAL	ii
REVISION DATE	ii
TABLE OF REVISIONS	ii
TABLE OF CONTENTS	iii
TABLE OF FIGURES	v
PREFACE	vi
PURPOSE OF THIS MANUAL	vi
WHO SHOULD USE THIS MANUAL	vi
MANUAL ORGANIZATION	vi
CONVENTIONS USED IN THIS MANUAL	vii
1. INTRODUCTION	1
1.1 UNPACKING YOUR 6400 TORQUE TRANSDUCER DISPLAY	1
1.2 FEATURES OF THE 6400 TORQUE TRANSDUCER DISPLAY	1
1.3 DATA SHEET	3
2. CONTROLS	5
2.1 FRONT PANEL	5
2.2 FRONT PANEL CONTROLS AND BUTTONS	5
2.2.1 Enabling Secondary Functions	5
2.2.2 Using Front Panel Controls and Buttons	6
2.3 VACUUM FLUORESCENT DISPLAY (VFD)	7
2.3.1 Contrast Settings	7
2.4 REAR PANEL	8
2.5 REAR PANEL INPUTS AND OUTPUTS	8
3. INSTALLATION/CONFIGURATION	10
3.1 POWERING UP THE 6400	10
3.1.1 Setting Unit for Line Voltage	10
3.1.2 Self-Test	10
3.1.3 Main Menu	12
4. MANUALLY CONTROLLED OPERATION	13
4.1 SETTING DESIRED OPERATING PARAMETERS	13
4.1.1 Power Units Setup	13
4.1.2 Torque Units Setup	13
4.1.3 System Parameter Setup	14
4.1.4 Auxiliary Scale Factor Setup	16
4.1.5 Pass/Fail Parameter Setup	17
4.1.6 Input/Output (I/O) Parameter Setup	19
4.2 USING INTERNAL MEMORY	19
4.2.1 Storing Data Points	19
4.2.2 Recalling Data Points	20
4.2.3 Exiting the Memory Mode	20
4.2.4 Clearing the Memory	20
4.3 USING THE TARE FUNCTION	20
4.4 SYSTEM TEST	21

5. COMPUTER CONTROLLED OPERATION	22
5.1 ABOUT THE GPIB INTERFACE	22
5.1.1 Connecting the GPIB (IEEE-488) Cable	22
5.1.2 Changing the GPIB Primary Address	23
5.2 ABOUT THE RS-232 INTERFACE	23
5.2.1 Connection	23
5.2.2 Communication Parameters	24
5.2.3 Baud Rate	24
5.3 CHECKING THE 6400-TO-PC CONNECTION	24
5.4 DATA FORMAT	25
5.5 PROGRAMMING	26
5.5.1 Data Termination Characters	26
5.4.2 Timeout	26
5.6 6400 COMMAND SET	27
5.6.1 Communication Commands	27
5.6.2 Setup Commands	28
5.6.3 Calibration Commands	29
6. CALIBRATION	30
6.1 CLOSED-BOX CALIBRATION	30
6.2 CALIBRATION SCHEDULE	30
6.3 BASIC CALIBRATION PROCESS	30
6.3.1 Initial Calibration Procedure	30
6.3.2 Torque Offset and Gain	31
6.3.3 Auxiliary Input Offset and Gain	32
7. TROUBLESHOOTING	34
APPENDIX A: LABVIEW PROGRAMMING EXAMPLES	35
A.1 SIMPLE READ	35
APPENDIX B: FRONT PANEL/DISPLAY MENU FLOW CHARTS	36
B.1 SETUP MENU	36
B.2 TORQUE UNITS MENU	37
B.3 AUX SETUP MENU	38
B.4 POWER UNITS MENU	38
APPENDIX C: SCHEMATICS	39
C.1 ANALOG SECTION	39
C.2 CPU SECTION	40
C.3 INPUT/OUTPUT (I/O) SECTION	41
C.4 POWER SUPPLY SECTION	42
C.5 KEYPAD	43
INDEX	44
MAGTROL LIMITED WARRANTY	46
CLAIMS	46

TABLE OF FIGURES

CHAPTER 2		
Figure 2-1	Front Panel	5
Figure 2-2	Contrast Setup Menu	7
Figure 2-3	Rear Panel	8
Figure 2-4	Torque Meter Connector	8
Figure 2-5	RS-232C Interface	8
Figure 2-6	GPIB/IEEE-488 Interface	9
CHAPTER 3		
Figure 3-1	Cable and Connection Diagrams	11
Figure 3-2	Program Download Display	11
Figure 3-3	Title Display	11
Figure 3-4	Revision Display	12
Figure 3-5	Main Menu	12
CHAPTER 4		
Figure 4-1	Power Units Setup Menu	13
Figure 4-2	Torque Units Setup Menu	13
Figure 4-3	Max Power Setup Display	14
Figure 4-4	Power Overload Display	14
Figure 4-5	Direction Input Setup Menu	15
Figure 4-6	Encoder Setup Display	15
Figure 4-7	Torque Scale Factor Setup Display	16
Figure 4-8	Auxiliary Scale Factor Setup Display	16
Figure 4-9	Torque Pass/Fail Setup Menu	17
Figure 4-10	High Limit Setup Display	17
Figure 4-11	Low Limit Setup Display	17
Figure 4-12	Speed Pass/Fail Setup Menu	18
Figure 4-13	Auxiliary Input Pass/Fail Setup Menu	18
Figure 4-14	Pass/Fail Display Example	18
Figure 4-15	GPIB Address Setup Menu	19
Figure 4-16	RS-232 Baud Rate Setup Menu	19
Figure 4-17	Store Display	19
Figure 4-18	Recall Display	20
Figure 4-19	Main Menu with Recall Function Enabled	20
Figure 4-20	Torque Transducer at Full Scale	21
CHAPTER 5		
Figure 5-1	GPIB Installation	22
Figure 5-2	RS-232 Interface	23
Figure 5-3	Cable Connection Using Null Modem	23
CHAPTER 6		
Figure 6-1	Software Revision Date Display	31
Figure 6-2	Torque Offset and Gain Display	31
Figure 6-3	Zero Torque Display	31
Figure 6-4	Full Scale Torque Display 1	32
Figure 6-5	Full Scale Torque Display 2	32

Preface

PURPOSE OF THIS MANUAL

This manual contains all the information required for the installation and general use of the Model 6400 Torque Transducer Display. To achieve maximum capability and ensure proper use of the instrument, please read this manual in its entirety before operating. Keep the manual in a safe place for quick reference whenever a question should arise.

WHO SHOULD USE THIS MANUAL

This manual is intended for bench test operators who are going to use the 6400 Torque Transducer Display in conjunction with any Magtrol In-Line Torque Transducer.

MANUAL ORGANIZATION

This section gives an overview of the structure of the manual and the information contained within it. Some information has been deliberately repeated in different sections of the document to minimize cross-referencing and to facilitate understanding through reiteration.

The structure of the manual is as follows:

- Chapter 1: INTRODUCTION - Contains the technical data sheet for the 6400 Torque Transducer Display, which describes the unit and provides its mechanical and electrical characteristics.
- Chapter 2: CONTROLS - Description of the elements located on the front and rear panels of the unit.
- Chapter 3: INSTALLATION/CONFIGURATION - Provides information needed for setup of the 6400.
- Chapter 4: MANUALLY CONTROLLED OPERATION - How to run a test when the 6400 is used as a stand-alone unit. Includes information on setting operating parameters and using internal memory.
- Chapter 5: COMPUTER CONTROLLED OPERATION - How to run a test when the 6400 is used with a personal computer. Includes information on GPIB (IEEE-488) and Serial (RS-232) interface, data format, programming and command set.
- Chapter 6: CALIBRATION - Provides recommended calibration schedules along with step-by-step instructions for the calibration procedure.
- Chapter 7: TROUBLESHOOTING - Solutions to common problems encountered during setup and testing.
- Appendix A: LABVIEW™ PROGRAMMING EXAMPLES - Example of communicating with the 6400 when writing your own software.
- Appendix B: FRONT PANEL/DISPLAY MENU FLOW CHARTS - A visual display of various setup procedures.
- Appendix C: SCHEMATICS - For the analog, CPU, I/O, power supply and keypad sections.
- Glossary: List of abbreviations and terms used in this manual, along with their definitions.

CONVENTIONS USED IN THIS MANUAL

The following symbols and type styles may be used in this manual to highlight certain parts of the text:



Note: This is intended to draw the operator's attention to complementary information or advice relating to the subject being treated. It introduces information enabling the correct and optimal functioning of the product to be obtained.



CAUTION: THIS IS USED TO DRAW THE OPERATOR'S ATTENTION TO INFORMATION, DIRECTIVES, PROCEDURES, ETC. WHICH, IF IGNORED, MAY RESULT IN DAMAGE BEING CAUSED TO THE MATERIAL BEING USED. THE ASSOCIATED TEXT DESCRIBES THE NECESSARY PRECAUTIONS TO TAKE AND THE CONSEQUENCES THAT MAY ARISE IF THE PRECAUTIONS ARE IGNORED.



WARNING! THIS INTRODUCES DIRECTIVES, PROCEDURES, PRECAUTIONARY MEASURES, ETC. WHICH MUST BE EXECUTED OR FOLLOWED WITH THE UTMOST CARE AND ATTENTION, OTHERWISE THE PERSONAL SAFETY OF THE OPERATOR OR THIRD PARTY MAY BE PUT AT RISK. THE READER MUST ABSOLUTELY TAKE NOTE OF THE ACCOMPANYING TEXT, AND ACT UPON IT, BEFORE PROCEEDING FURTHER.

1. Introduction

1.1 UNPACKING YOUR 6400 TORQUE TRANSDUCER DISPLAY

Your 6400 Torque Transducer Display was packaged in reusable, shock resistant packing material that will protect the instrument during normal handling.

1. Make sure the carton contains the following:

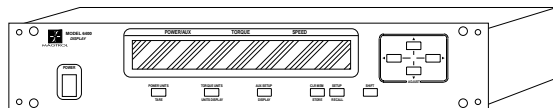

6400 Torque Transducer Display

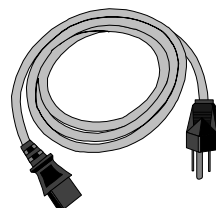

Line cord

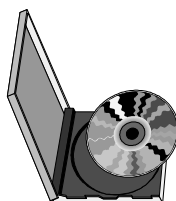

Magtrol
User Manual
CD-Rom

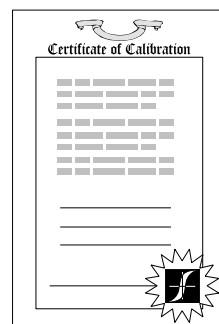

Calibration Certificate

2. Inspect the contents for any evidence of damage in shipping. In the event of shipping damage, immediately notify the carrier and Magtrol's Customer Service Department.



Note: Save all shipping cartons and packaging material for reuse when returning the instrument for calibration or servicing.

1.2 FEATURES OF THE 6400 TORQUE TRANSDUCER DISPLAY

Designed specifically for use with Magtrol's In-Line Torque Transducers, the new Model 6400 Torque Transducer Display powers the transducer and utilizes high speed digital signal processing to display torque, speed, mechanical power and direction of rotation. The 6400 can be used as a basic display, as an interface with Magtrol TM Software or on the production line. Its features include:

- **High Quality, Easy-to-Read Display:** Vacuum fluorescent readout with large digits.
- **High-Speed Data Acquisition:** 100 torque and speed readings per second via IEEE (GPIB) bus.

- **Pass/Fail Testing:** Upper and lower limits are programmable for torque, speed, and auxiliary input.
- **Internal Data Storage:** Nonvolatile memory of up to 100 data points.
- **Overload Protection:** Maximum power limit can be programmed to warn user of overload condition.
- **Two Standard Computer Interfaces:** RS-232 and IEEE-488.
- **Additional Analog Input:** Accepts any ± 10 VDC transducer.
- **Torque Measurement Options:** Standard English, metric and SI settings.
- **Closed-Box Calibration of Torque and Auxiliary Input:** Eliminates need to open box for adjustments.

1.3 DATA SHEET

Model 6400 Torque Transducer Display

FEATURES

- For use with all Magtrol TM, TMHS and TMB Torque Transducers
- Pass/Fail Testing for torque, speed and auxiliary input
- BITE: Built-In Test Equipment
- RS-232 & IEEE-488 Interfaces
- High Speed Data Acquisition: 100 torque and speed readings per second via IEEE bus
- High Quality, Easy-to-Read Vacuum Fluorescent Readout: Displays torque, speed, power and direction of rotation
- Torque Measurement Options: Standard English, metric and SI settings
- Overload Indication
- Tare Function
- Internal Data Storage: Up to 100 data points
- Auxiliary ± 10 VDC Analog Input for additional transducer
- Access to TM signals via back panel BNC connectors
- Interfaces with Magtrol TM Software
- Closed Box Calibration
- 19" (482.6 mm) Rack Mounts with Handles



The 6400 can be used as a basic display, as an interface with Magtrol TM Software or on the production line using its pass/fail feature. The unit includes an auxiliary analog input for the option of testing with an additional transducer and a special tare function to help offset any slight residuals caused by couplings or suspended loads. The 6400 also has IEEE-488 and RS-232 interface capabilities, allowing a PC-controlled environment that can yield high data acquisition rates of up to 100 torque and speed readings per second. With Magtrol's TM Software (sold separately), the data for torque, speed and mechanical power can be automatically collected, saved, displayed graphically, printed or exported.

PASS/FAIL MOTOR TESTING

The Model 6400 comes with an easy-to-use motor testing Pass/Fail feature. This feature is ideal for quick pass/fail (go/no go) testing in production and incoming inspection applications.

When the 6400 is operated in the Pass/Fail mode, one of three readings is used as the tested parameter: torque, speed or auxiliary transducer. The two parameters not used are set with user defined upper and lower acceptable limits. As the motor is loaded to the tested parameter value (for example, speed), the other two parameters (in this case, torque and transducer) will indicate PASS or FAIL. The display will show pass or fail, or can be toggled to display the actual values.

DESCRIPTION

Magtrol's Model 6400 Torque Transducer Display is designed specifically for use with all TM, TMHS and TMB Torque Transducers. This easy-to-use device powers the transducer and utilizes high speed Digital Signal Processing (DSP) to display torque, speed, mechanical power and direction of rotation.

SYSTEM CONFIGURATION

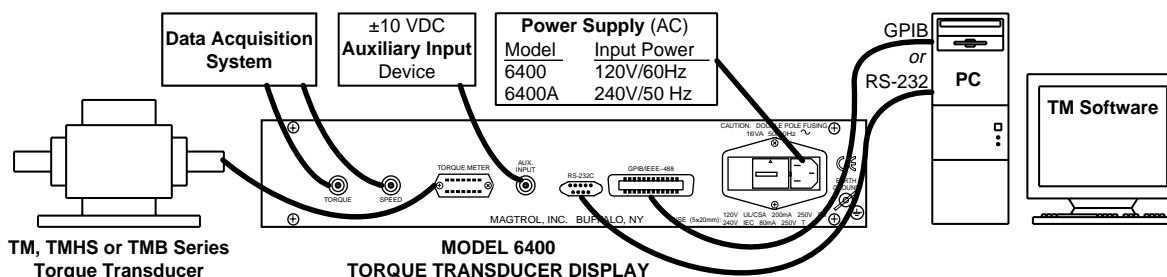

Specifications

6400

MEASUREMENT CHARACTERISTICS	
Speed Accuracy	0.01% of reading from 10 rpm to 100,000 rpm
Torque Accuracy	0.1% of range (± 10 V)
Aux Accuracy	0.1% of range (± 10 V)
Maximum Speed	99,999 rpm
ELECTRICAL CHARACTERISTICS	
Fuses (5 x 20 mm)	Power (120 V): 200 mA UL/CSA 250 V SB Power (240 V): 80 mA IEC 250 V T
Power Requirements	16 VA
Voltage Requirements	120/240 V 60/50 Hz
INPUTS AND OUTPUTS	
Auxiliary Input	± 10 VDC
Maximum Torque Input	± 10 VDC
Torque Output BNC	± 10 VDC (direct from TM)
Speed Output BNC	0 to 5 VDC pulse (direct from TM)

ENVIRONMENTAL CHARACTERISTICS	
Operating Temperature	18 °C to 25 °C
Relative Humidity	< 80%
Temperature Coefficient	0.001% of range/°C
MECHANICAL CHARACTERISTICS	
Width	19.0 in 483 mm
Depth	12.4 in 315 mm
Depth with handles	13.8 in 351 mm
Height	3.5 in 89 mm
Weight	14.5 lb 6.58 kg

FRONT PANEL

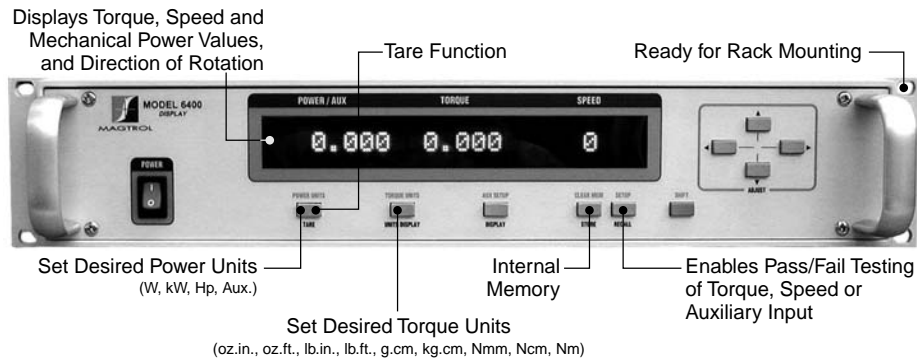

REAR PANEL

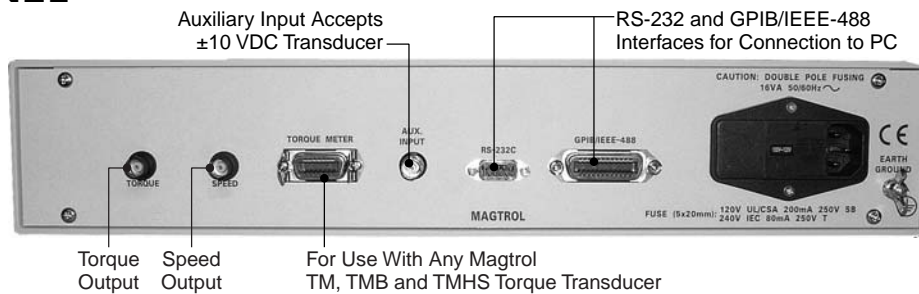

SYSTEM OPTIONS/ACCESSORIES

Description	Model/Part #
Torque Transducer Software	SW-TM-WE
Transducer Software with source codes	SW-TM-WS
Torque Transducer Connector Cable-5/10/20 m	ER 113-01/02/03

ORDERING INFORMATION

6400	Torque Transducer Display	120 VAC
6400A	Torque Transducer Display	240 VAC

Due to the continual development of our products, we reserve the right to modify specifications without forewarning.

2. Controls

2.1 FRONT PANEL

The front panel provides a power switch, ten control buttons, and Vacuum Fluorescent Display (VFD).

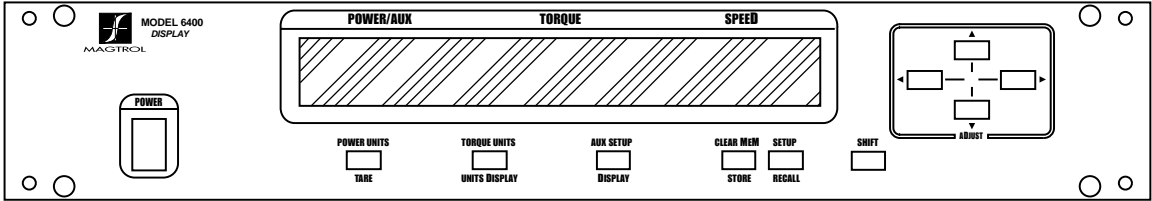

Figure 2-1 Front Panel

2.2 FRONT PANEL CONTROLS AND BUTTONS

The front panel controls and buttons, from left to right, are:

- Power switch
- Five double-function control buttons:

Primary Function	Secondary Function
TARE	POWER UNITS
UNITS DISPLAY	TORQUE UNITS
DISPLAY	AUX SETUP
STORE	CLEAR MEM
RECALL	SETUP

- SHIFT button (enables secondary functions printed in blue above control buttons)
- Four ADJUST buttons:
 - Left Arrow ◀
 - Right Arrow ▶
 - Up Arrow ▲
 - Down Arrow ▼

2.2.1 ENABLING SECONDARY FUNCTIONS

To enable the secondary function of the double-function control buttons:

1. Press and release the blue SHIFT button. The word “SHIFT” appears in the display.
2. Press any control button to enable the function shown in blue letters above the button (POWER UNITS, TORQUE UNITS, AUX SETUP, CLEAR MEM or SETUP).
3. Press and release the SHIFT button to exit the secondary functions and return to the main menu.

2.2.2 USING FRONT PANEL CONTROLS AND BUTTONS**2.2.2.1 Controls/Single-Function Buttons**

Button	To Use	Function
POWER	Press I to turn power ON Press O to turn power OFF.	Turns power ON or OFF.
SHIFT	Press this button and release; then press desired control button.	Enables the function written in blue above control button.
UP ▲	Press.	Increases magnitude of change when selecting a numerical value, or scrolls up.
DOWN ▼	Press.	Decreases magnitude of change when selecting a numerical value, or scrolls down.
LEFT ◀	Press.	Moves cursor left.
RIGHT ▶	Press.	Moves cursor right.

2.2.2.2 Double-Function Buttons

Button	To Use	Function
POWER UNITS	Press SHIFT and release; then press this button.	Sets desired unit of power. Use UP ▲ and DOWN ▼ buttons to view options. Press SHIFT to enable option. <i>See Section 4.1.1 – Power Units Setup</i>
TARE	Press.	Sets tare. <i>See Section 4.3 – Tare Function</i>
TORQUE UNITS	Press SHIFT and release; then press this button.	Sets desired unit of measure. Use UP ▲ and DOWN ▼ buttons to view options. Press SHIFT to enable option. <i>See Section 4.1.2 – Torque Units Setup</i>
UNITS DISPLAY	Press and hold.	Displays power unit and torque unit selections.
AUX SETUP	Press SHIFT and release; then press this button.	Sets the scaling of the auxiliary input. <i>See Section 4.1.4 – Auxiliary Input Setup</i>
DISPLAY	Press.	When in the PASS/FAIL mode, displays actual value of parameter.
CLEAR MEM	Press SHIFT and release; then press this button.	Clears the data memory. Resets next memory location to 0 (zero). <i>See Section 4.2.4 – Clearing the Memory</i>
STORE	Press.	Stores data into next available memory location. <i>See Section 4.2.1 – Storing Data Points</i>
SETUP	Press SHIFT and release; then press this button.	Accesses SYSTEM, PASS/FAIL and I/O parameter setup. <i>See Sections 4.1.3, 4.1.5 and 4.1.6</i>
RECALL	Press.	Displays memory contents beginning at last stored value. <i>See Section 4.2.2 – Recalling Data Points</i>

2.3 VACUUM FLUORESCENT DISPLAY (VFD)

The VFD provides information about the control functions, the torque transducer, and an auxiliary input device (if connected). The displays, from left to right, are:

- POWER (expressed in horsepower, kilowatts or watts) or AUX INPUT (expressed in scale factor times the auxiliary input voltage).
- TORQUE
- SPEED
- Memory Indicator
- Overload Indicator (If the inputs exceed the range of the instrument, "-OL-" will appear in the TORQUE or SPEED portion of the display. Once the condition has cleared, the unit will automatically return to the main menu.)

2.3.1 CONTRAST SETTINGS

The 6400 is shipped with the Contrast programmed to the lowest setting in order to prolong display life. If it is necessary to increase the Contrast for improved readability, execute the following steps:

1. Press and release SHIFT.
2. Press and release SETUP.
3. Press and release UP ▲ button twice. "Menu: I/O" appears in the display.
4. Press and release SHIFT. The display appears as follows:

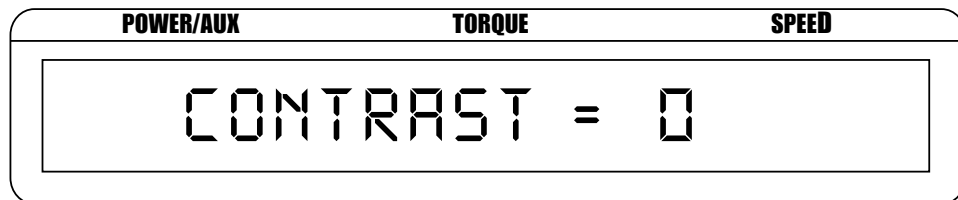

Figure 2–2 Contrast Setup Menu

5. Use UP ▲ and DOWN ▼ buttons until desired brightness is reached (select from a range of 0 to 3).
6. Press SHIFT three times to return to main menu.



Note: The lowest possible setting should be used to achieve desired result. Using a setting higher than necessary may cause display segments to burn-in over a period of time, resulting in uneven illumination from segment to segment.

2.4 REAR PANEL

The rear panel provides connectors and receptacles for connecting to appropriate equipment.

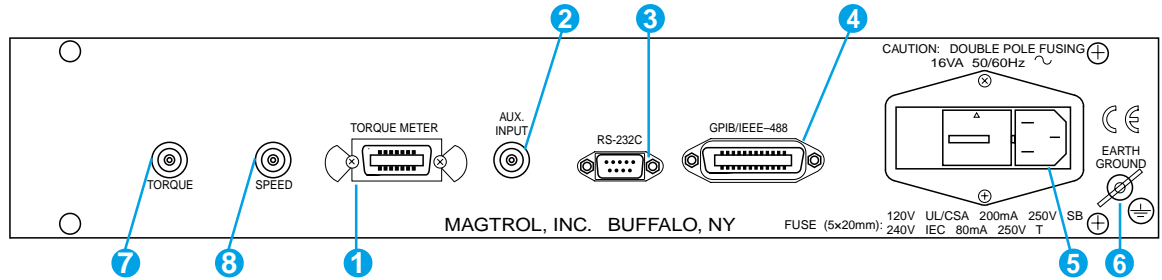
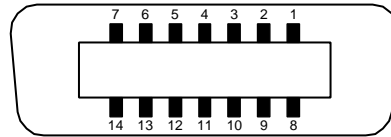

Figure 2-3 Rear Panel

2.5 REAR PANEL INPUTS AND OUTPUTS

- 1 TORQUE METER CONNECTOR Connect torque meter signal cable here.



- | | |
|----------------|-------------------------|
| 1. N/C | 8. N/C |
| 2. N/C | 9. ROTATIONAL DIRECTION |
| 3. +24 VDC | 10. SPEED |
| 4. +24 VDC COM | 11. N/C |
| 5. +24 VDC COM | 12. BITE |
| 6. N/C | 13. TORQUE COMMON |
| 7. N/C | 14. TORQUE SIGNAL |

Figure 2-4 Torque Meter Connector

- 2 AUX INPUT Connect auxiliary instrument cable here.

- 3 RS-232C Use this socket for RS-232 connector cable.

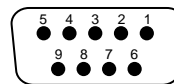

- | | |
|--------|----|
| 1. | 6. |
| 2. RX | 7. |
| 3. TX | 8. |
| 4. | 9. |
| 5. GND | |

Figure 2-5 RS-232C Interface

4 GPIB/
IEEE-488

Use this socket for GPIB cable (meets IEEE-488 specifications).

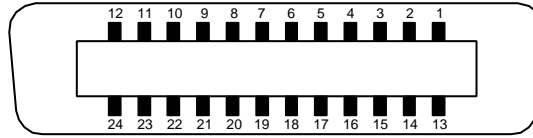

- | | |
|------------|-------------------|
| 1. D1 | 13. D5 |
| 2. D2 | 14. D6 |
| 3. D3 | 15. D7 |
| 4. D4 | 16. D8 |
| 5. E01 | 17. REN |
| 6. DAV | 18. DAV-COM |
| 7. NRFD | 19. NRFD-COM |
| 8. NDAC | 20. NDAC-COM |
| 9. IFC | 21. IFC-COM |
| 10. SRQ | 22. SRQ-COM |
| 11. ATN | 23. ATN-COM |
| 12. SHIELD | 24. SIGNAL GROUND |

Figure 2-6 GPIB/IEEE-488 Interface

5 POWER

Attach power cord here.

6 EARTH
GROUND

Attach earth ground here.

7 TORQUE
OUTPUT

Connect to data acquisition system here.

8 SPEED
OUTPUT

Connect to data acquisition system here.

3. Installation/Configuration



Note: Before installing the 6400, you should become familiar with the front and rear panels, as outlined in *Chapter 2—Controls*.

3.1 POWERING UP THE 6400



WARNING! TO REDUCE THE RISK OF ELECTRIC SHOCK, MAKE SURE THE 6400 IS EARTH GROUNDED BEFORE STARTING!

3.1.1 SETTING UNIT FOR LINE VOLTAGE

The 6400 will operate with either of the following power sources:

- 120 V 50/60 Hz
 - 240 V 50/60 Hz
1. Find the line cord receptacle on the rear panel. The line cord is a detachable NEMA Standard 3-wire.
 2. If changing the line voltage:
 - 1) Locate the power entry module.
 - 2) Remove the line cord.
 - 3) Insert a screwdriver into the slot and open the fuse door.
 - 4) Install the appropriate fuses for that voltage as marked on the rear panel of the unit.

3.1.2 SELF-TEST



Note: To make sure that the 6400 is operational, a Magtrol torque sensor must be installed and connected to the 6400. It is not required that the 6400 be connected to a computer.

1. Connect the 6400 to the torque transducer using a 14-pin to 6-pin signal cable.

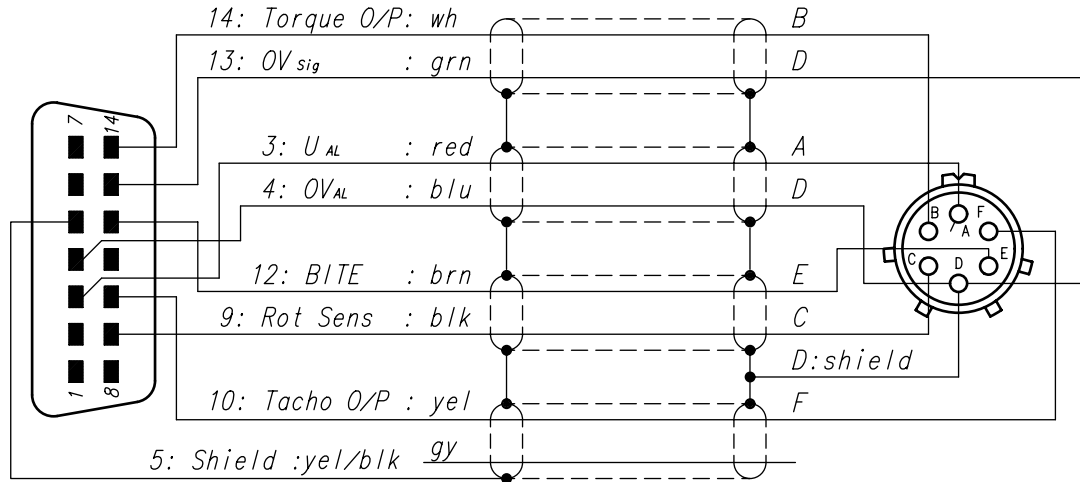

Figure 3-1 Cable and Connection Diagrams

2. Turn on the power to the 6400. The display panel will show all segments of the VFD (series of rectangles), indicating that the 6400 is downloading the program.

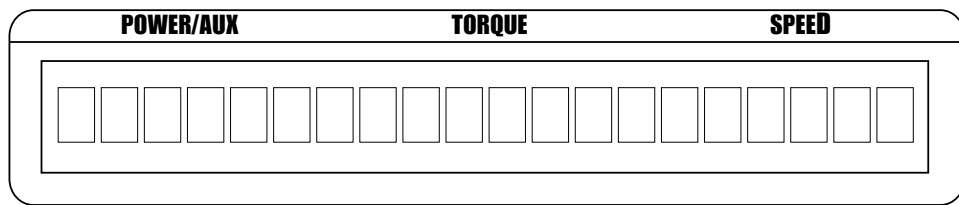

Figure 3-2 Program Download Display



Note: If the desired results did not occur, please see *Chapter 7 – Troubleshooting*.

When the program download is complete, the Title Display will appear.

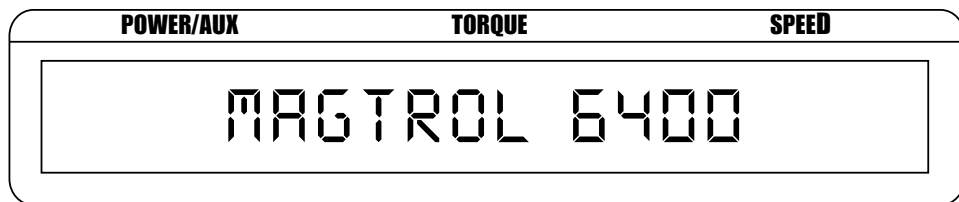

Figure 3-3 Title Display

Then an additional display will appear indicating the version of your Magtrol 6400 Torque Transducer Display.

SETUP

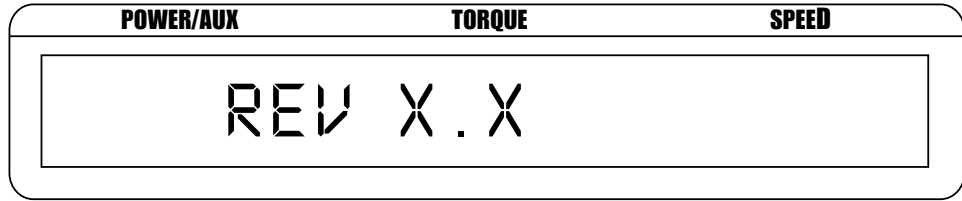

Figure 3–4 Revision Display

3.1.3 MAIN MENU

When the 6400 is completely powered up and ready for use, the Main Menu will appear on the display.

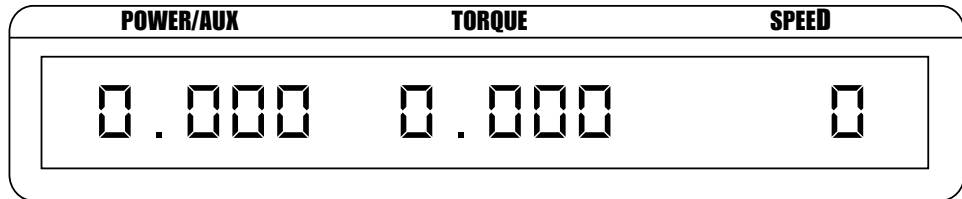

Figure 3–5 Main Menu

SETUP

4. Manually Controlled Operation



Note: Using the 6400 without a personal computer will limit its testing capabilities.

4.1 SETTING DESIRED OPERATING PARAMETERS



Note: See Appendix B: Front Panel/Display Menu Flow Charts.

4.1.1 POWER UNITS SETUP

Selects the desired unit of power (watts, hp, kW) that corresponds with the values displayed, or selects the auxiliary input (AUX) to be displayed.

1. Press and release SHIFT.
2. Press and release POWER UNITS button. The display appears as follows:

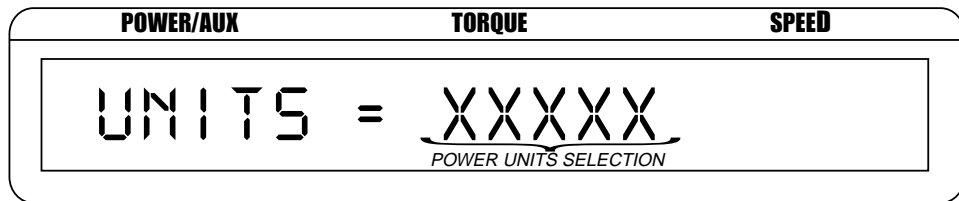

Figure 4-1 Power Units Setup Menu

3. Use UP ▲ and DOWN ▼ buttons until the desired unit of power is displayed.
4. Press and release SHIFT to make selection and return to main menu.

4.1.2 TORQUE UNITS SETUP

Selects the desired unit of measure (oz-in, oz-ft, lb-in, lb-ft, g-cm, kg-cm, Nmm, Ncm, Nm or kNm) that corresponds with the values displayed.

1. Press and release SHIFT.
2. Press and release TORQUE UNITS button. The display appears as follows:

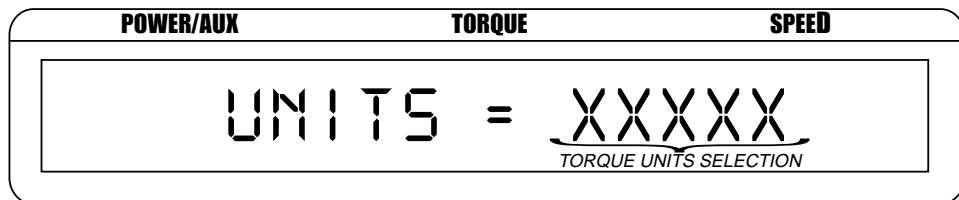

Figure 4-2 Torque Units Setup Menu

3. Use UP ▲ and DOWN ▼ buttons until the desired unit of measure is displayed.
4. Press and release SHIFT to make selection and return to main menu.

4.1.3 SYSTEM PARAMETER SETUP

Includes torque transducer selection, max power setup, direction input setup, as well as encoder and torque scale factor setup. The following steps will provide instructions for both a standard and custom torque transducer setup.

4.1.3.1 Standard Torque Transducer Setup

The basic system parameter setup for a standard torque transducer consists of three procedures, which must be performed in the following order:

1. Torque Transducer Selection
2. Max Power Setup
3. Direction Input Setup

Torque Transducer Selection

Selects the torque transducer model in use.

1. Press and release SHIFT.
2. Press and release SETUP button. "MENU: SYSTEM" appears in the display.
3. Press and release SHIFT. The Torque Transducer Selection Menu appears in the display.
4. Use UP ▲ and DOWN ▼ buttons until the torque transducer model being used appears in the display.

Max Power Setup

Sets the maximum power set point. Select from a range of 0.1 watts to 100,000 kilowatts.

1. Press and release SHIFT. The display appears as follows:

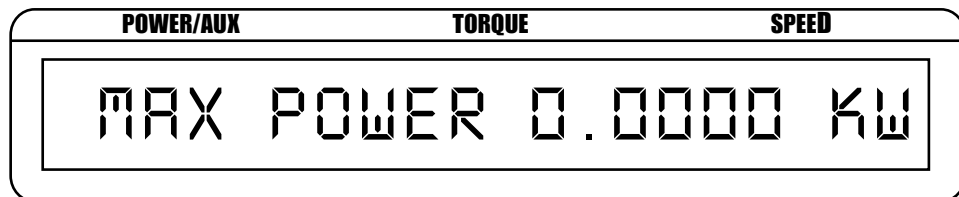

Figure 4-3 Max Power Setup Display

2. Use UP ▲, DOWN ▼, LEFT ◀ and RIGHT ▶ buttons to select the maximum power set point. The maximum power set point is used to indicate an overload condition. If the power reading exceeds what was programmed, the following message appears in the display:

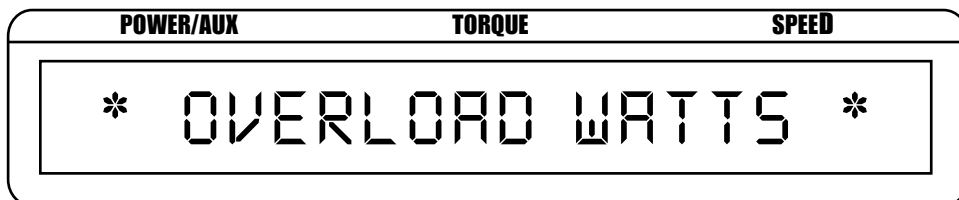

Figure 4-4 Power Overload Display

To clear an overload display, reduce speed and/or torque, then press and hold SHIFT. The unit will then return to the main menu.

Direction Input Setup

When the direction input function is enabled, it tells the 6400 to read the rotational sense bit from the torque transducer and displays that information in the SPEED portion of the display. A positive (+) reading indicates counterclockwise rotation while a negative (-) reading indicates clockwise rotation.

1. Press and release SHIFT. The display appears as follows:

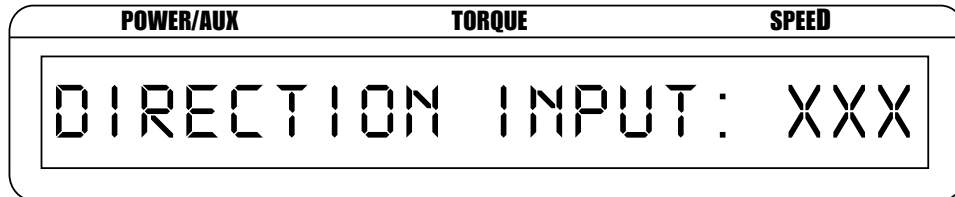

Figure 4-5 Direction Input Setup Menu

2. Use UP ▲ and DOWN ▼ buttons to turn direction input ON or OFF.
3. Press and release SHIFT to return to main menu.

4.1.3.2 Custom Torque Transducer Setup

The basic system parameter setup for a custom torque transducer consists of five procedures, which must be performed in the following order:

1. Torque Transducer Selection
2. Encoder Setup
3. Torque Scale Factor Setup
4. Max Power Setup
5. Direction Input Setup

Torque Transducer Selection

Selects the torque transducer model in use.

1. Press and release SHIFT.
2. Press and release SETUP button. "MENU: SYSTEM" appears in the display.
3. Press and release SHIFT. The Torque Transducer Selection Menu appears in the display.
4. Use UP ▲ and DOWN ▼ buttons until "TM SPECIAL" appears in the display.

Encoder Setup

Sets the number of pulses per revolution coming from the torque transducer. Select from a range of 1 to 10000. Default is 30.

1. Press and release SHIFT. The display appears as follows:

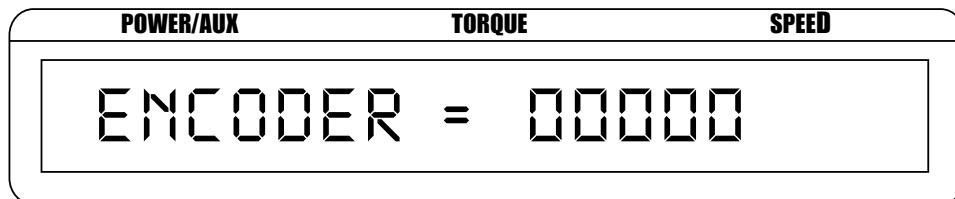

Figure 4-6 Encoder Setup Display

2. Use UP ▲, DOWN ▼, LEFT ◀ and RIGHT ▶ buttons to set encoder.

OPERATION

Torque Scale Factor Setup

Sets the full scale rating of the torque transducer being used. Select from a range of 0.0001 N / 5 volts to 100000 N / 5 volts.

1. Press and release SHIFT. The display appears as follows:

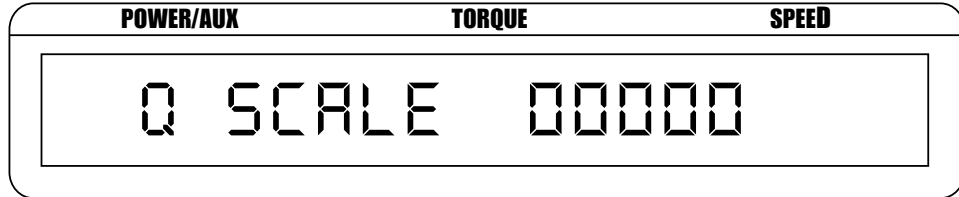

Figure 4-7 Torque Scale Factor Setup Display

2. Use UP ▲, DOWN ▼, LEFT ◀ and RIGHT ▶ buttons to set torque scale factor (Q SCALE).

Max Power Setup

Sets the maximum power set point. Select from a range of 0.1 watts to 100,000 kilowatts.

1. Press and release SHIFT. The Max Power Setup Display (as seen in *Figure 4-3*) appears.
2. Use UP ▲, DOWN ▼, LEFT ◀ and RIGHT ▶ buttons to select the maximum power set point. The maximum power set point is used to indicate an overload condition. If the power reading exceeds what was programmed, an OVERLOAD WATTS message appears in the display (as seen in *Figure 4-4 Power Overload Display*).

Direction Input Setup

When the direction input function is enabled, it tells the 6400 to read the rotational sense bit from the torque transducer and displays that information in the SPEED portion of the display. A positive (+) reading indicates counterclockwise rotation while a negative (-) reading indicates clockwise rotation.

1. Press and release SHIFT. The Direction Input Setup Menu (as seen in *Figure 4-5*) appears.
2. Use UP ▲ and DOWN ▼ buttons to turn direction input ON or OFF.
3. Press and release SHIFT to return to main menu.

4.1.4 AUXILIARY SCALE FACTOR SETUP

Sets the scale factor for auxiliary input. Select from a range of 0.0001 to 1000 units per volt. Default is 1 unit/volt.

1. Press and release SHIFT.
2. Press and release AUX SETUP button. The display appears as follows:

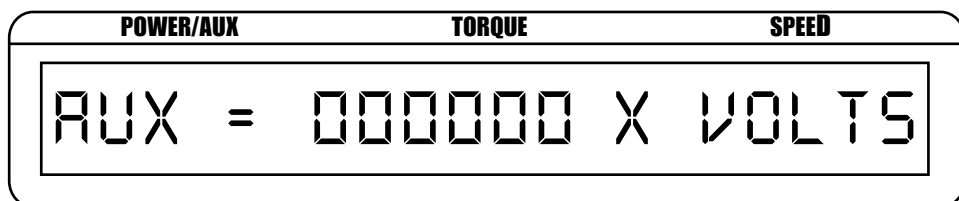

Figure 4-8 Auxiliary Scale Factor Setup Display

3. Use UP ▲, DOWN ▼, LEFT ◀ and RIGHT ▶ buttons to select value.
4. Press and release SHIFT to exit and return to main menu.

4.1.5 PASS/FAIL PARAMETER SETUP

Allows the user to set displayed pass/fail indication of torque, speed or auxiliary input.

1. Press and release SHIFT.
2. Press and release SETUP. "MENU: SYSTEM" appears in the display.
3. Press and release UP ▲ button. "MENU: PASS/FAIL" appears in the display.
4. Press and release SHIFT. The display appears as follows:

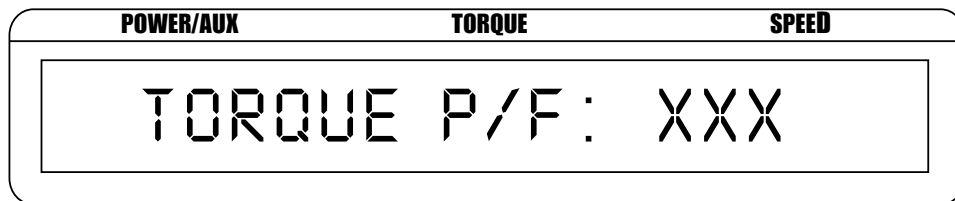

Figure 4-9 Torque Pass/Fail Setup Menu

5. Use UP ▲ and DOWN ▼ buttons to turn torque pass/fail testing ON or OFF.
6. If ON was selected, press and release SHIFT. The display appears as follows:

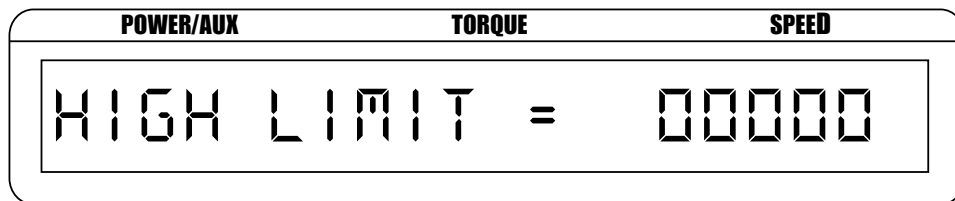

Figure 4-10 High Limit Setup Display

If OFF was selected, go to step 10.

7. Use UP ▲, DOWN ▼, LEFT ◀ and RIGHT ▶ buttons to select the high limit for torque. Select from a range of 0.0001 to 99999 displayed units.
8. Press and release SHIFT. The display appears as follows:

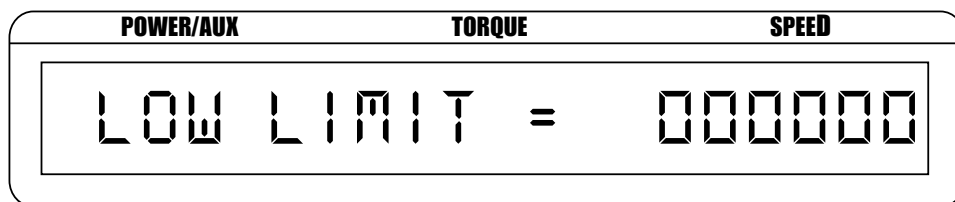

Figure 4-11 Low Limit Setup Display

9. Use UP ▲, DOWN ▼, LEFT ◀ and RIGHT ▶ buttons to select the low limit for torque. Select from a range of 0.0001 to 99999 displayed units.

OPERATION

10. Press and release SHIFT. The display appears as follows:

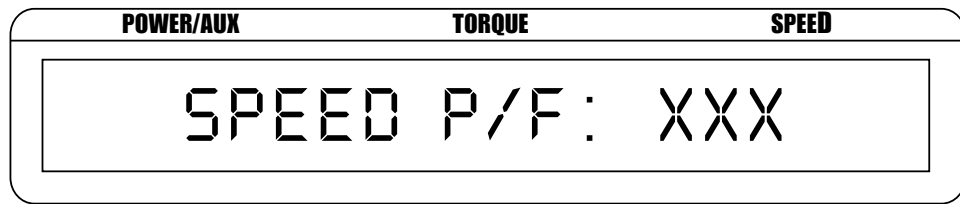

Figure 4-12 Speed Pass/Fail Setup Menu

11. Use UP ▲ and DOWN ▼ buttons to turn speed pass/fail testing ON or OFF.
12. If ON was selected, press and release SHIFT. The High Limit Setup Display (as seen in Figure 4-10) appears.
If OFF was selected, go to step 16.
13. Use UP ▲, DOWN ▼, LEFT ◀ and RIGHT ▶ buttons to select the high limit for speed. Select from a range of 0.0001 to 99999 rpm.
14. Press and release SHIFT. The Low Limit Setup Display (as seen in Figure 4-11) appears.
15. Use UP ▲, DOWN ▼, LEFT ◀ and RIGHT ▶ buttons to select the low limit for speed. Select from a range of 0.0001 to 99999 rpm.
16. Press and release SHIFT. The display appears as follows:

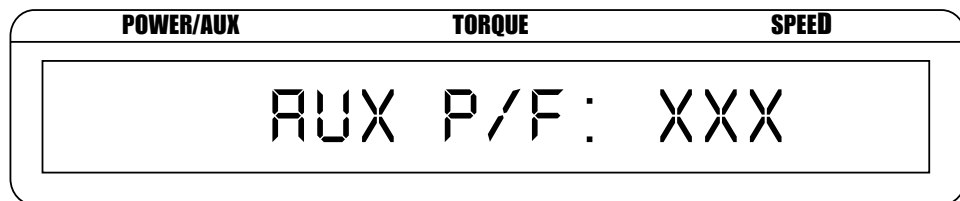

Figure 4-13 Auxiliary Input Pass/Fail Setup Menu

17. Use UP ▲ and DOWN ▼ buttons to turn auxiliary input pass/fail testing ON or OFF.
18. If ON was selected, press and release SHIFT. The High Limit Setup Display (as seen in Figure 4-9) appears.
If OFF was selected, go to step 22.
19. Use UP ▲, DOWN ▼, LEFT ◀ and RIGHT ▶ buttons to select the high limit for auxiliary input. Select from a range of -99999 to 99999.
20. Press and release SHIFT. The Low Limit Setup Display (as seen in Figure 4-11) appears.
21. Use UP ▲, DOWN ▼, LEFT ◀ and RIGHT ▶ buttons to select the low limit for auxiliary input. Select from a range of -99999 to 99999.
22. Press and release SHIFT to exit. Any pass/fail functions that were enabled will appear in the display as PASS or FAIL.

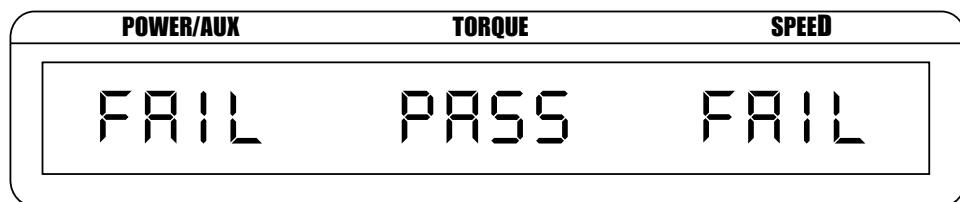

Figure 4-14 Pass/Fail Display Example

4.1.6 INPUT/OUTPUT (I/O) PARAMETER SETUP

Sets up GPIB (IEEE-488) address, serial (RS-232) baud rate and display contrast.

1. Press and release SHIFT.
2. Press and release SETUP. "MENU: SYSTEM" appears in the display.
3. Press and release UP ▲ button twice. "MENU: I/O appears in the display.
4. Press and release SHIFT. The Contrast Setup Menu (as seen in *Figure 2–2*) appears.
5. Use UP ▲ and DOWN ▼ buttons until desired contrast level is displayed.
6. Press and release SHIFT. The display appears as follows:

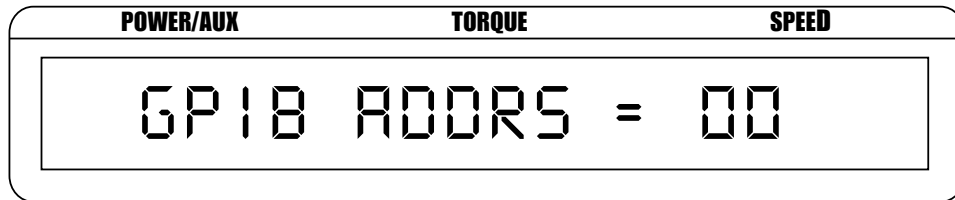

Figure 4–15 GPIB Address Setup Menu

7. Use UP ▲ and DOWN ▼ buttons until desired GPIB address is displayed. Select from a range of 0 to 15.
8. Press and release SHIFT . The display appears as follows:

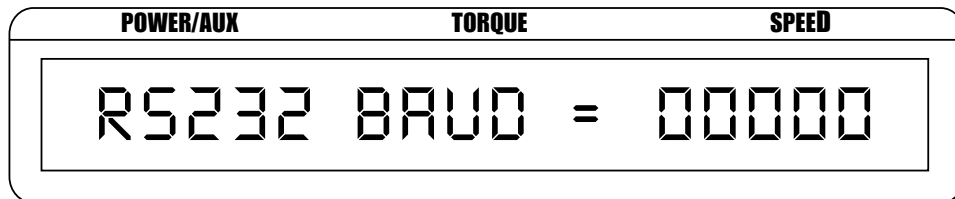

Figure 4–16 RS-232 Baud Rate Setup Menu

9. Use UP ▲ and DOWN ▼ buttons until desired RS-232 baud rate is displayed. Select from 300, 600, 1200, 2400, 4800, 9600 and 19200.
10. Press and release SHIFT to exit and return to main menu.

4.2 USING INTERNAL MEMORY

4.2.1 STORING DATA POINTS

1. Press and release STORE button. The display will indicate STORE followed by a number.

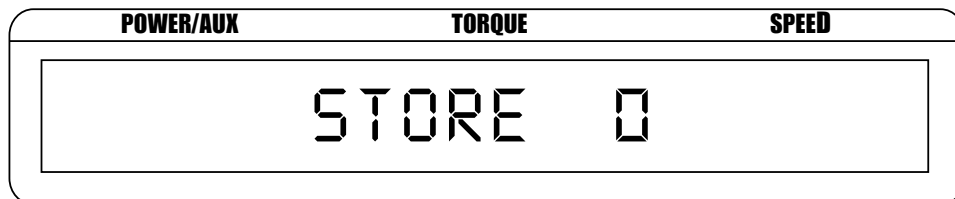

Figure 4–17 Store Display

This display indicates the memory location that contains the data.

OPERATION

2. Continue pressing STORE at each desired point.

4.2.2 RECALLING DATA POINTS

1. Press and release RECALL button. The display will indicate RECALL followed by a number.

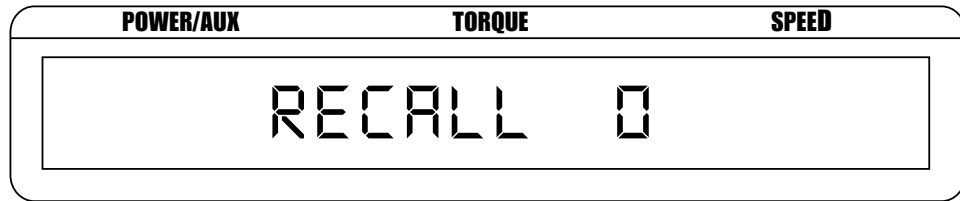

Figure 4-18 Recall Display

This number indicates the memory location that is being displayed. The order of recalled data is LAST IN = FIRST OUT (LIFO). An "M" also appears to the right of the SPEED display to let the user know that the displayed data is from memory and not real time data.



Figure 4-19 Main Menu with Recall Function Enabled

2. Use UP ▲ and DOWN ▼ buttons until desired data is retrieved.

4.2.3 EXITING THE MEMORY MODE

1. Press and release SHIFT.

4.2.4 CLEARING THE MEMORY

1. Press and release SHIFT.
2. Press and release CLEAR MEM button. "CLEAR MEMORY" will flash in the display and then return automatically to the main menu.

4.3. USING THE TARE FUNCTION

The calibrated offset of the 6400 may be changed using the tare function.

To set:

1. Press TARE.
2. Screen will flash "TARE SET" and the unit will take the current value of the inputs and make them the new zero.



Note: In order to reset the tare value, the power to the unit must be turned OFF.

4.4 SYSTEM TEST

Built-In Test Equipment (BITE) has been programmed into the 6400 in order to test the system and make sure all devices are connected and running properly. To activate:

1. Press and release SHIFT.
2. Press and release UP ▲ button. This sets the BITE line voltage to zero. The torque transducer will output 5.000 volts and the display will show full-scale torque of the transducer for approximately 10 seconds.

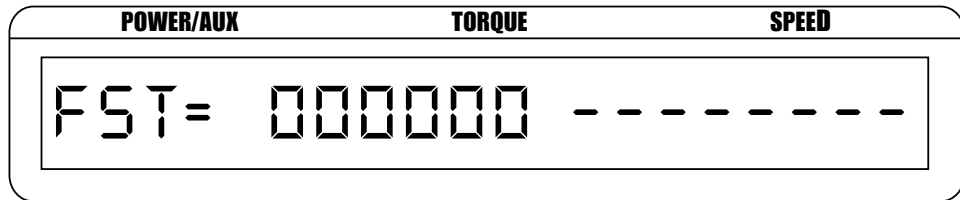

Figure 4–20 Torque Transducer at Full Scale

5. Computer Controlled Operation

The 6400 can be used with a personal computer (PC) to acquire and log data. Using the 6400 with a computer enables the unit to perform at its full capacity.

5.1 ABOUT THE GPIB INTERFACE

Magtrol prefers the GPIB (General Purpose Interface Bus)/IEEE-488 Standard for computer-to-instrument interfacing because:

- The GPIB parallel interface is faster than serial interfaces.
- The GPIB enables testers to access up to 15 instruments on one port. Because typical motor testing requires that at least five separate parameters be synchronized, a system of easy, fast access to more than one instrument is essential.
- The GPIB has rigid data formatting and hardware standards. These standards help to ensure that all functions will work properly when the hardware and software are installed.



Note: The GPIB interface is not standard on most computers. An interface card and driver software must be installed. An IEEE-488 cable must also be installed between the computer and the 6400. Magtrol recommends National Instruments Corporation hardware and software.

5.1.1 CONNECTING THE GPIB (IEEE-488) CABLE



CAUTION: MAKE SURE BOTH THE COMPUTER AND 6400 ARE TURNED OFF BEFORE INSTALLING THE GPIB CONNECTOR CABLE.

1. Connect one end of a high-quality, double-shielded cable to the 6400 GPIB connector.
2. Connect the other end to the GPIB interface in your personal computer.

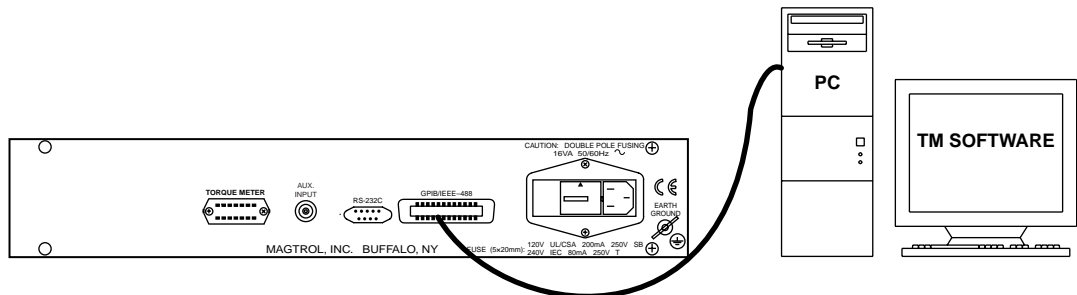

Figure 5-1 GPIB Installation

5.1.2 CHANGING THE GPIB PRIMARY ADDRESS

Each instrument serviced by the GPIB has its own primary address code, which enables the computer to obtain readings from the instrument. The factory default of the setting on the 6400 is 11.

Some personal computer interfaces can access from one to fifteen 4-bit primary addresses. Other interfaces can access as many as thirty-one 5-bit primary addresses. The 6400 uses the 4-bit format. For setup, follow the steps below.

1. Press and release SHIFT.
2. Press and release SETUP . "MENU: SYSTEM" appears in the display.
3. Press and release UP ▲ button twice. "MENU: I/O" appears in the display.
4. Press and release SHIFT twice. The GPIB Address Setup Menu (as seen in *Figure 4–15*) appears in the display.
5. Use UP ▲ and DOWN ▼ buttons until desired primary address is reached (range: 0 to 15).
6. Press and release SHIFT twice to return to main menu

5.2 ABOUT THE RS-232 INTERFACE

The 6400 is equipped with an RS-232 (serial) interface that communicates with the host computer through a DB-9 interface connector. The connector pin-out consists of 2-RX, 3-TX and 5-GND.

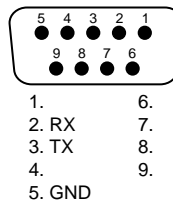

Figure 5–2 RS-232 Interface

5.2.1 CONNECTION

The RS-232 requires null modem wiring. To install use a null modem connector cable, which can be purchased from your local electronics store.

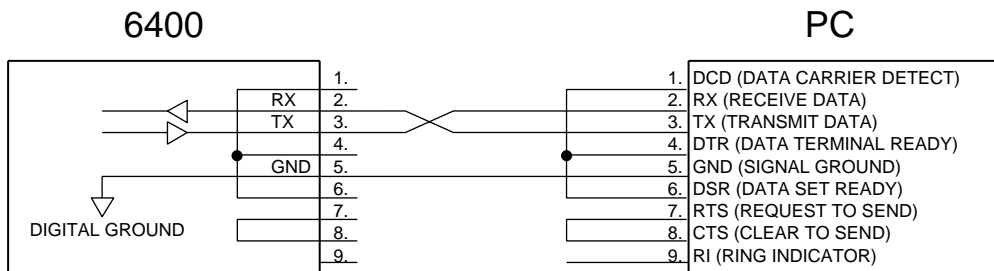

Figure 5–3 Cable Connection Using Null Modem

OPERATION

5.2.2 COMMUNICATION PARAMETERS

- No parity
- 8 data bits
- 1 stop bit

5.2.3 BAUD RATE

There are several different baud rates to choose from including 300, 600, 1200, 2400, 4800, 9600 and 19200. To set up the desired baud rate, follow the instructions below.

1. Press and release SHIFT.
2. Press and release SETUP. "MENU: SYSTEM" appears in the display.
3. Press and release UP ▲ button twice. "MENU: I/O" appears in the display.
4. Press SHIFT three times. The RS-232 Baud Rate Setup Menu (as seen in *Figure 4-16*) appears in the display.
5. Use the UP ▲ and DOWN ▼ buttons until desired baud rate is reached.
6. Press and release SHIFT to make selection and return to main menu.

5.3 CHECKING THE 6400-TO-PC CONNECTION



Note: The 6400 and its host computer must be communicating before acquiring data.

1. Make sure the primary GPIB address is set correctly for the 6400.
2. Set the input variable to 16 characters (14 variable characters and the two required data termination characters CR and LF. See *Section 5.5 – Programming*.)
3. Issue output data command "OD" and read 15 characters according to the instructions for your GPIB interface or serial.

Desired Results

- Torque/speed data will be returned.
- The string does not return with a COMMAND ERROR CR-LF message.



Note: If the desired results did not occur, please see *Chapter 7 – Troubleshooting*.

5.4 DATA FORMAT

Speed-torque data is a fixed-length string in ASCII format with a floating point decimal. Use the following string format:

SddddTdddd.RX<cr><lf>

Or

SddddTdddd.LX<cr><lf>

Where...

- S = Speed in rpm. (No leading zeros are used.)
- d = Decimal digit 0 through 9.
- T = Torque in units selected during setup. (The torque value always contains a decimal point.)
- L = Counterclockwise dynamometer shaft rotation (left).
- R = Clockwise dynamometer shaft rotation (right).
- X = If the direction input is ON (enabled under system setup), a 0 will indicate counterclockwise rotation and a 1 will indicate clockwise rotation. If direction input is OFF, this character is undefined.
- . = Decimal point. (The decimal point location depends on the specific torque transducer and torque range in use.)



Note: The [cr] and [lf] characters will not display.

EXAMPLE

If a motor is running at 1725 rpm clockwise, with the torque transducer loading the motor to 22.6 oz·in, the 6400 will return:

S 1725T22.60L1

By manipulating the string, the speed-torque and shaft direction (if required) can be extracted. Then separate numerical variables can be assigned to them for data processing.

5.5 PROGRAMMING



Note: Check the manual provided with your software for full instructions.

5.5.1 DATA TERMINATION CHARACTERS

Use the following information to answer the formatting questions asked when installing your GPIB software. All GPIB data acquisition systems require the use of data termination characters. The 6400 uses the GPIB standard termination characters Carriage Return (CR) and Line Feed (LF). Provide them in that order.

5.5.1.1 Codes for CR - LF

	BASIC	HEX	DEC
CR =	CHR\$(13)	0D	13
LF =	CHR\$(10)	0A	10

5.4.2 TIMEOUT

Set the timeout for at least one second if asked to set a communication fault delay timeout.



Note: If the communication fault delay timeout is too short, or if the computer resets the interface too quickly, the host instrument may stop responding.

5.6 6400 COMMAND SET

When entering a command code:

1. Type all characters in uppercase ASCII format.
2. End all commands with a CR-LF (hex 0D-0A).
3. Do not string multiple commands together in one line.

The character # represents a floating-point numerical value following the command. Leading zeroes are not required.



Note: If a command is not recognized, a COMMAND ERROR CR-LF string return will occur accompanied by a beep.

5.6.1 COMMUNICATION COMMANDS

Command Code	Function	Explanation
IDN?	Inquire mode.	Response = "MAGTROL 6400 REV x.xx" IEEE-488.2 query
H	Sets high data acquisition rate (100 samples per second).	The Torque Transducer Display outputs data at 100 S/s (Using an RS-232 interface, the rate is 60 S/s.)
L	Sets low data acquisition rate (3.8 samples per second).	The Torque Transducer Display outputs data at 3.8 S/s (default rate).
OA	Prompts to return to auxiliary input data string.	"Output Auxiliary" prompt to return the value at the AUX INPUT × AUX SCALING factor.
OD	Prompts to return speed-torque-direction data string.	"Output Data" prompt to return data string with this format: <div style="text-align: center;"> SxxxxTxxxxRX<cr><lf> or SxxxxTxxxxLX<cr><lf> </div> R or L is the shaft direction indicator, where: L = left; clockwise (CW) R = right; counterclockwise (CCW) The speed will equal the displayed value and the torque will be in the same units as displayed on the front panel.

OPERATION

5.6.2 SETUP COMMANDS

Command Code	Function	Explanation
DR	Resets direction.	Torque signal provides \pm indication.
DS	Sets direction.	Use direction bit from transducer to indicate \pm torque (above 20 rpm).
M1	Enables front panel controls.	Use this command to enable front panel control of most functions.
MØ	Locks out front panel controls.	Use this command to lock out the front panel controls, so that the Torque Transducer Display settings can be changed only by using the computer with either the GPIB (IEEE-488) or the RS-232 interface.
R	Resets as follows: • Manual control ON • Low data acquisition rate • Tare OFF	Use this command to cancel any previous commands. Note: These settings are the power-on default settings.
TR	Resets Tare.	Resets tare to 0 (zero).
TS	Sets Tare.	Reads current torque and uses as tare value.
UA#	Sets auxiliary input scaling to #.	This command sets the scaling factor for the auxiliary input to # units/volt. The range is 0 to 10000. Programmed value # is not saved at power down.
UE#	Sets encoder units to # when using a UI14 command.	# = 0 to 1000
UI#	Selects model.	For hp and watts calculations to be correct, the correct torque transducer must be specified. Note: "TM" includes any of the TM Series Torque Transducers (TM, TMHS or TMB) Values for # are: 0 = TM 204, 1 Nm 8 = TM 212, 200 Nm 1 = TM 205, 2 Nm 9 = TM 213, 500 Nm 2 = TM 206, 5 Nm 10 = TM 214, 1000 Nm 3 = TM 207, 10 Nm 11 = TM 215, 2000 Nm 4 = TM 208, 20 Nm 12 = TM 216, 5000 Nm 5 = TM 209, 20 Nm 13 = TM 217, 10000 Nm 6 = TM 210, 50 Nm 14 = TM SPECIAL 7 = TM 211, 100 Nm Programmed value # is not saved at power down.
UR#	Sets display torque units to #.	Values for # are: 0 = oz·in 5 = kg·cm 1 = oz·ft 6 = Nmm 2 = lb·in 7 = Ncm 3 = lb·ft 8 = Nm 4 = g·cm 9 = kNm Torque unit conversion defaults to 0 (oz·in) if out of range. Programmed value # is not saved at power down.
UT#	Sets torque units to # when using a UI14 command.	# = 0 to 100,000

5.6.3 CALIBRATION COMMANDS

Command Code	Function	Explanation
CZT	Sets torque zero.	See <i>Chapter 6 - Calibration</i> .
CZA	Sets aux. zero.	See <i>Chapter 6 - Calibration</i> .
CFT	Sets torque gain.	See <i>Chapter 6 - Calibration</i> .
CFA	Sets aux. gain.	See <i>Chapter 6 - Calibration</i> .

6. Calibration

6.1 CLOSED-BOX CALIBRATION

The 6400 features closed-box calibration. The advantage of closed-box calibration is that the user does not have to disassemble the case or make mechanical adjustments.

The torque readout and auxiliary input can be calibrated using external reference sources. Correction factors for offset and gain are stored in nonvolatile memory. They remain in effect until the user or the calibration house updates them.

The front panel displays the actual values for the ZERO and GAIN correction factors. Record these values before calibration. In the unlikely event of a Torque Transducer Display failure, it can be re-initialized by pressing and holding the STORE and RECALL buttons while turning the power on. All internal memory and setups will be lost. After re-initializing, reprogram the GAIN and ZERO values into memory.

6.2 CALIBRATION SCHEDULE

Calibrate the 6400:

- After any repairs are performed.
- At least once a year; more frequently to ensure required accuracy.

6.3 BASIC CALIBRATION PROCESS

The basic calibration process consists of four procedures which must be performed in the following order:

1. Initial Procedure
2. Torque Offset and Gain (computer or manual)
3. Auxiliary Input Offset and Gain (computer or manual)

Items needed for calibrating the 6400:

- External voltage reference of 0 to 10 volts DC
- Digital multimeter (DMM)

Both instruments should have a VDC accuracy of 0.05% or better.

6.3.1 INITIAL CALIBRATION PROCEDURE

1. Allow the 6400 to stabilize in an environment with:
 - An ambient temperature of 18°C to 25°C.
 - Relative humidity less than 80%.
2. Turn on the 6400.
3. Allow the 6400 to warm up for at least 30 minutes.
4. Go to computer or manual calibration sections.

6.3.2 TORQUE OFFSET AND GAIN

6.3.2.1 Computer

1. Connect the external voltage reference common to pin 13 of the torque meter input connector.
2. Connect the external voltage reference high to pin 14 of the torque meter input connector.
3. Apply 0.000 VDC.
4. Send the “CZT” command.
5. Apply +10.000 VDC.
6. Send the “CFT” command.

6.3.2.2 Manual

1. Enable the calibration mode as follows:
 - 1.) Turn instrument power OFF.
 - 2.) Press and hold the LEFT ◀ and RIGHT ▶ buttons simultaneously while turning the instrument power ON. The software revision date appears on the display.

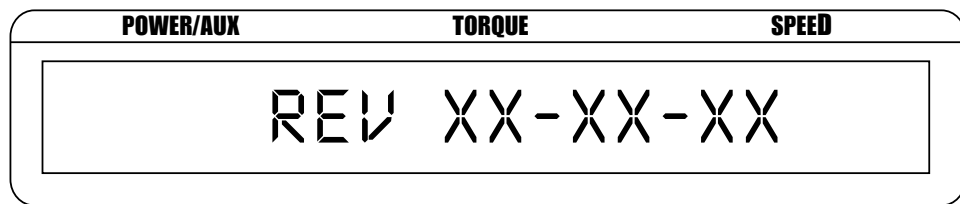

Figure 6-1 Software Revision Date Display

2. Press and release SHIFT. The display appears as follows:

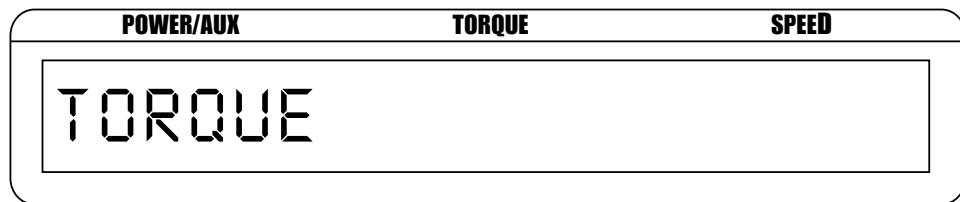

Figure 6-2 Torque Offset and Gain Display

3. Connect the external voltage reference common to pin 13 of the torque meter input connector.
4. Connect the external voltage reference high to pin 14 of the torque meter input connector.
5. Apply 0.000 VDC.
6. Press and release UNITS DISPLAY. The display appears as follows:



Figure 6-3 Zero Torque Display

7. Press and release SHIFT. The display appears as follows:

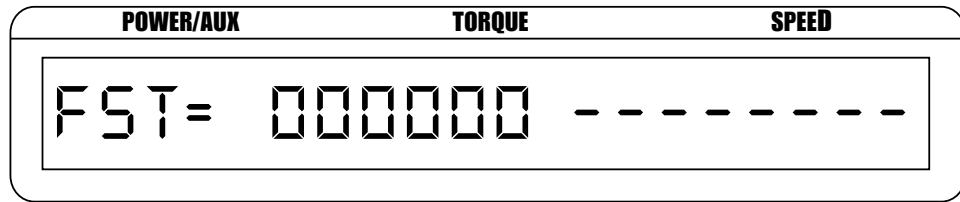

Figure 6-4 Full Scale Torque Display 1

8. Apply +10.000 VDC. The display appears as follows:

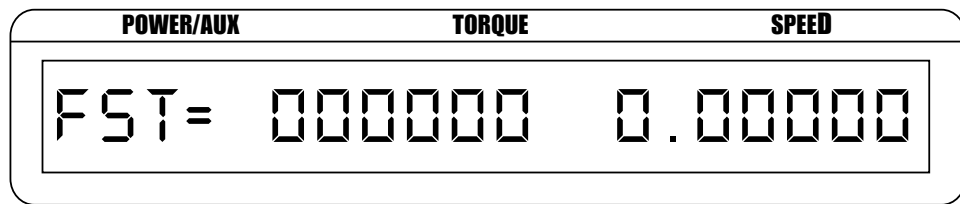

Figure 6-5 Full Scale Torque Display 2

9. Press and release SHIFT twice to exit calibration and return to main menu.



Note: To exit calibration mode without making any changes, press the SHIFT button twice.

6.3.3 AUXILIARY INPUT OFFSET AND GAIN

6.3.3.1 Computer

1. Connect the external voltage reference to the Auxiliary Input BNC connector.
2. Apply 0.000 VDC.
3. Send the CZA command.
4. Apply +10.000 VDC.
5. Send the CFA command.

6.3.3.2 Manual

1. Enable the calibration mode as follows:
 - 1.) Turn instrument power OFF.
 - 2.) Press and hold the LEFT ◀ and RIGHT ▶ buttons simultaneously while turning the instrument power ON. The software revision date appears on the display as shown in *Figure 6-1*.

- 2. Press and release SHIFT twice. The display appears as follows:

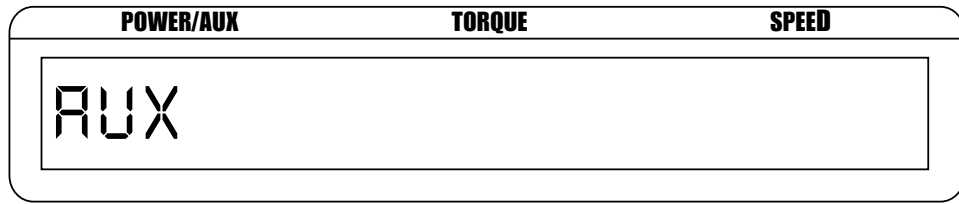

Figure 6-6 Auxiliary Offset and Gain Display

- 3. Connect the external voltage reference to the Auxiliary Input BNC connector.
- 4. Apply 0.000 VDC.
- 5. Press and release UNITS DISPLAY. The display appears as follows:



Figure 6-7 Zero Auxiliary Display

- 6. Press and release SHIFT. The display appears as follows:

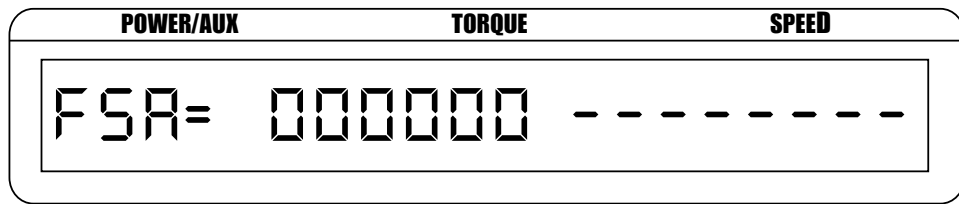

Figure 6-8 Full Scale Auxiliary Display 1

- 7. Apply +10.000 VDC. The display appears as follows:



Figure 6-9 Full Scale Auxiliary Display 2

- 8. Press and release SHIFT to exit calibration and return to the main menu.

MAINTENANCE

7. Troubleshooting

Problem	Reason	Solution
Returned data indicates COMMAND ERROR.	Command does not match the unit's programmed set of instructions.	Use correct command and format.
Mechanical power reads much higher or lower than expected.	Torque units or scale factor is incorrect.	Set torque input units and scale factor to match the specifications of torque transducer.
No GPIB communication.	Setup error and/or hardware fault.	Check: <ul style="list-style-type: none"> • GPIB address of Torque Transducer Display. • GPIB cable: should be functioning and attached to Torque Transducer Display and computer interface card
No RS-232 communication.	Setup error and/or hardware fault.	Check: <ul style="list-style-type: none"> • Baud rate of Torque Transducer Display • Pinout of serial cable • Cable attachment to Torque Transducer Display and serial interface port of computer

If you require additional assistance, please contact Magtrol Customer Service at 1-716-668-5555.

Appendix A: LabVIEW Programming Examples

Shown is an example of communicating with the 6400 when writing your own software.

A.1 SIMPLE READ

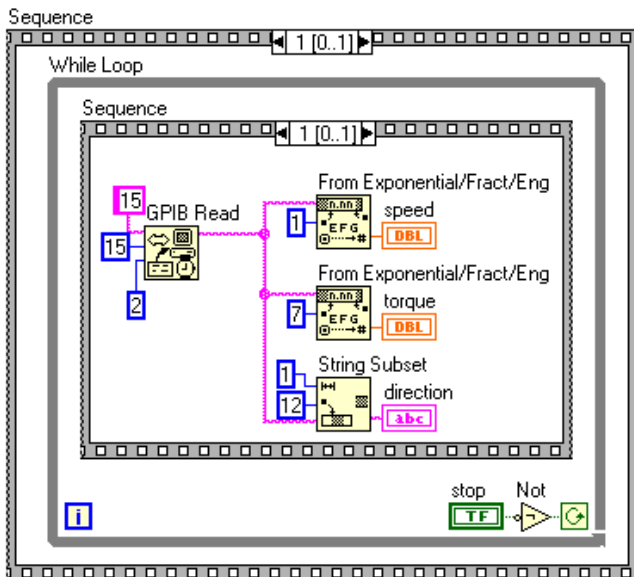
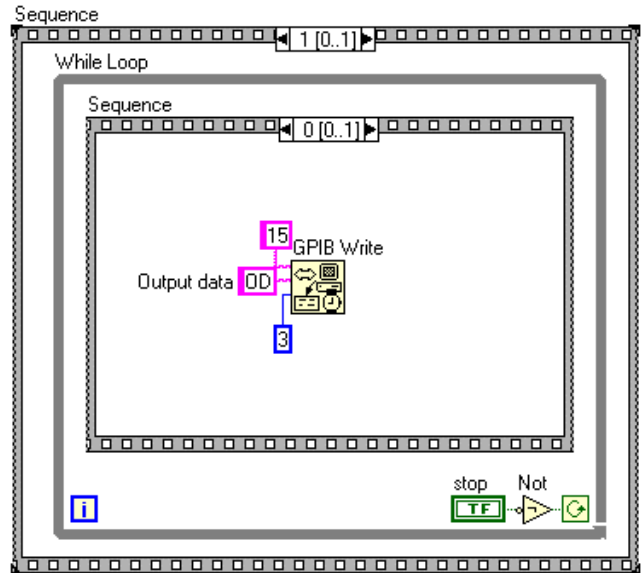
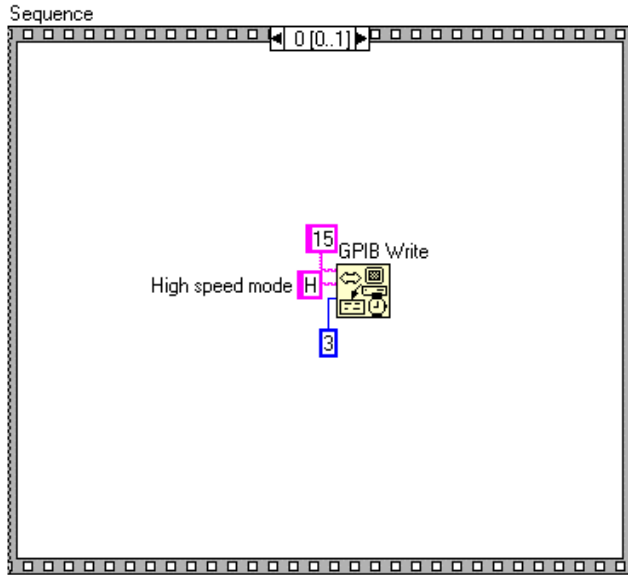

Appendix B: Front Panel/Display Menu Flow Charts

B.1 SETUP MENU

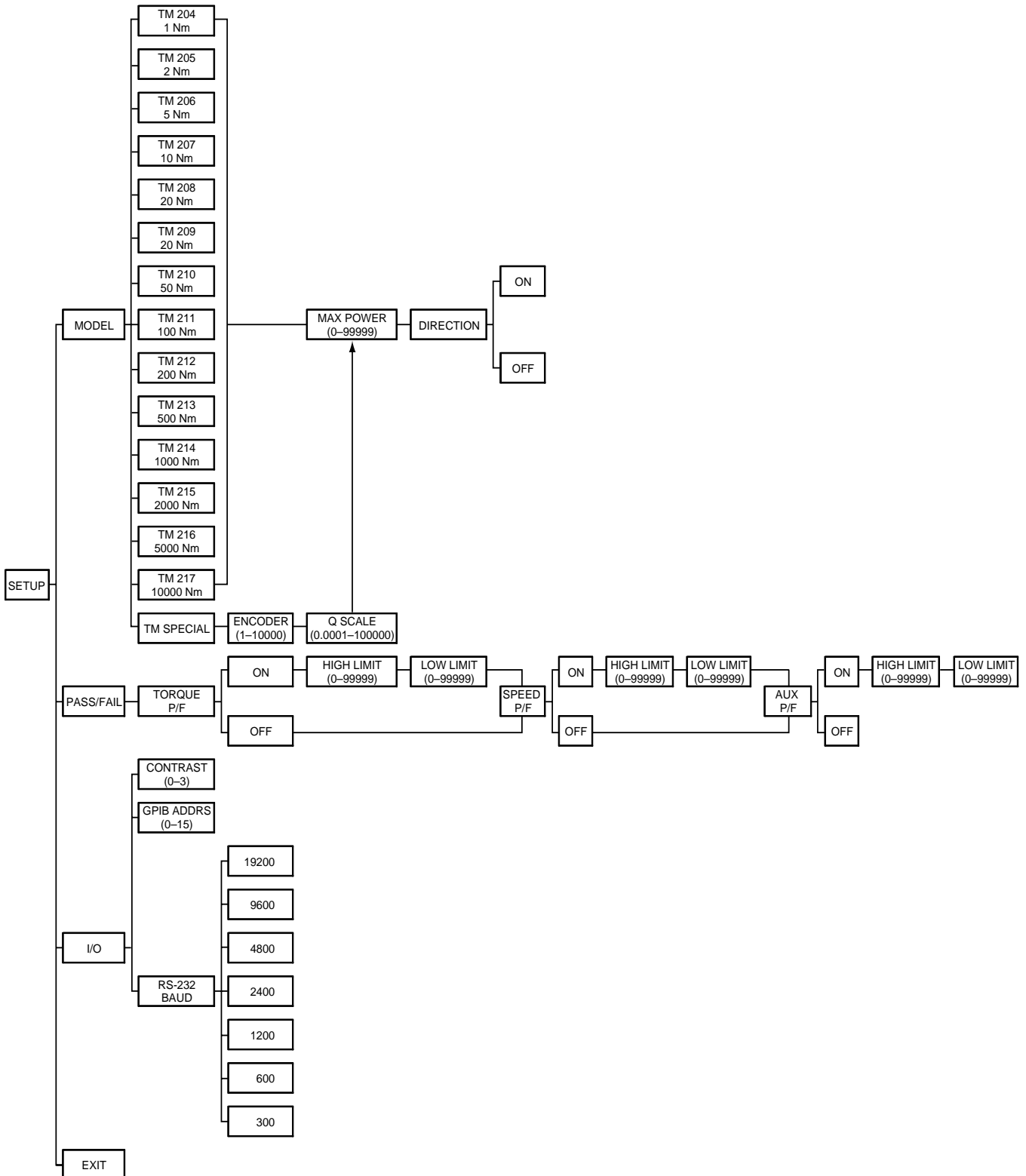

B.2 TORQUE UNITS MENU

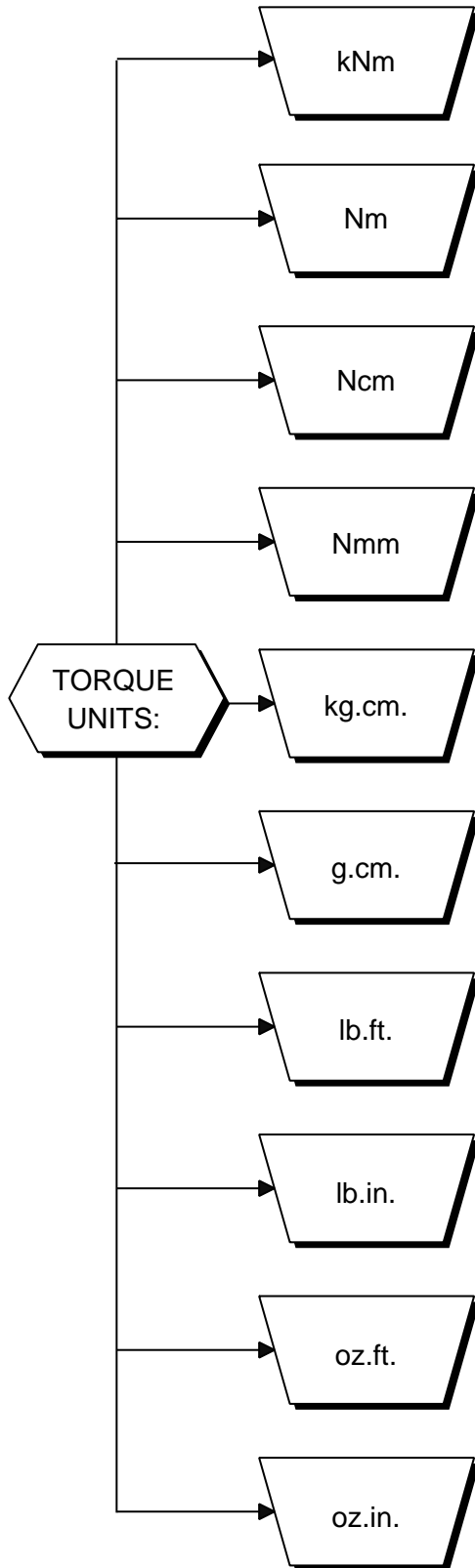

B.3 AUX SETUP MENU



B.4 POWER UNITS MENU

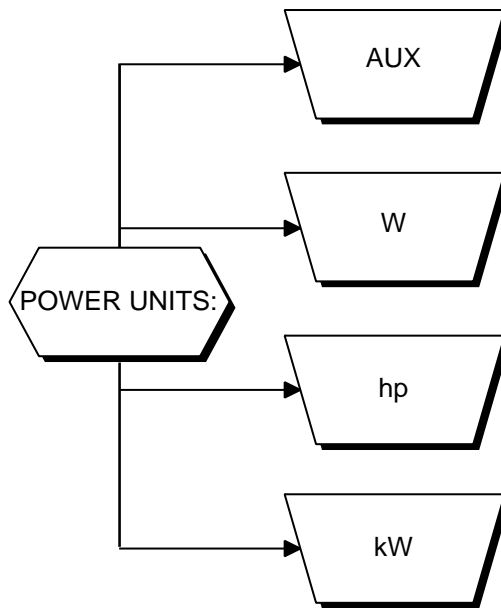

Appendix C: Schematics

C.1 ANALOG SECTION

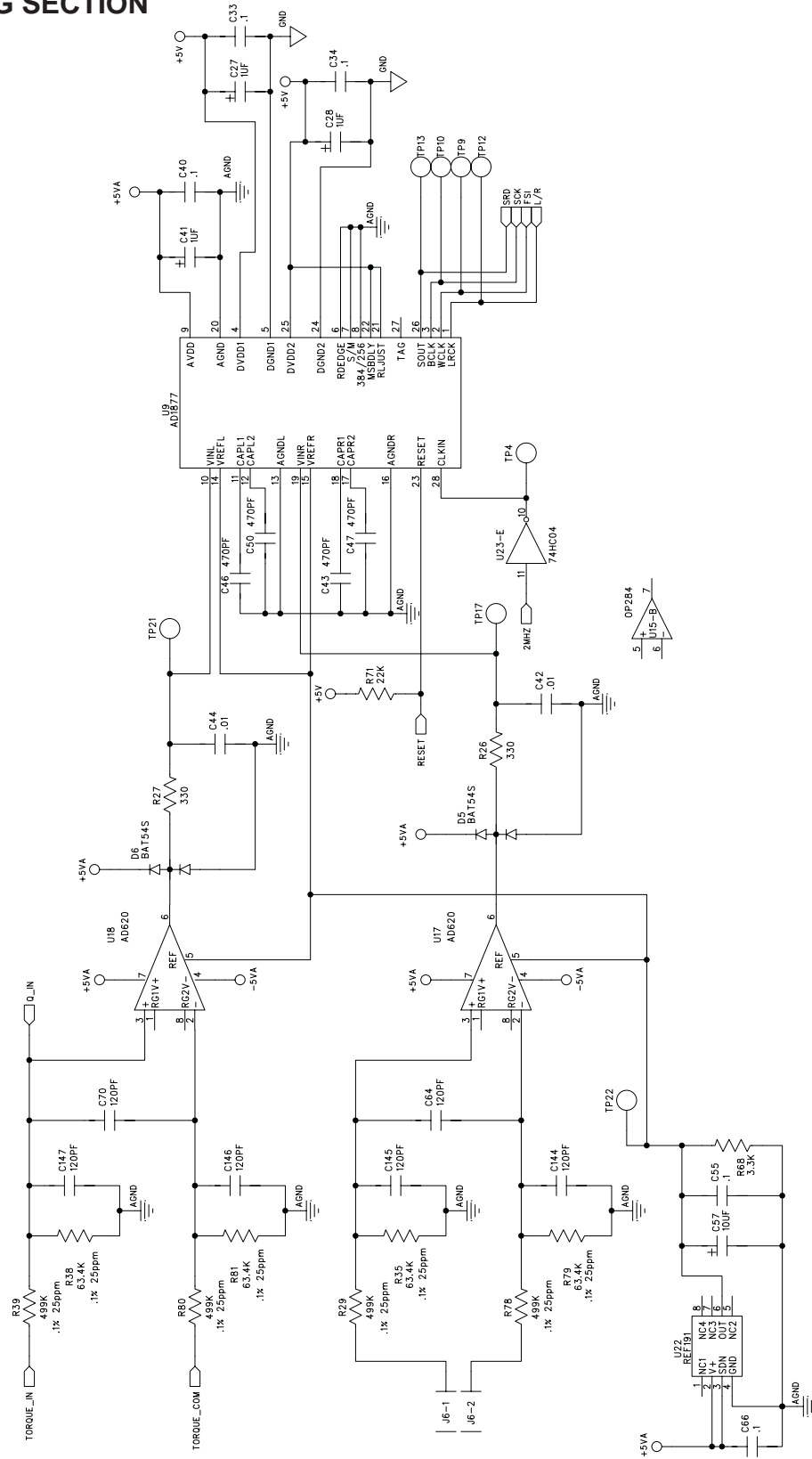

C.2 CPU SECTION

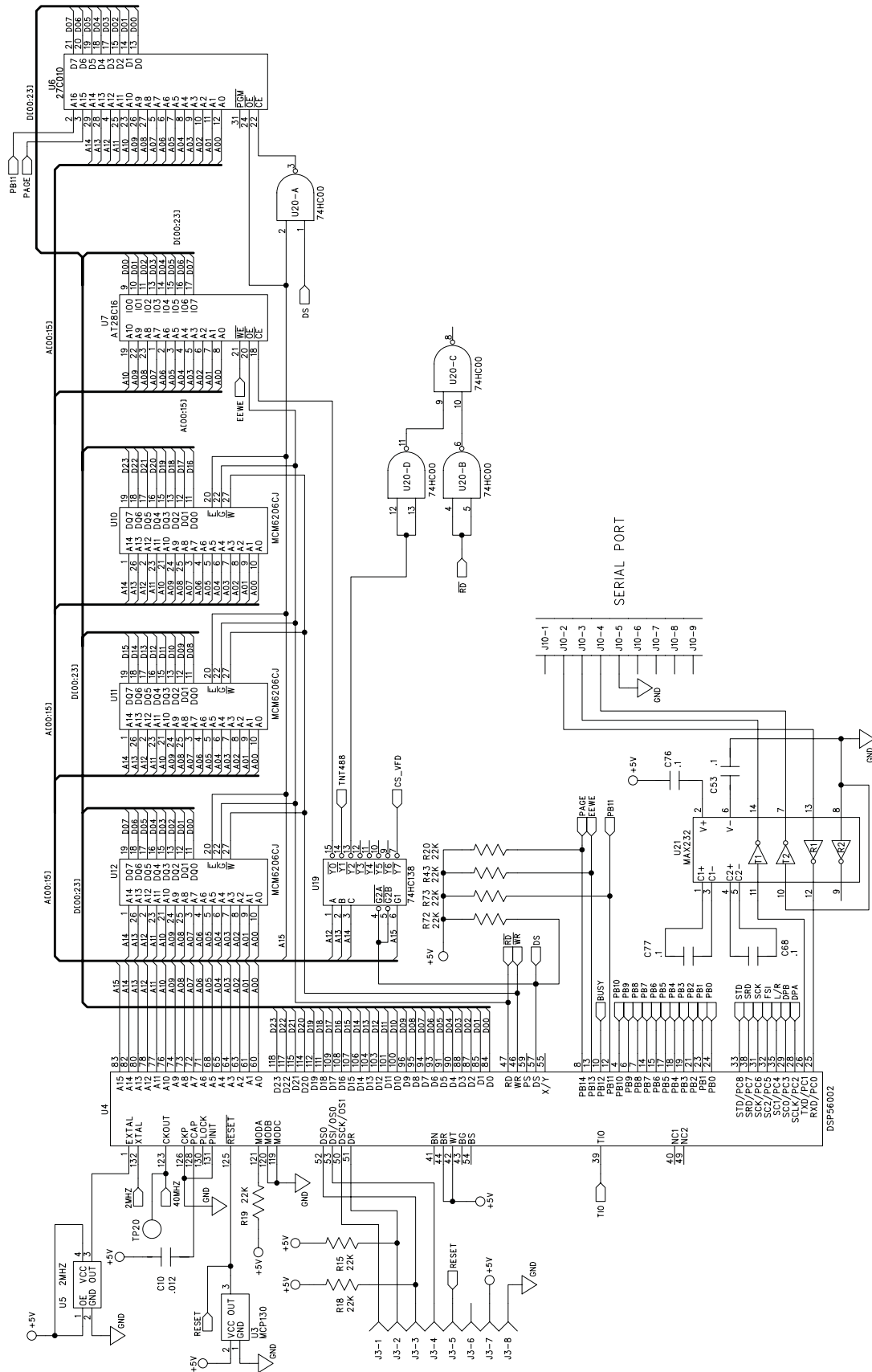

C.3 INPUT/OUTPUT (I/O) SECTION

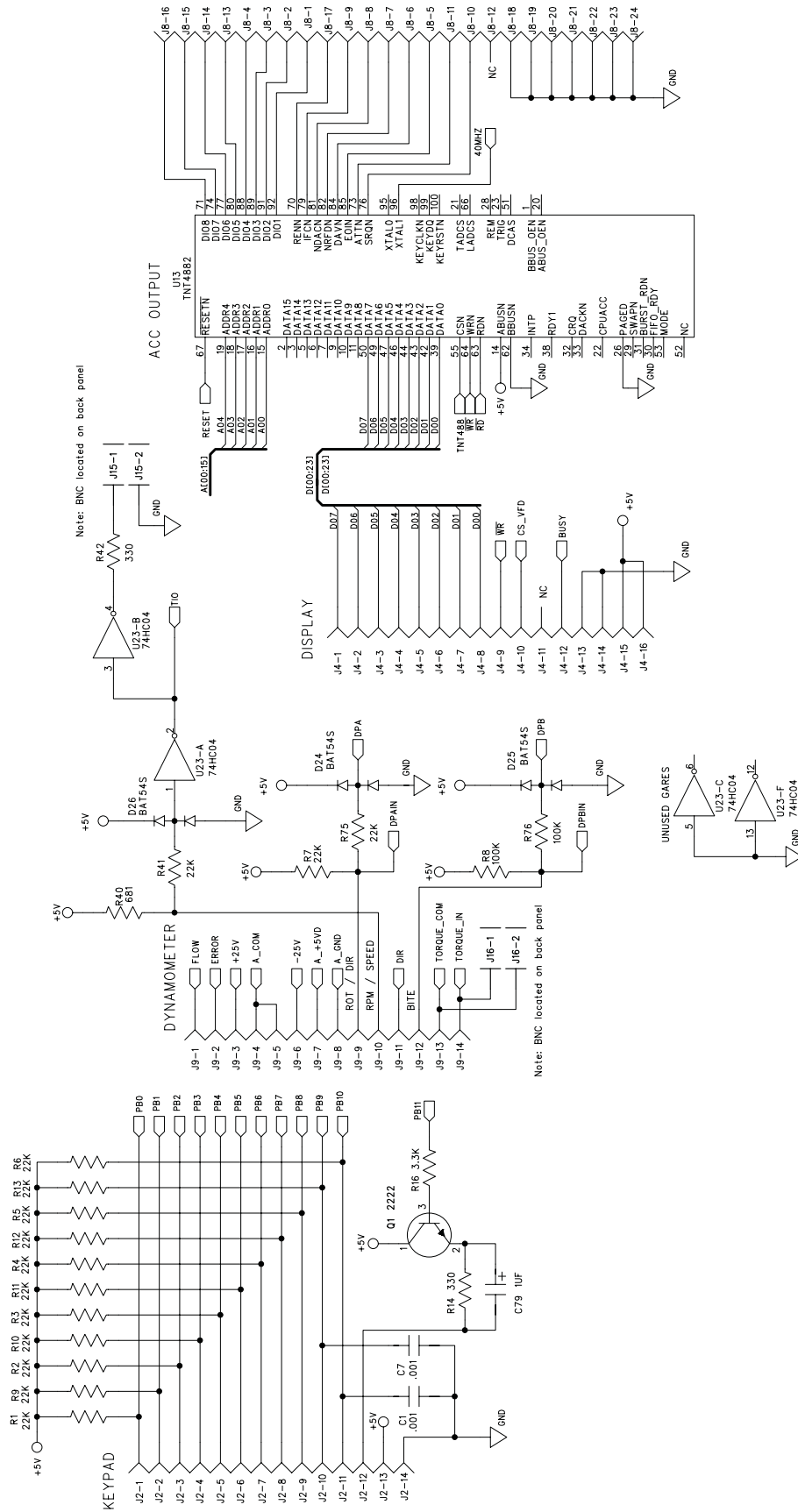

C.4 POWER SUPPLY SECTION

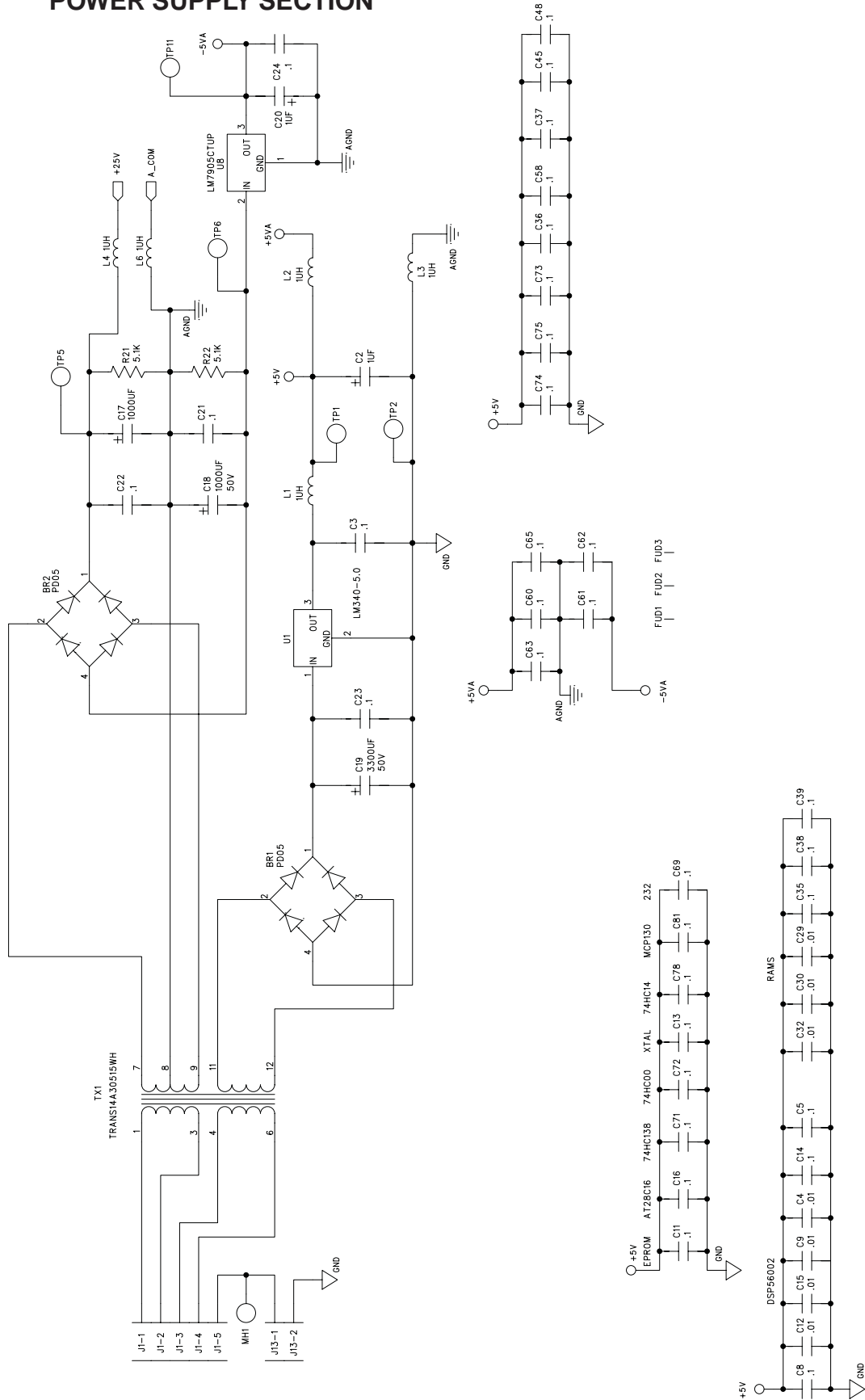

C.5 KEYPAD

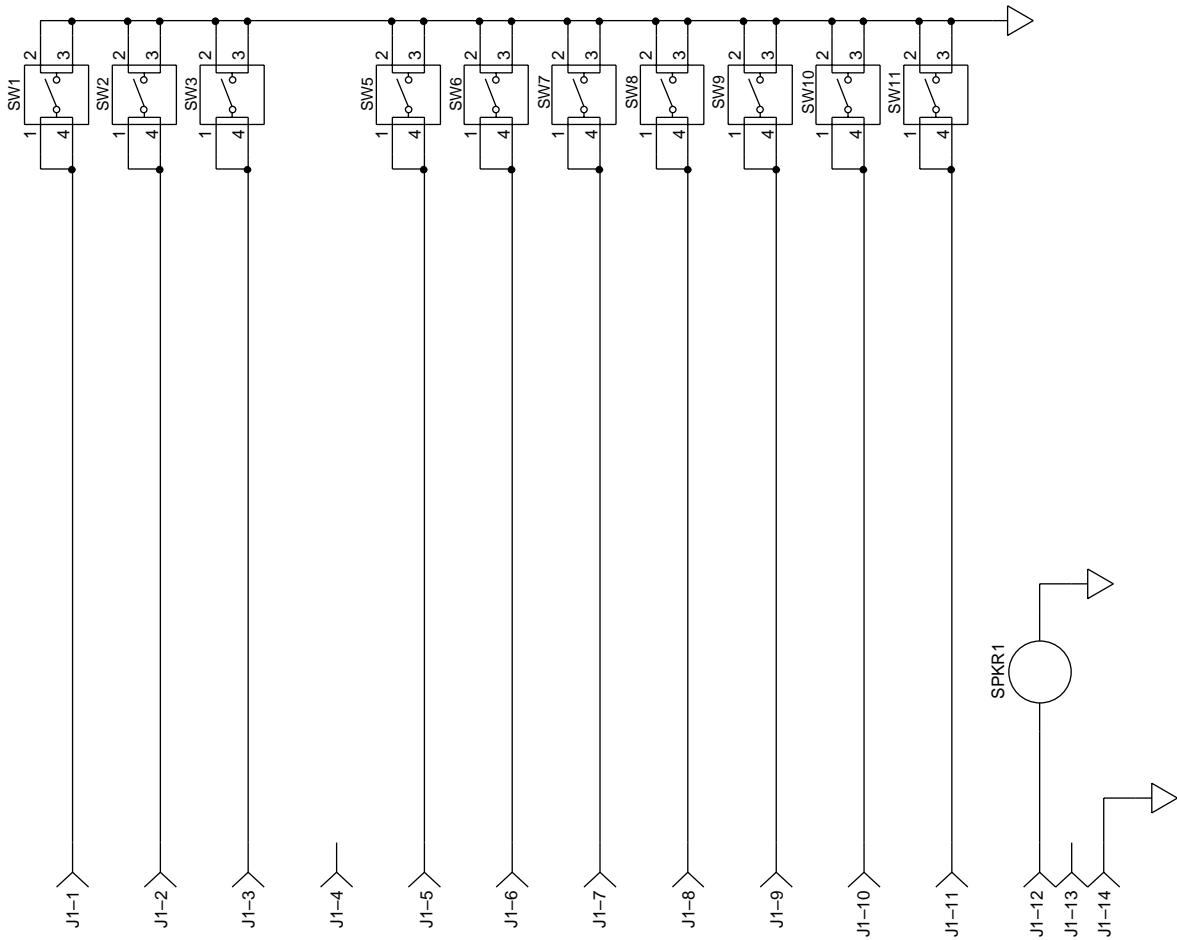
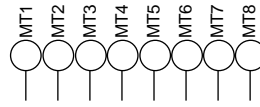

Index

A

Analog Section 39
AUX Input 8. *See also* Auxiliary Input
AUX Setup Menu 38
Auxiliary Input Offset and Gain 32
Auxiliary Input Pass/Fail Setup Menu 18
Auxiliary Scale Factor Setup 16

B

Baud Rate 19, 24
BITE. *See* Built-In Test System
Built-In Test Equipment 21
Buttons 5–6

C

Calibration 30
 Procedure 30–33
 Schedule 30
Calibration Commands 29
Carriage Return (CR). *See* Data Termination Characters
Closed-Box Calibration 30
Command Set 27
Commands
 Calibration 29
 Communication 27
 Setup 28
Communication Commands 27
Communication Parameters 24
Connection 11
 GPIB 22
 RS-232 23
Contrast 7
Controls and Buttons 5–6
CPU Section 40

D

Data Format 25
Data Points. *See also* Memory
 Recalling 20
 Storing 19
Data Sheet 3
Data Termination Characters 26
Direction Input Setup 15, 16
Direction Input Setup Menu 15

E

Encoder Setup 15

F

Features 1
Front Panel 5

Functions. *See also* Controls and Buttons
 Secondary 5

G

Gain
 Auxiliary Input 32
 Torque 31
General Purpose Interface Bus. *See* GPIB
GPIB
 Address 19
 Connection 22
 Interface 9, 22–23
 Primary Address 23
GPIB Address Setup Menu 19
GPIB/IEEE-488. *See* GPIB

I

IEEE-488. *See* GPIB
Input/Output (I/O) Parameter Setup 19
Input/Output (I/O) Section 41
Inputs 8
 Auxiliary 8
Internal Memory. *See* Memory

K

Keypad 43

L

LabVIEW Programming Examples 35
Line Feed (LF). *See* Data Termination Characters
Line Voltage 10

M

Main Menu 12
Max Power Setup 14, 16
Memory 19–20. *See also* Data Points
 Clearing 20
 Exiting 20
 Recalling 20
 Storing 19

Menus

AUX Setup 38
Auxiliary Input Pass/Fail Setup 18
Direction Input Setup 15
GPIB Address Setup 19
Main 12
Power Units 38
Power Units Setup 13
RS-232 Baud Rate Setup 19
Setup 36
Speed Pass/Fail Setup 18

Torque Pass/Fail Setup 17
Torque Units 37
Torque Units Setup 13

O

Offset

Auxiliary Input 32
Torque 31

Outputs 8. *See also* Inputs

P

Parameters 13–19
Pass/Fail Parameter Setup 17
PC Connection 24
Power Overload 14
Power Supply Section 42
Power Units Menu 38
Power Units Setup 13
Power Units Setup Menu 13
Programming 26

R

Rear Panel 8
Recalling Data Points 20
RS-232
 Connection 23
RS-232 Baud Rate Setup Menu 19
RS-232 Interface 23
RS-232C 8

S

Schematics

Analog Section 39
CPU Section 40
Input/Output (I/O) Section 41
Keypad 43
Power Supply Section 42

Secondary Functions 5

Self-Test 10

Setup

Auxiliary Scale Factor 16
Direction Input 15, 16
Encoder 15
GPIB Address 19
Input/Output (I/O) Parameters 19
Max Power 14, 16
Pass/Fail Parameters 17
Power Units 13
RS-232 Baud Rate 19
System Parameter 14
Torque Scale Factor 16
Torque Transducer - Custom 15–16
Torque Transducer - Standard 14–15
Torque Units 13

Setup Commands 28
Setup Menu 36
Simple Read 35
Speed Pass/Fail Setup Menu 18
Storing Data Points 19
System Parameter Setup 14
System Test 21

T

Tare Function 20
Timeout 26
Torque Meter Connector 8
Torque Offset and Gain 31
Torque Pass/Fail Setup Menu 17
Torque Scale Factor Setup 16
Torque Transducer Selection 14, 15
Torque Transducer Setup
 Custom 15–16
 Standard 14–15
Torque Units Menu 37
Torque Units Setup 13
Torque Units Setup Menu 13
Troubleshooting 34

U

Unpacking 1

V

Vacuum Fluorescent Display 7
VFD. *See* Vacuum Fluorescent Display

Magtrol Limited Warranty

Magtrol, Inc. warrants its products to be free from defects in material and workmanship under normal use and service for a period of 24 months from the date of shipment. Software is warranted to operate in accordance with its programmed instructions on appropriate Magtrol instruments. This warranty extends only to the original purchaser and shall not apply to fuses, computer media, or any other product which, in Magtrol's sole opinion, has been subject to misuse, alteration, abuse or abnormal conditions of operation or shipping.

Magtrol's obligation under this warranty is limited to repair or replacement of a product which is returned to the factory within the warranty period and is determined, upon examination by Magtrol, to be defective. If Magtrol determines that the defect or malfunction has been caused by misuse, alteration, abuse or abnormal conditions of operation or shipping, Magtrol will repair the product and bill the purchaser for the reasonable cost of repair. If the product is not covered by this warranty, Magtrol will, if requested by purchaser, submit an estimate of the repair costs before work is started.

To obtain repair service under this warranty, purchaser must forward the product (transportation prepaid) and a description of the malfunction to the factory. The instrument shall be repaired at the factory and returned to purchaser, transportation prepaid. **MAGTROL ASSUMES NO RISK FOR IN-TRANSIT DAMAGE.**

THE FOREGOING WARRANTY IS PURCHASER'S SOLE AND EXCLUSIVE REMEDY AND IS IN LIEU OF ALL OTHER WARRANTIES, EXPRESSED OR IMPLIED, INCLUDING BUT NOT LIMITED TO ANY IMPLIED WARRANTY OF MERCHANTABILITY, OR FITNESS FOR ANY PARTICULAR PURPOSE OR USE. MAGTROL SHALL NOT BE LIABLE FOR ANY SPECIAL, INDIRECT, INCIDENTAL, OR CONSEQUENTIAL DAMAGES OR LOSS WHETHER IN CONTRACT, TORT, OR OTHERWISE.

CLAIMS

Immediately upon arrival, purchaser shall check the packing container against the enclosed packing list and shall, within thirty (30) days of arrival, give Magtrol notice of shortages or any nonconformity with the terms of the order. If purchaser fails to give notice, the delivery shall be deemed to conform with the terms of the order.

The purchaser assumes all risk of loss or damage to products upon delivery by Magtrol to the carrier. If a product is damaged in transit, **PURCHASER MUST FILE ALL CLAIMS FOR DAMAGE WITH THE CARRIER** to obtain compensation. Upon request by purchaser, Magtrol will submit an estimate of the cost to repair shipment damage.



Testing, Measurement and Control of Torque-Speed-Power • Load-Force-Weight • Tension • Displacement

www.magtrol.com

MAGTROL INC

70 Gardenville Parkway
Buffalo, New York 14224 USA
Phone: +1 716 668 5555
Fax: +1 716 668 8705
E-mail: magtrol@magtrol.com

MAGTROL SA

Route de Moncor 4B
1701 Fribourg, Switzerland
Phone: +41 (0)26 407 3000
Fax: +41 (0)26 407 3001
E-mail: magtrol@magtrol.ch

Subsidiaries in:

- Germany
- France
- Great Britain

Worldwide Network
of Sales Agents

Magtrol SA ISO 9001:2000 certified

