Model 5250-2 Power Supply

1.0 INTRODUCTION

Model 5250-2 is an open frame, current regulated power supply for use with Magtrol hysteresis brakes and clutches.

1.1 Specifications

Current ranges	0–200 mA, 0–500 mA, 0–1000 mA
Current regulation	± 1% of full scale range
Compliance voltage	45 VDC
Control input	0–5 VDC
Current monitor output	0–200 mVDC
Brake fuse	1¼ Amp, UL/CSA, 5 × 20 mm (1 Amp, IEC, 5 × 20 mm)
Line fuses	120 VAC-1 Amp, UL/CSA, 5 × 20 mm (240 VAC-400 mA, IEC, 5 × 20 mm)
Power requirements	60 VA, 48–63 Hz

2.0 OPERATION

2.1 Ranges

Three current ranges are selectable by changing the position of two shunts on the header.

- For 0–200 mA, install shunts on J1 and J4.
- For 0–500 mA, use J2 and J5.
- For 0–1000 mA, use J3 and J6.

2.2 Input Power

The 5250 can be set for 120 VAC or 240 VAC operation. Solder pad jumpers are located on the underside of the PC board near the power transformer. For 120 VAC, bridge solder over pads J7 and J9 only. For 240 VAC, bridge the pad marked J8 only. You will also need to use the appropriate input fuse type. Connect input power to terminals 1 and 2 of J10, labeled L1 and L2.

2.3 Control

The 5250 provides smooth application of current from zero to maximum by either a ten-turn, 5 kOhm potentiometer, or by an external 0–5 VDC control signal.

For potentiometer control:

1. Wire the CCW side of the pot to terminal 5 of J10.
2. Wire the wiper to terminal 6.
3. Finally, wire the CW side of the pot to terminal 7.

If you wish to use an external signal to control the current level:

1. Connect the low side of the source (GND) to terminal 5 of J10.
2. Connect the high side of the source (positive going voltage) to terminal 6.

An input voltage of 0 VDC corresponds to 0 mA; 5VDC input to maximum current for the range selected.

2.4 Output

1. Connect one lead from the hysteresis brake to terminal 8 of J10.
2. Connect the other lead to terminal 9.



Note: Both terminals are above ground potential. Do not ground either terminal. Doing so will cause brake fuse F1 to open.

2.5 Current Metering

If you wish to monitor the current level with an external voltmeter:

1. Connect the negative lead to terminal 3 of J10.
2. Connect the positive lead to terminal 4.
3. The voltmeter should be set to a 200 mV range. The actual current to the brake will be the millivolt reading * 10.

3.0 CALIBRATION

When using a potentiometer to control output current, the voltage applied to the CW end of the pot should be 5VDC. This voltage is obtained from the 5250.

To calibrate:

1. Connect the negative lead of a voltmeter to terminal 5 of J10.
2. Connect the positive lead to terminal 7.
3. Turn on the 5250 and adjust potentiometer R4 for a 5.000V reading on the meter.

If an external current monitoring is used, each range of the 5250 may be calibrated individually.

1. Connect a load resistor of sufficient rating to allow 1000 mA of current to flow (typically 20 Ohms, 20 watts).
2. Attach a Standard Ammeter in series with the load resistor.
3. Set the jumpers to the 1000 mA range.
4. Power up the 5250 and adjust the control potentiometer (or control signal) to produce about 1000 mA output current, as read on the Standard Ammeter.
5. Adjust potentiometer R20 until both meters read the same.
6. Reduce the current to zero, and change the current range jumpers to the medium range.
7. Adjust the control for approximately 500 mA, as read on the Standard Ammeter.
8. Adjust R21 for an equal reading.
9. Repeat this procedure for the low range, using R22 for calibration.

A.0 APPENDIX A: PARTS LIST

Item	Qty.	Reference	Part	Magtrol P/N	Manufacturer's P/N
1	1		PC Board	78B189	78B189
2	1		SHCS 6-32 x ¼	505708	
3	1		Nut 6-32	505773	
4	1		Internal lockwasher	507710	
5	1	C1	Capacitor, 1000 uF, 50 V	70E009	
6	1	C8	Capacitor, 0.001 uF, Ceramic	70N023	
7	1	C7	Capacitor, 0.1 uF, 50 V	70N126	
8	1	C9	Capacitor, 47 pF, 50 V, 10%	70N135	
9	1	C6	Capacitor, 0.15 uF, 160 V	70N143	
10	4	C2-5	Capacitor, 1 uF, Tantalum	70T008	
11	1	BR1	Bridge Rectifier	71B005	HPE05
12	2	CR1,CR7	Diode	71S002	1N4004
13	2	CR8,CR9	Diode	71S005	1N4148
14	1	CR3	Zener Diode, 6.2 V	71Z001	1N821A
15	1	CR6	Zener Diode, 100 V	71Z011	1N6295A
16	1	CR4	Zener Diode, 6.2 V	71Z014	1N4735A
17	1	CR5	Zener Diode, 16 V	71Z015	1N4745
18	1	VR1	Voltage Regulator, +15 V	76L005	L7815CV
19	1	U1	Opamp, Dual	76L041	LM358A
20	3	R4,R20,R21	Trimpot, 1 kOhm	77M007	RT24C2W102
21	1	R22	Trimpot, 500 Ohm	77M026	RT24C2W501
22	2	R7,R8	Resistor, 10 k Ohm, ¼ Watt	80A103	
23	1	R23	Resistor, 10 MOhm, ¼ Watt	80A106	
24	2	R3,R11	Resistor, 1.5 kOhm, ¼ Watt	80A152	
25	1	R9	Resistor, 200 Ohm, ¼ Watt	80A201	
26	1	R24	Resistor, 5.1 kOhm, 1 Watt	80C512	
27	1	R1	Resistor, 560 Ohm, 1 Watt	80C561	41J560
28	1	R13	Resistor, 5 Ohm, 1 Watt, 1%	80P031	RS-1A
29	1	R14	Resistor, 2 Ohm, 3 Watt, 1%	80P032	RS-2B
30	2	R15,R25	Resistor, 1 Ohm, 3 Watt, 1%	RS-2B	
31	1	R19	Resistor, 2k Ohm, 1%	812001	
32	1	R12	Resistor, 2.49 kOhm, 1%	812491	
33	1	R5	Resistor, 499 Ohm, 1%	814990	
34	1	R18	Resistor, 8.45 kOhm, 1%	818451	
35	1	R10	Resistor, 9.09 kOhm, 1%	819091	
36	1	R16	Resistor, 90.9 kOhm, 1%	819092	
37	1	R17	Resistor, 9.53 kOhm, 1%	819531	
38	1	U1	DIP Socket, 8 Pin	85F068	
39	6	J10	Terminal Block	85F157	TSB-2
40	2		Shunt	85F187	
41	6	F1-3	Fuse Clip	85F192	
42	1	J1-6	Post Header	85M193	
43	1	T1	Custom Transformer	87V050	14A-56-1564

B.0 APPENDIX B: DRAWINGS

B.1 Schematic

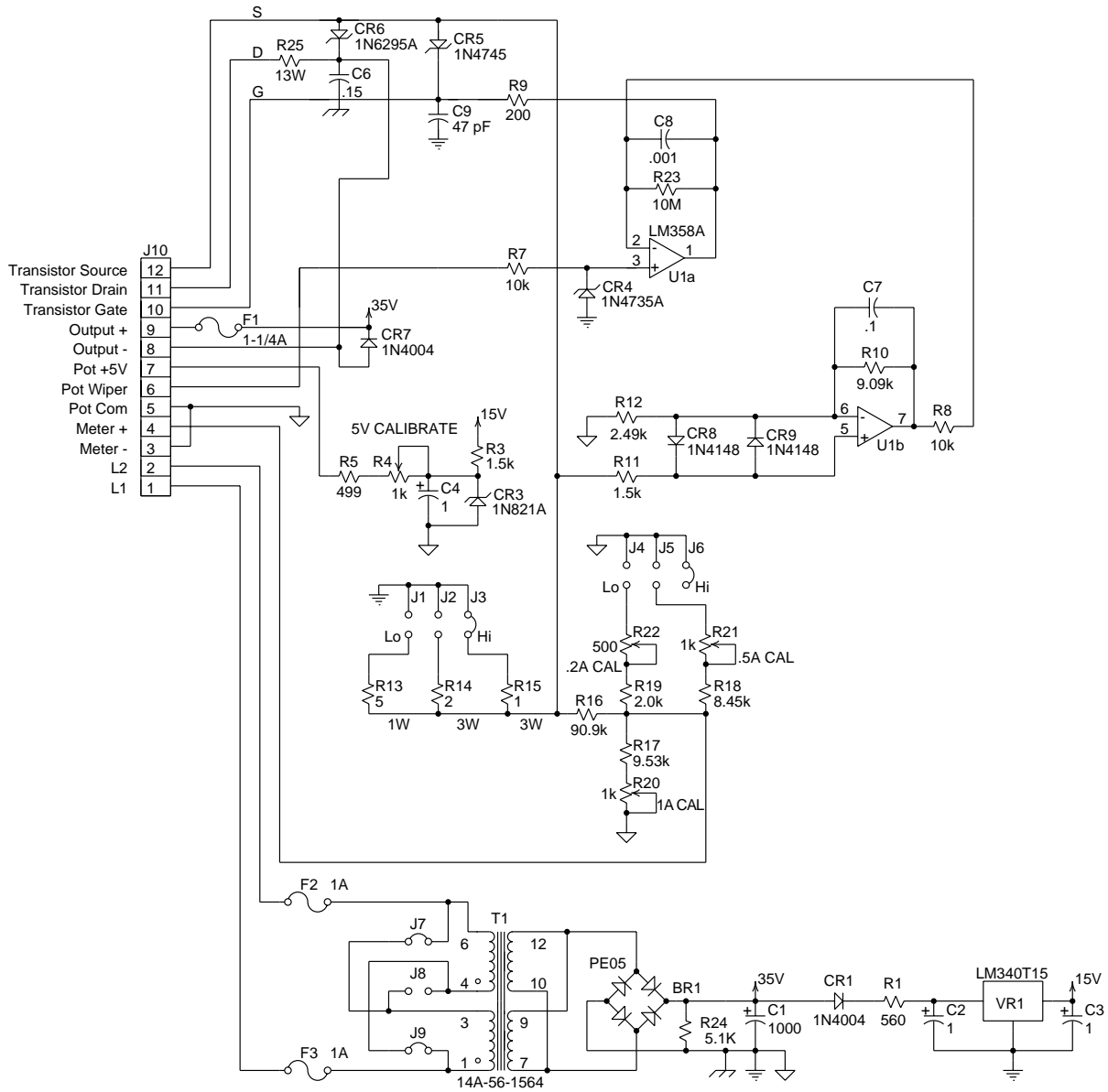

For 120V operation jumper J7 & J9 only

For 240V operation jumper J8 only

F1: 1-1/4 UL/CSA
1A IEC

F2, F3: 1A UL/CSA (120V)
400mA IEC (240V)

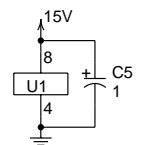

B.2 78B189 Silkscreen

