Model 5210-2 Power Supply

1.0 INTRODUCTION

The Model 5210-2 is a current-regulated power supply and display that is designed for use with Magtrol's Dial Weight Dynamometers. With regulated current, torque drift caused by temperature changes within the brake coil is eliminated.

The 5210 is a solid-state control that provides smooth application of current from zero to maximum. Braking power can be controlled manually from either the 10-turn potentiometer and adjustment knob on the front panel, or externally from the 0–5 VDC input when remote operation is desired. An LCD readout conveniently displays the applied braking current.



Note: Magtrol offers three different models of the 5210 Power Supply, each with a different maximum voltage output. The 5210-1 is 90 volts, 5210-2 is 24 volts, and the 5210-3 is 12 volts. All Magtrol Dial Weight Dynamometers are designed with a 24 volt coil. Therefore, the 5210-2 is the only power supply that should be used with a dial weight dynamometer. The 5210-1 and 5210-3 are for use with Magtrol brakes and clutches only.

1.1 SPECIFICATIONS

Brake Voltage	0 to 24 VDC
CURRENT RANGES:	
Low Scale	0 to 200 mA
Medium Scale	0 to 500 mA
High Scale	0 to 1000 mA
Current Regulation	± 1% Full Scale
Braking Control	10-turn potentiometer (internal) or 0–5 VDC input (external)
Brake Fuse (5 × 20 mm)	UL/CSA 1.25 A 250V SB IEC 1.00 A 250V T
Line Fuse (5 × 20 mm)	120 V: UL/CSA 1.0 A 250V SB 240 V: IEC 0.4 A 250V T
Power Requirements	100 VA
Voltage Requirements	120/240 V AC 50/60 Hz

1.2 FRONT AND REAR PANEL

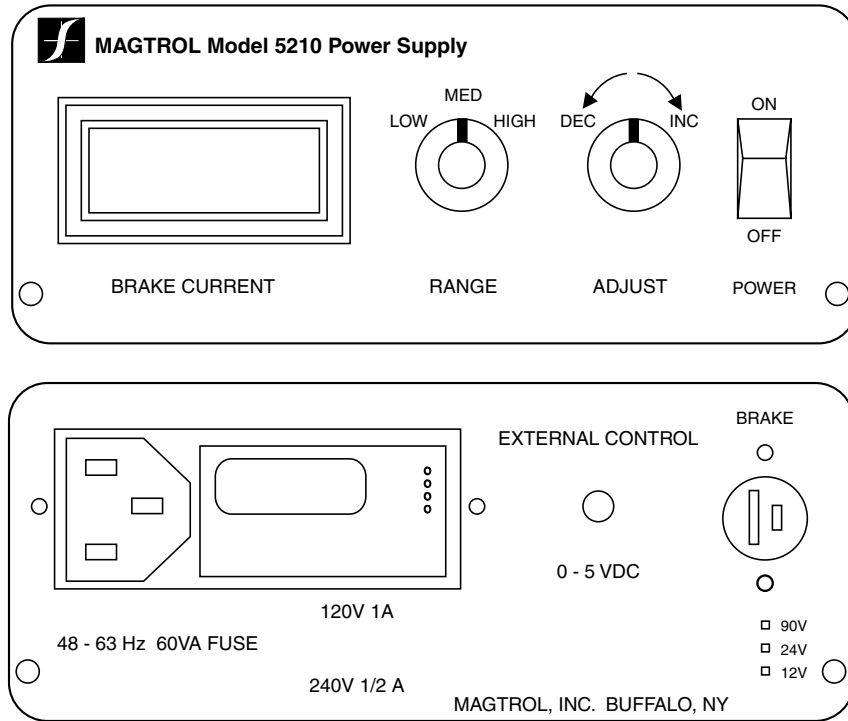

1.3 CIRCUIT DESCRIPTION

Functionally, the circuit is a closed loop, current feedback amplifier regulating the output current at the value set by the front panel controls.

DC current from the internal 35 volt power supply passes through the dynamometer coil connected at the BRAKE connector J6, through the insulated gate field effect transistor Q1 (HEXFET), and through a current sense resistor R13, R14 or R15 (selected by the RANGE control). The voltage drop across the current sense resistor is amplified by Operational Amplifier U1b and applied to the non-inverting differential input of Operational Amplifier U1a. Amplifier U1a amplifies the difference between the conditioned current signal from the sense resistor and the voltage from the front panel current ADJUST potentiometer, R6. This amplified error voltage is applied to the gate of transistor Q1 to control its channel resistance and thereby regulates the output current at the value set by the ADJUST control.

2.0 CONFIGURATION

2.1 INPUT POWER

The 5210-2 is shipped set for 120 V_{rms} power. This can be verified by observing the location of the round white tab in the fuse holder of the power line filter module that is located on the rear panel - it should show through the 120 V hole.

2.1.1 Setting Line Power to 240 V

1. Remove the line cord.
2. Remove the fuse holder to access the inner module.
3. Remove the small circuit board with the white tab.
4. Rotate and reposition the white tab so that when the board and fuse holder are reinserted, the round point of the white tab now inserts into the small round hole on the fuse holder that is opposite the 240 V position.



Note: Of the four (4) voltage positions shown on the fuse holder, only the 120 V and the 240 V positions are active. Selecting either the 100 V or the 220 V position will not apply line power to the power supply. Therefore, use only the 120 V or 240 V positions.

2.2 EXTERNAL CONTROL INPUT

An EXTERNAL CONTROL input is provided at the rear of the 5210-2 to adjust the dynamometer current from an external 0 to + 5.0 VDC input. This input is scaled for 5.0 VDC and equals the full scale output current of each current range (0.2, 0.5 and 1.0 amp).

When this connector is plugged in, the front panel ADJUST control is nonfunctional.

3.0 OPERATION

The 5210-2 is universal for all Magtrol Dial Weight Dynamometers. However, because of the wide range of full scale current requirements; 0 to 0.164 amps (HD-106-1) to 0 to 0.700 amps (HD-705-1), a three position current range control provides improved torque resolution control. The three settings, HIGH, MED and LOW determine the full scale current level of the power supply. Full scale for the HIGH, MED and LOW ranges are 1.0, 0.5 and 0.2 amps, respectively. The digital panel meter indicates the current output level to within $\pm 1\%$.

Starting on the LOW current range, with the ADJUST knob set fully counter clockwise (zero current), increase (INC) current until the desired torque is obtained. Select the next higher RANGE as necessary to obtain this torque.

APPENDIX A: SCHEMATIC

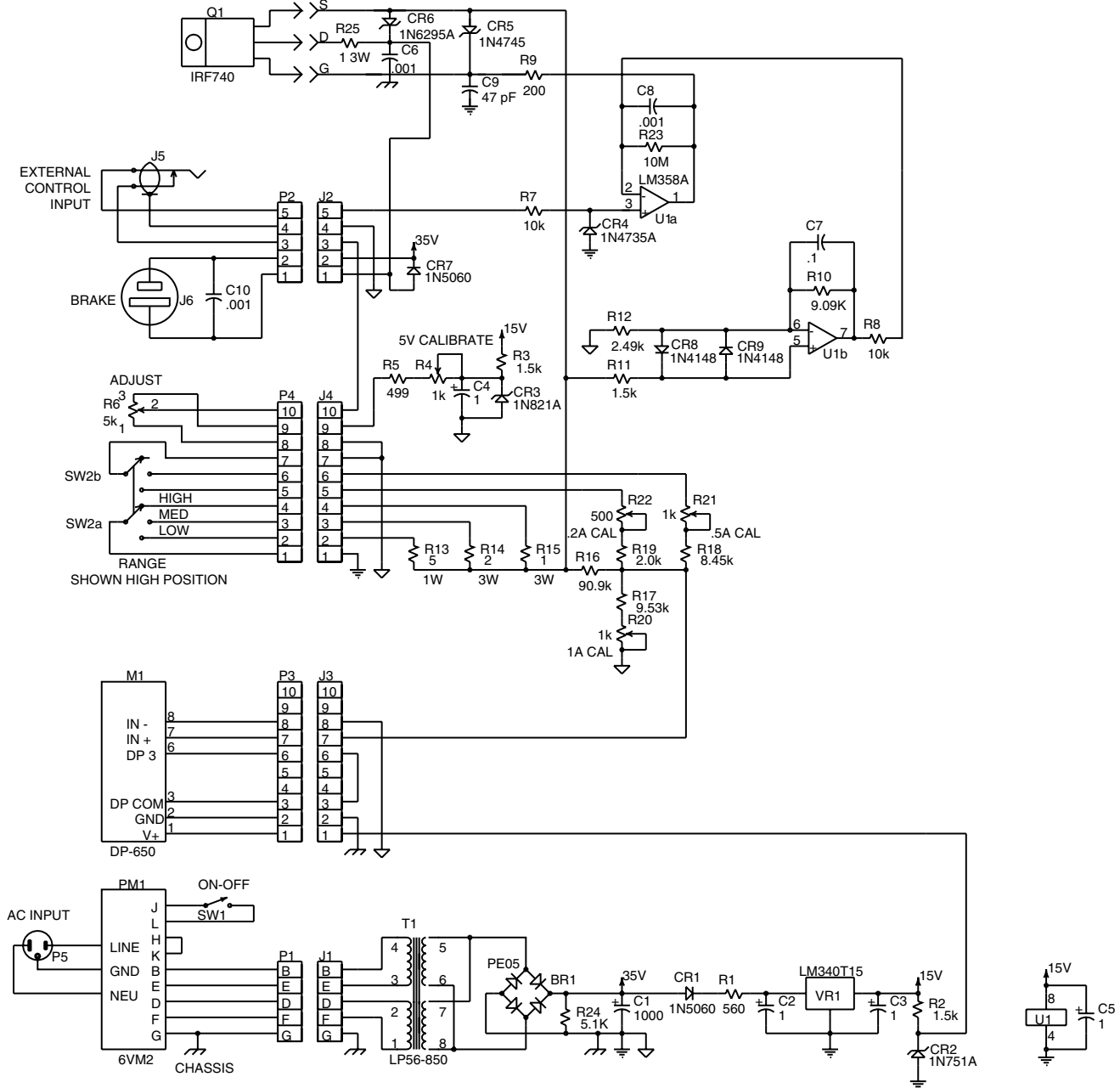

1st Edition – July 2006



Testing, Measurement and Control of Torque-Speed-Power • Load-Force-Weight • Tension • Displacement

www.magtrol.com

MAGTROL INC
 70 Gardenville Parkway
 Buffalo, New York 14224 USA
 Phone: +1 716 668 5555
 Fax: +1 716 668 8705
 E-mail: magtrol@magtrol.com

MAGTROL SA
 Centre technologique Montena
 1728 Rossens / Fribourg, Switzerland
 Phone: +41 (0)26 407 3000
 Fax: +41 (0)26 407 3001
 E-mail: magtrol@magtrol.ch

Subsidiaries in:
 • Germany
 • France
 • Great Britain
 • China
 Worldwide Network
 of Sales Agents

