

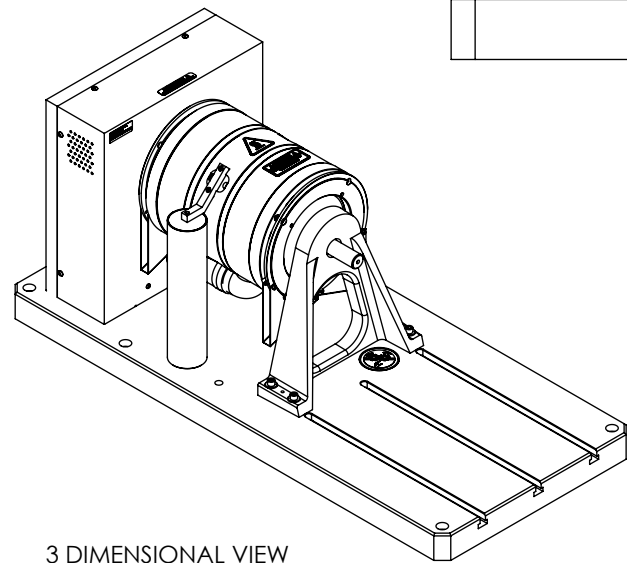

DETAIL A
SCALE 1 : 1

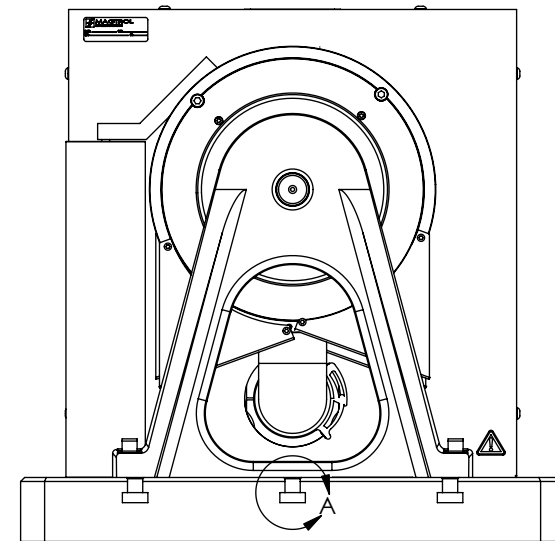
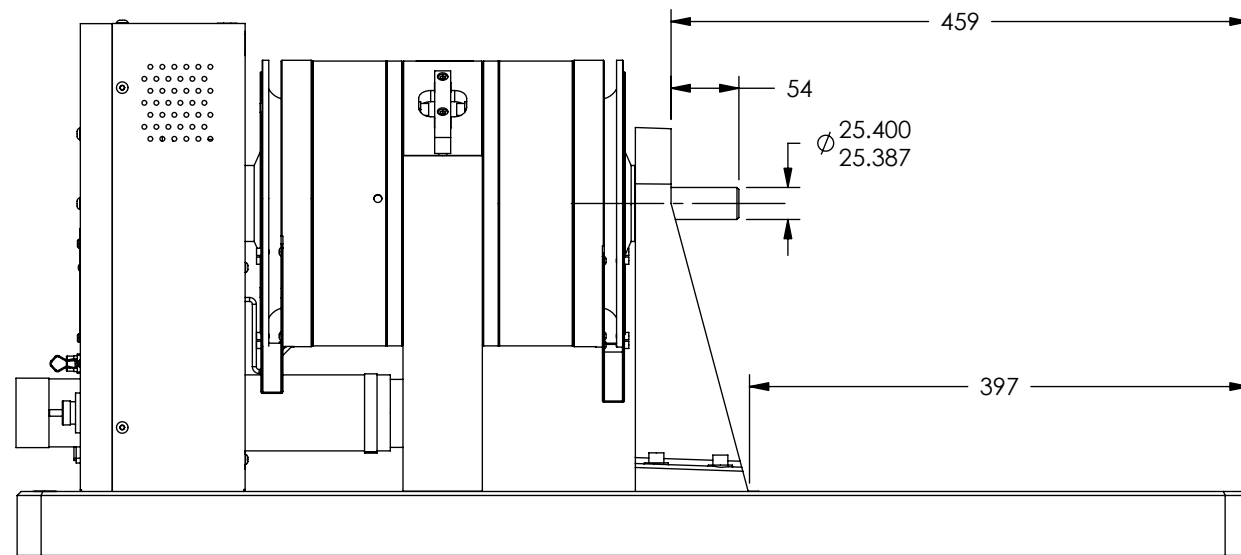

3 DIMENSIONAL VIEW
SCALE 1 : 12

LETTER	DATE	BY	ECN	DESCRIPTION
REVISIONS				

MATERIAL:	DESIGN	DTW	04-15-05	 MAGTROL INC. 70 GARDENVILLE PKWY, W. BUFFALO, NEW YORK 14224-1322		
	DRAWN	DTW	05-09-06			
FINISH:	CHECKED			TITLE		
				HD-815-DNC-0200		
				USED ON:		
				SIMILAR TO:		
				DWG. NO.	REV	
				185596	-	
				SIZE	SCALE	SHEET #
				B	1:6	1 OF 1

THIRD ANGLE PROJECTION

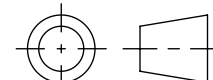

THIS DRAWING AND SPECIFICATION CONTAINS PROPRIETARY INFORMATION TO MAGTROL INC. ANY DISCLOSURE OR REPRODUCTION OF THIS DOCUMENT WITHOUT WRITTEN AUTHORIZATION FROM MAGTROL INC. IS EXPRESSLY PROHIBITED

UNLESS OTHERWISE SPECIFIED:
 DIMENSIONS ARE IN MILLIMETERS,
 DIAMETERS CONCENTRIC: .08 TIR,
 FACES PERPENDICULAR: .08
 INTERPRETATION PER ASME
 Y14.5M-1994
 REMOVE ALL BURRS AND BREAK
 SHARP EDGES .13/.25 X 45°
 INSIDE CORNERS TO BE .5 R MAX.
 TOLERANCES:
 X ± .4 .XX ± .13
 X ± .25 ANG. ± 1°
 SURFACE FINISH 3.2 μm MAX. U.O.S.