

AC89@	HC FEI 9 A 95G F9 I B#7C89 fL LLL	GC7? 7C89	A 5L-AIA HC FEI 9 F5B; 9	8F5; HC FEI 9 89 9B9F; #98 5H%\$\$\$ FDA	BCA B5@BDI HB9FH5		A 5L-AIA DCK 9F		A 5L-AIA GD998 fFDA L	7CC@B;
<8!, \$\$!LLL	)B	\$\$*++-	%( "\$\$B'a	\$"%\$B'a	("(' 1'%'	*"%'L'%'	&Z \$\$	%Z \$\$	%&Z\$\$\$	7C A DF9GG98 5 F1 fH") 7: A 4 '+DGŁ
	)B5	\$\$*+, \$								
	*B	\$\$) -) -	%(&) "\$'V'jb	\$", 'V'jb						
	*B5	\$\$) - *%								
	+B	\$\$) - *'	%( "\$\$_[ 'Wb	%"\$_[ 'Wb						
	+B5	\$\$) - *)								
	, B	\$\$) - *+	%( "\$\$B'a	\$"%\$B'a						
, B5	\$\$) - *-									

GC @8' A C 89@5J 5-56@

' 8-A 9BGCB5@J -9K  
G7 5@%&

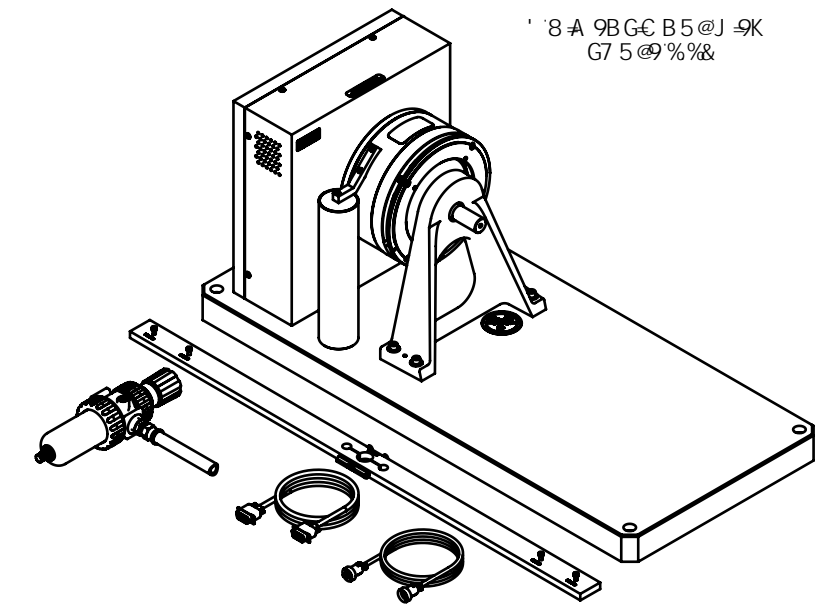

I F9E I F9G5 F7CC @B; DFCJ B98 6M7I GCA 9F" F9; I @HC F5B8: 4DF D57?5; 9 GDFCJ B98 5GG5B85F8 9E I DA 9BH

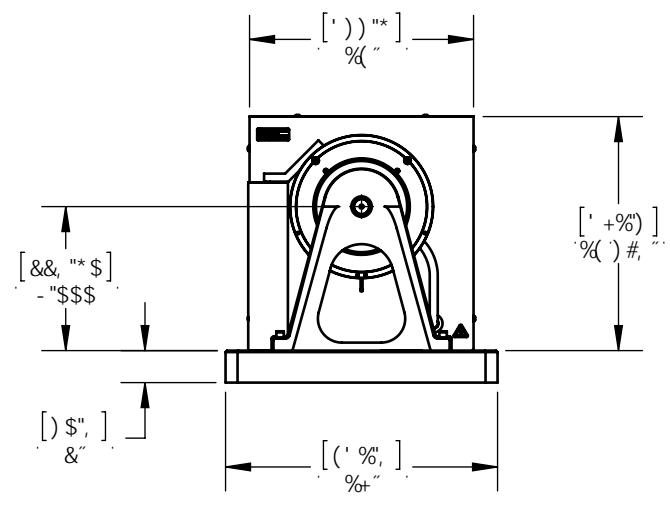
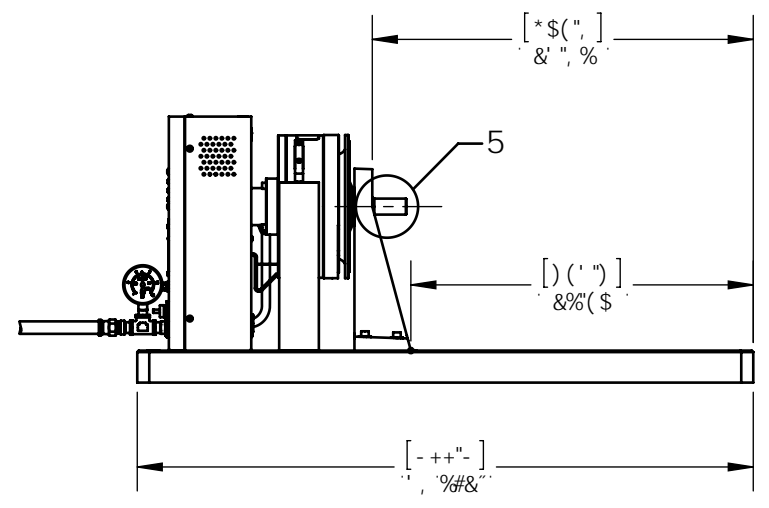
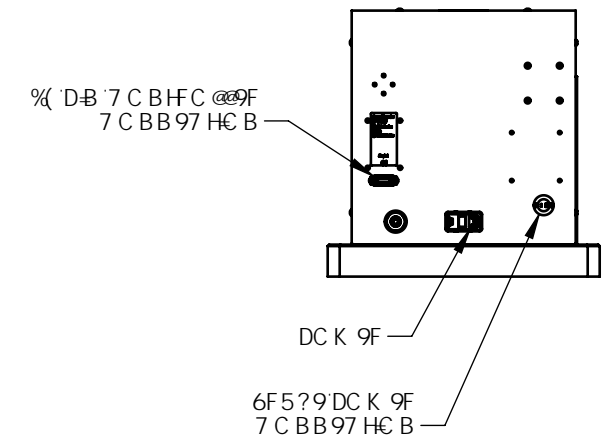
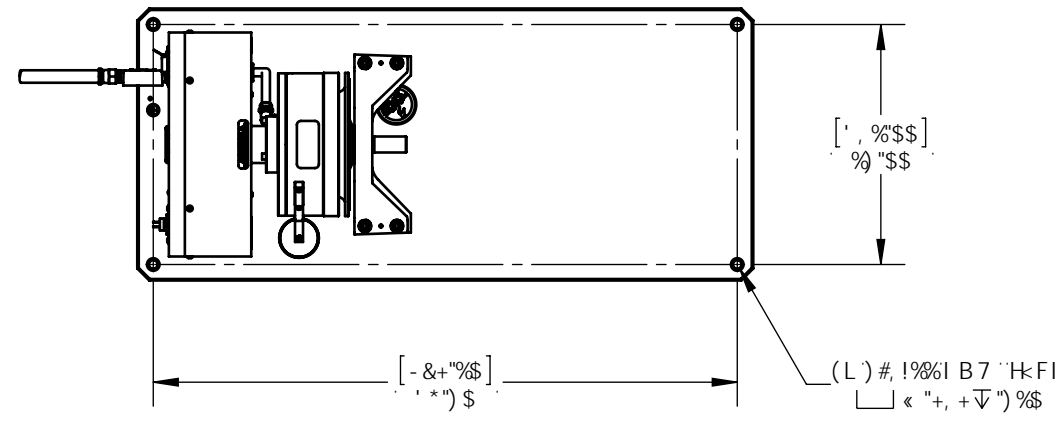
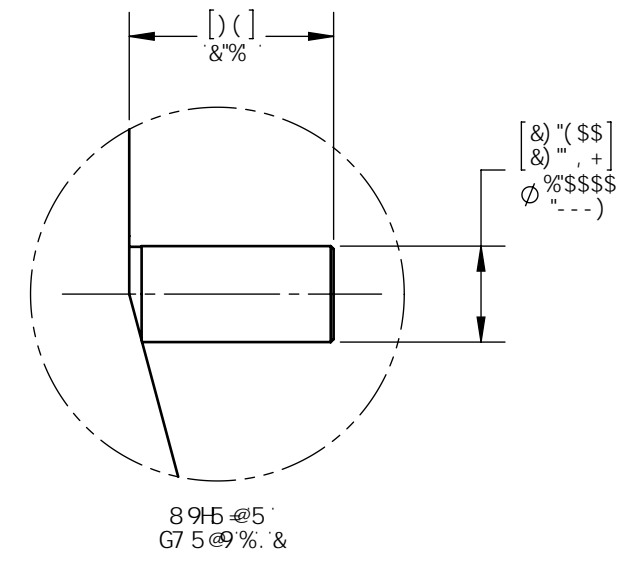

BG5@5HC B 8F5K B;

BC H9: '8-A 9BGCBG-B'005F9'a a "

A 5HF-5@	89G= B	!	!	<p><b>A 5; HFC@B7"</b> + \$; 5F89BJ @9D?K MZK " 6l : : 5@ZB9K 'MCF?%'&amp;&amp;(1%&amp;&amp;</p>
! :	8F5K B	>9.	\$, # \$#98%	
: B Gc.	7 <97 ?98	5 >7	\$- # \$%#98%	<p>&lt;8!, \$\$'8MB5A CA 9H9F</p>
Hk F8 5B; @ DFC >97 HC B	<p>I B@GGC H: 9FK @9GD97 = 98. 8-A 9BGCBG5F9-B B7 &lt;9G 8-5A 9HFG7CB7 9H F7. "\$\$ ' HF : 57 9GD9FD9B8 71 @5F. "\$\$ BH9F DF9H5HC B 'D9F '5GA 9 'M%(') A 1% - ( F9A C J 95 @6I FFG5B8 '6F95? '&lt;5FD98; 9G '\$\$) # '\$\$' L(') S BG897 CFB9FGHC '69F "\$&amp;A 5L HC @9F5B7 9G "LL - "\$% L#M - %#" (" "LLL - "\$\$\$) LS - %\$</p>			
Hk G8F5K B; 5B8 GD97 = 7 5HC B 7C B H5 BGDFC DF 9H5 FM B; CFA 5HC B HC A 5; HFC @B7 " 5B M8 67 @G F9 CF F9DFC 81 7HC B C; H: 68C71 A 9BH K #C I HK F H9B 51 H: C F #5HC B : FC A A 5; HFC @B7 " 69L DF 9GG @MDFC < 6H98	G4P	G7 5@9	G-99H.	<p>6 %&amp;&amp; &amp;C: ' &amp;</p>