

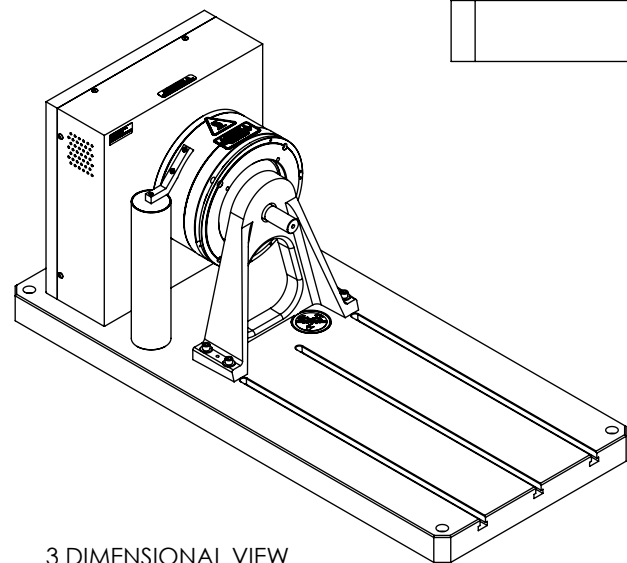

DETAIL A
SCALE 1:1

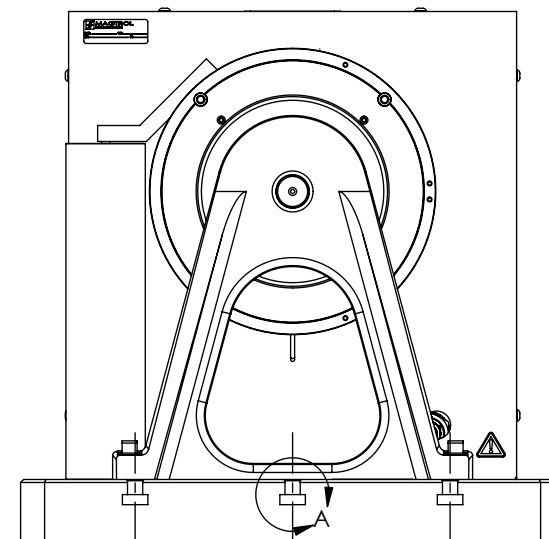
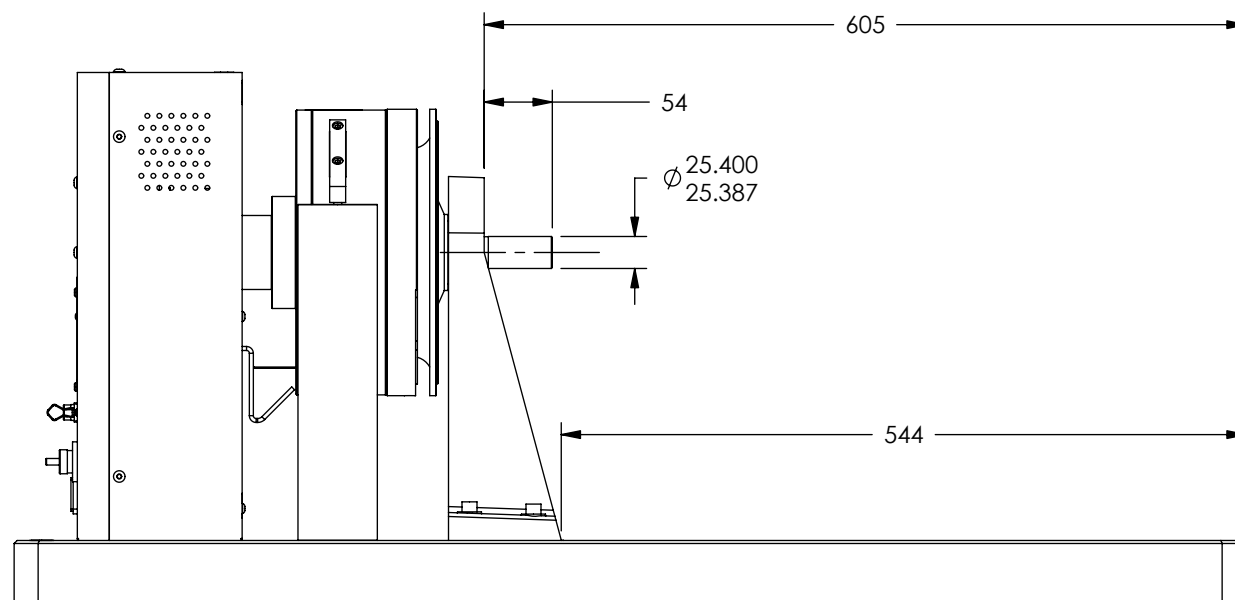

3 DIMENSIONAL VIEW
SCALE 1:12

LETTER	DATE	BY	ECN	DESCRIPTION
REVISIONS				

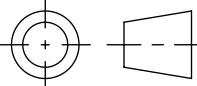
MATERIAL:	DESIGN	DTW	04-03-06	 MAGTROL INC. 70 GARDENVILLE PKWY, W. BUFFALO, NEW YORK 14224-1322
	DRAWN	DTW	04-04-06	
FINISH:	CHECKED			TITLE HD-800-DNC-0200 CONSOLIDATED NO KEY SEAT USED ON: SIMILAR TO: DWG. NO. 185593
THIRD ANGLE PROJECTION 	UNLESS OTHERWISE SPECIFIED: DIMENSIONS ARE IN MILLIMETERS, DIAMETERS CONCENTRIC: .08 TIR, FACES PERPENDICULAR: .08 INTERPRETATION PER ASME Y14.5M-1994 REMOVE ALL BURRS AND BREAK SHARP EDGES .13/.25 X 45° INSIDE CORNERS TO BE .5 R MAX. TOLERANCES: X ± .4 .XX ± .13 X ± .25 ANG. ± 1° SURFACE FINISH 3.2 μm MAX. U.O.S.			
THIS DRAWING AND SPECIFICATION CONTAINS PROPRIETARY INFORMATION TO MAGTROL INC. ANY DISCLOSURE OR REPRODUCTION OF THIS DOCUMENT WITHOUT WRITTEN AUTHORIZATION FROM MAGTROL INC. IS EXPRESSLY PROHIBITED				SIZE B SCALE 1:6 SHEET # 1 OF 1