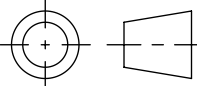

NOTE: DIMENSIONS IN [] ARE MILLIMETERS

| | | | | |
|--|---|-----|----------|--|
| MATERIAL: - | DESIGN | AJC | 07/29/08 |  MAGTROL INC. 70 GARDENVILLE PKWY, W. BUFFALO, NEW YORK 14224-1322 |
| | DRAWN | AJC | 07/29/08 | |
| FINISH: - | CHECKED | - | - | TITLE FIXED MOTOR FIXTURE, 700 SERIES, 006487 |
| THIRD ANGLE PROJECTION |  | | | UNLESS OTHERWISE SPECIFIED: DIMENSIONS ARE IN INCHES, DIAMETERS CONCENTRIC: .003 TIR, FACES PERPENDICULAR: .003 INTERPRETATION PER ASME Y14.5M-1994 REMOVE ALL BURRS AND BREAK SHARP EDGES .005/.010 X 45°, ALL INSIDE CORNERS TO BE .02 R MAX. TOLERANCES: .XX ± .01 FRAC. ± 1/64" .XXX ± .005 ANG. ± 1° SURFACE FINISH 125 RMS MAX. U.O.S. |
| THIS DRAWING AND SPECIFICATION CONTAINS PROPRIETARY INFORMATION TO MAGTROL INC. ANY DISCLOSURE OR REPRODUCTION OF THIS DOCUMENT WITHOUT WRITTEN AUTHORIZATION FROM MAGTROL INC. IS EXPRESSLY PROHIBITED | | | | USED ON: - SIMILAR TO: 006486 DWG. NO. FMF-700-TAB REV - SIZE B SCALE 1:8 SHEET # 2 OF 2 |