

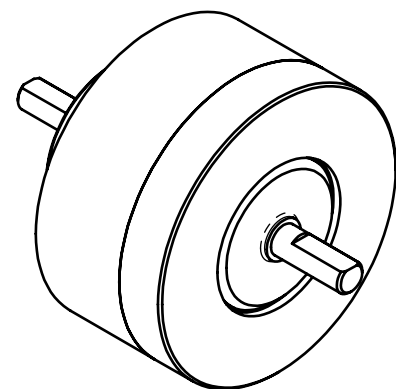

SOLID MODEL AVAILABLE

MODEL	STOCK CODE	MINIMUM TORQUE (oz in)	MAXIMUM SPEED (RPM)	KINETIC POWER RATINGS		EXTERNAL INERTIA (lb in s <sup>2</sup> )	ANGULAR ACCELERATION (rad/s <sup>2</sup> )
				5 MINUTE (watts)	CONTINUOUS (watts)		
HPMC-8	004618	8	10,140	60	15	$3.3 \times 10^{-5}$	15,200

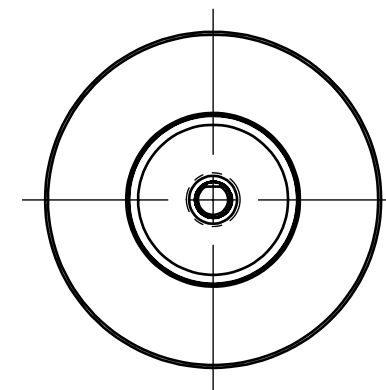
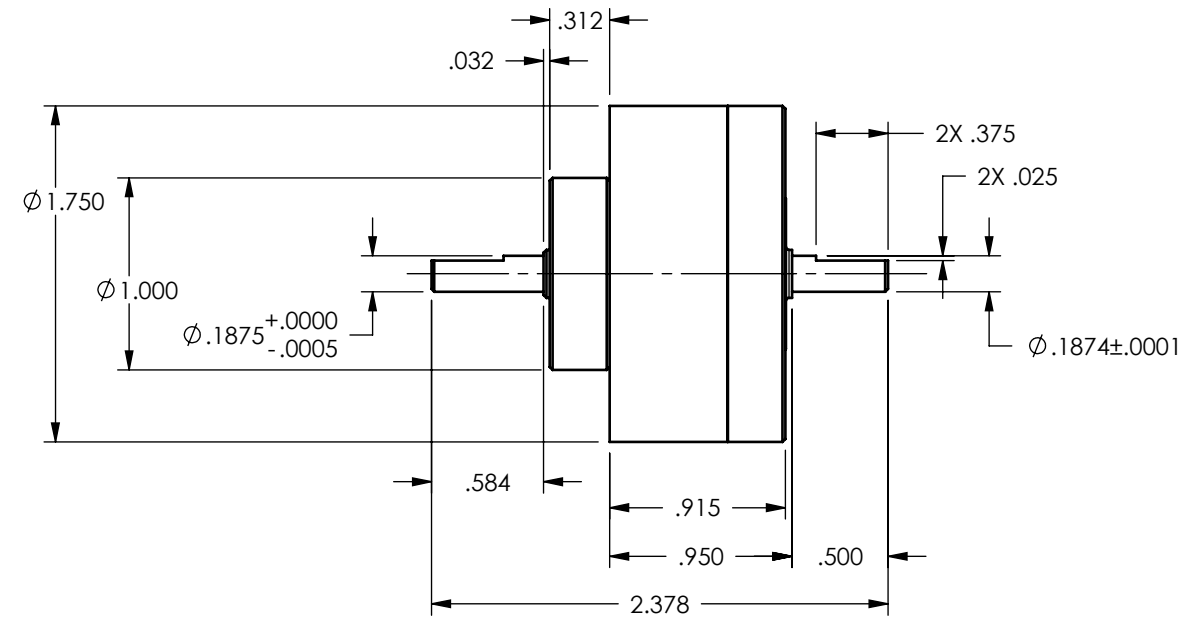
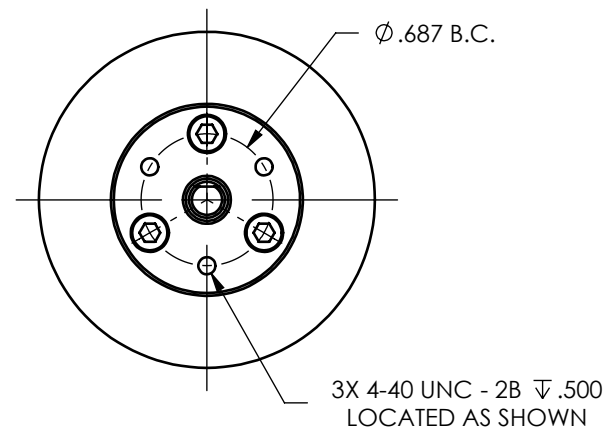

3 DIMENSIONAL VIEW  
SCALE 1 : 1

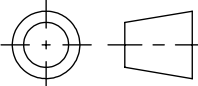
MATERIAL:	DESIGN	-	-	 <b>MAGTROL INC.</b> 70 GARDENVILLE PKWY, W. BUFFALO, NEW YORK 14224-1322
	DRAWN	AJC	02/10/10	
FINISH:	CHECKED	JEF	05/03/10	TITLE <b>PERMANENT MAGNET CLUTCH</b> USED ON: - SIMILAR TO: -
THIRD ANGLE PROJECTION				
THIS DRAWING AND SPECIFICATION CONTAINS PROPRIETARY INFORMATION TO MAGTROL INC. ANY DISCLOSURE OR REPRODUCTION OF THIS DOCUMENT WITHOUT WRITTEN AUTHORIZATION FROM MAGTROL INC. IS EXPRESSLY PROHIBITED				UNLESS OTHERWISE SPECIFIED: DIMENSIONS ARE IN INCHES, DIAMETERS CONCENTRIC: .003 TIR, FACES PERPENDICULAR: .003 INTERPRETATION PER ASME Y14.5M-1994 REMOVE ALL BURRS AND BREAK SHARP EDGES .005/.010 X 45°. ALL INSIDE CORNERS TO BE .02 R MAX. TOLERANCES: .XX ± .01      FRAC. ± 1/64" .XXX ± .005    ANG. ± 1° SURFACE FINISH 125 RMS MAX. U.O.S.
DWG. NO.			HPMC-8	REV
SIZE	SCALE	SHEET #		
B	1:1	2 OF 2		