

SBB 14 Signal Breakout Box

FEATURES

- Two 14-Pin Connectors: provide easy access to speed and torque readings from a Magtrol motor testing instrument and corresponding controller
- Three BNC Connectors: for outputting speed and torque signals to an oscilloscope or other data acquisition (DAQ) device
- Sturdy Assembly: packaged in a shielded aluminum case with metal mounting flanges
- Encoder input for high resolution encoders.
- Jumper for supplying +24 VDC regulated voltage to transducer.

DESCRIPTION

Magtrol's SBB 14 Signal Breakout Box is designed to assist in the monitoring of speed and torque signals obtained from either a Magtrol DSP Controller or 3410 Torque Display. The easy-to-use SBB 14 is simply inserted in series between the controller and any Magtrol Dynamometer or Torque Transducer. Connections are made via 14-pin signal cables.

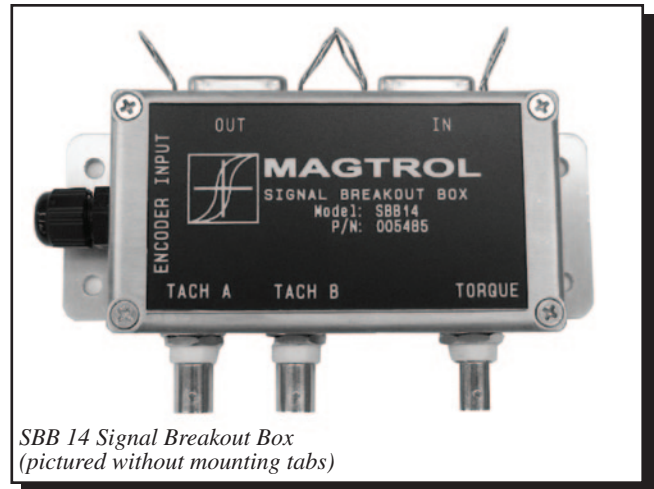

*SBB 14 Signal Breakout Box
(pictured without mounting tabs)*

Speed and torque signals are then outputted through BNC connectors to an oscilloscope or other DAQ instrumentation. The SBB 14 Signal Breakout Box is a convenient and reliable accessory that reduces the necessary wiring required for signal monitoring.

SYSTEM CONFIGURATION

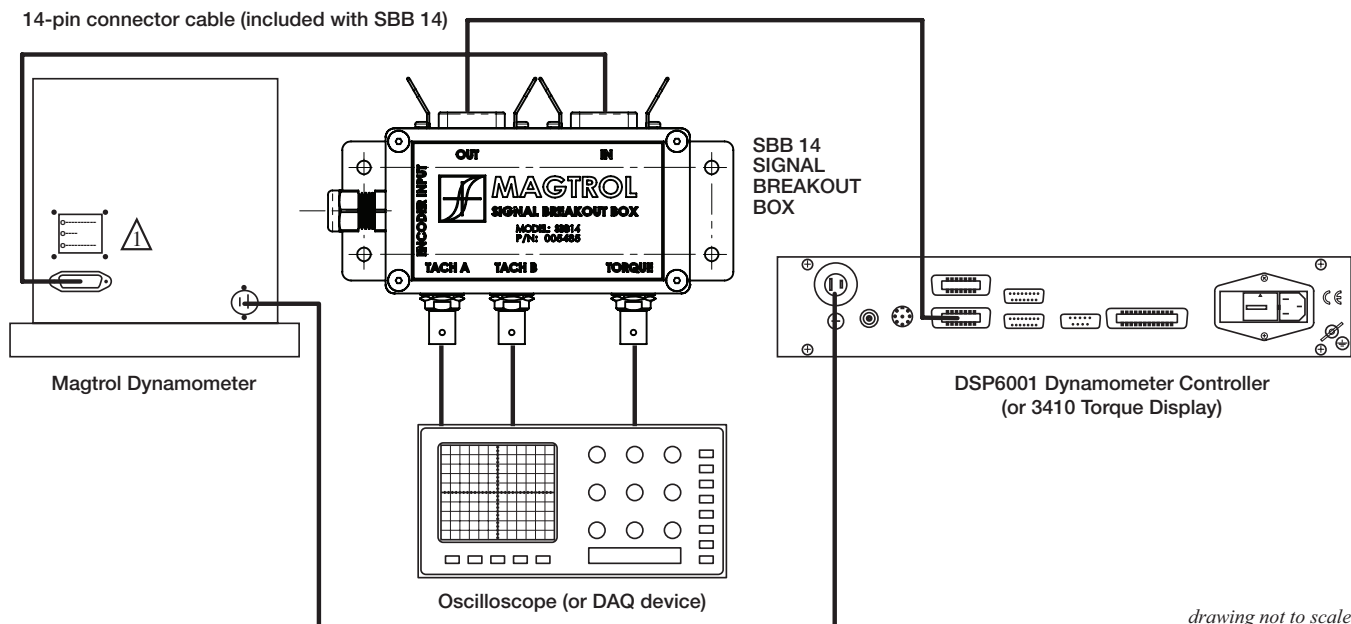

SYSTEM CONFIGURATION

14-pin connector cable (included with SBB 14)

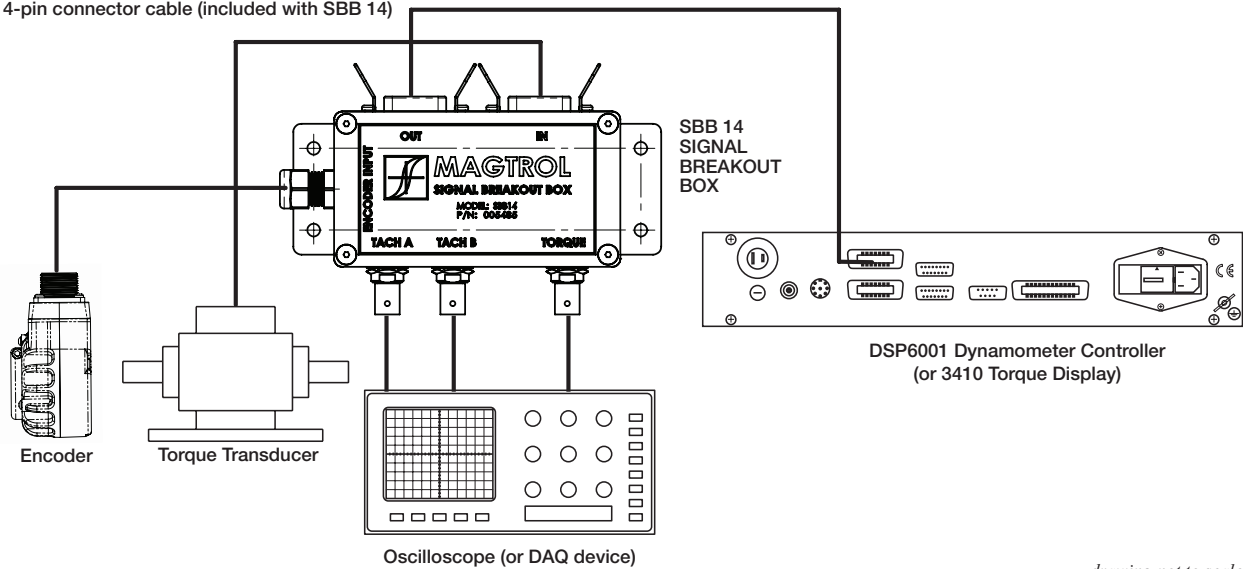

drawing not to scale

DIMENSIONS

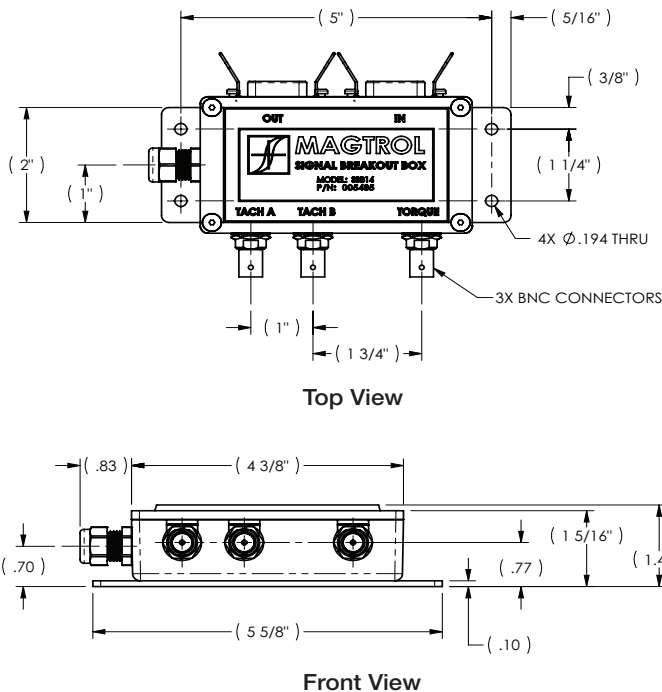

ORDERING INFORMATION

The SBB 14 Signal Breakout Box is supplied with a 14-pin, 2.5 ft dynamometer/transducer patch cable.

Due to the continual development of our products, we reserve the right to modify specifications without forewarning.



www.magtrol.com

MAGTROL INC
 70 Gardenville Parkway
 Buffalo, New York 14224 USA
 Phone: +1 716 668 5555
 Fax: +1 716 668 8705
 E-mail: magtrol@magtrol.com

MAGTROL SA
 Route de Montena 77
 1728 Rossens/Fribourg, Switzerland
 Phone: +41 (0)26 407 3000
 Fax: +41 (0)26 407 3001
 E-mail: magtrol@magtrol.ch

Subsidiaries in:
 Germany • France
 China • India
 Worldwide Network
 of Sales Agents

