

---

# EM-TEST 1.0

## Endurance Motor Testing Software

---

### SPECIFIC FEATURES

- **Global Project:** Manages Data and Setup of the current project.
- **Automatic GPIB and DAQmx Device/Address Detection:** Displayed within program to easily check communication parameters.
- **Lock / Unlock function:** Front Panel lock function prevents modification by an unauthorized operator.
- **Set-point table:** The set-point curve is defined in the data table. Sampling rate, voltage and relay state are also defined in this table.
- **Endurance Testing:** Tests speed, torque, amps, watts input, watts output and open loop parameters. Capable of adjusting sampling rate by step and using step or ramp from one load point to the next.
- **Relay Control:** Up to 6 customized relay controls.
- **Temperature Measurement:** Up to 8 thermocouple channels are included in the standard program.
- **Temperature Security:** Over-Temperature control and Hysteresis Temperature function.
- **Three-Phase Power Meter Data Acquisition:** Obtain data on each individual phase and/or the sum used in the chosen parameters (amps, volts, input watts and power factor).
- **Spanning file function:** Auto-Incrementation of filename depending on cycle, hours, days or file size.
- **Graph and display during test:** Displays previous files during test in tabular or graphic view.
- **Recovery Function:** Recovers test if the computer crashes (Windows® problem, power off).



*EM-TEST 1.0 Configuration Test*

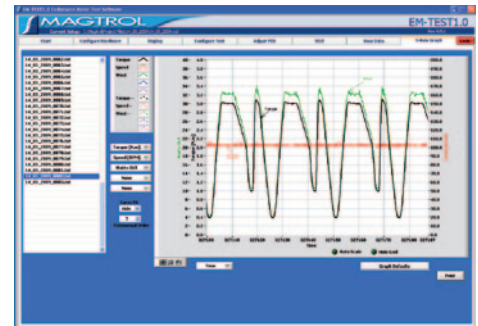

*EM-TEST 1.0 Graphical Data Output*

### DESCRIPTION

Magtrol's new EM-TEST 1.0 is an endurance motor testing Program for PC (Windows®XP/VISTA) based data acquisition. Combined with a Magtrol DSP6001 High Speed Programmable Controller, EM-TEST 1.0 works with any Magtrol dynamometer or in-line torque transducer to determine the performance characteristics of a motor under test. Up to 30 parameters are calculated and displayed utilizing EM-TEST 1.0's unique testing and graphing capabilities.

An integral component of any Magtrol Endurance Motor Test System, EM-TEST 1.0 performs curve testing in a manner best suited to the overall efficiency of the test rig. Written in LabVIEW™, EM-TEST 1.0 has the flexibility to test a variety of motors in a multitude of configurations. The data generated

from this user-friendly program can be stored, displayed and printed in tabular or graphical formats, and is easily imported into a spreadsheet.

Magtrol can also make custom modifications to the software to meet additional motor testing requirements.

### APPLICATIONS

EM-TEST 1.0 is designed for long-term motor test cycling. It is ideal for developmental applications. It has the ability to duplicate tests and run them automatically. This versatile program is extremely valuable to anyone involved in motor testing. EM-TEST 1.0 can be used as stand alone software or in combination with M-TEST 5.0 Motor Testing Software.

## STANDARD FEATURES

- **IEEE-488:** Computer interface with National Instruments™ PCI-GPIB.
- **Multiple Language Support:** Switch to/from English, French, German at any point during the program. Additional language dictionaries can be created/edited by the user.
- **Automatic Load Defaults Option:** Downloads testing instrument parameters based on model number.
- **PID Adjustment Routines:** Helps adjust the system for step functions.
- **Rapid Graph Plotting:** Change both the X- and Y-axis to display additional test curves, without having to exit the graph.
- **Displays 30 Tested and Calculated Parameters:** Torque, speed and auxiliary input are displayed from the DSP6001. Amps, volts and watts are displayed from a (optional) power analyzer. Calculated values including horsepower, efficiency, power factor, output watts, cycle and time can also be displayed.
- **Curve Fitting:** A curve fitting routine can be applied to most motor test curves. Raw data and curve fit data can also be displayed simultaneously.
- **Context Help:** Hover over any field or parameter with the mouse to display a context help box.

## TEMPERATURE SENSOR MEASUREMENT

Up to 4 thermocouples can be read and monitored during a motor test. Heat rise curves on the bearings, windings and housing of a motor can be performed.

EM-TEST 1.0, with its complete dynamometer control, allows for sensor measurement while performing load simulation for duty cycle and life testing.

**Hysteresis function :** If the temperature exceeds the high threshold, the test passes to Pause mode and a relay is disabled. When the temperature passes under the low threshold, the test passes to Run mode and a relay is enabled.

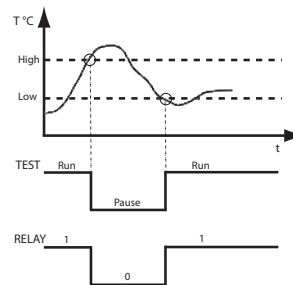

## RELAY CONTROL

Up to 6 relays can be controlled during test. The state of each relay can be set for each step.

## SYSTEM CONFIGURATION

A Magtrol Dynamometer provides motor loading with a Magtrol Programmable Controller acting as the interface between the PC running EM-TEST 1.0 and the dynamometer. If the motors' electrical parameters are to be measured or used to determine load points, a Magtrol Power Analyzer is also required. The computer and electronic instrumentation interface through the National Instruments™ PCI-GPIB card.

EM-TEST 1.0 is equipped to work in conjunction with any of the following Magtrol motor testing instruments:

- High Speed Programmable Controller (DSP6001)
- Hysteresis, Eddy-Current or Powder Dynamometer (HD, WB, PB)
- In-Line Torque Transducer (TM, TMB, TMHS)
- Power Analyzer (6530, 6510e, 6510)

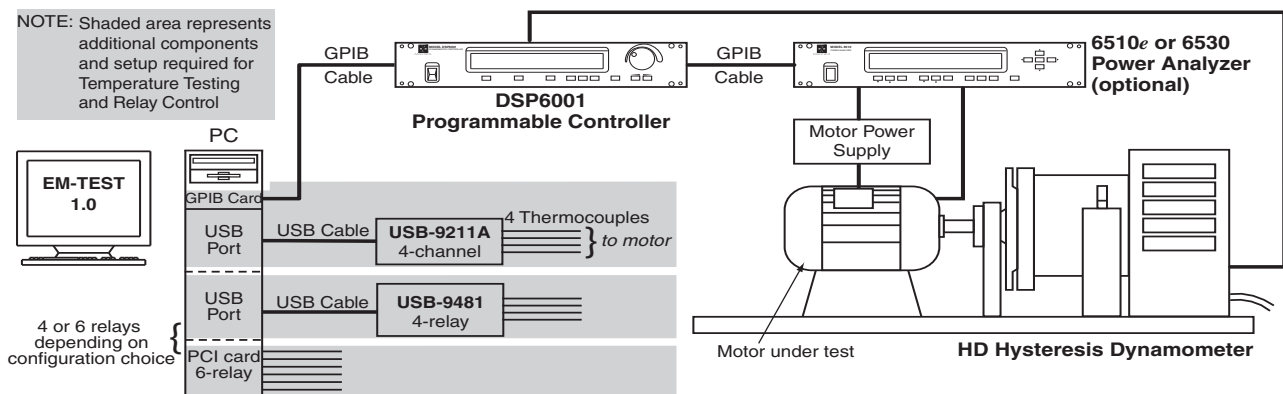

**SYSTEM REQUIREMENTS**

- Personal computer with Intel® Pentium® IV dual core 2Ghz or equivalent.
- Microsoft® Windows® XP / VISTA 32 bits.
- 2 GB of RAM or more.
- 1 GB of available hard drive space.
- VGA color monitor with minimum screen resolution of 1280 × 900.
- National Instruments™ PCI-GPIB card (available from Magtrol).
- National Instruments™ USB-9211A hardware: Required only if temperature sensor input function will be used.
- National Instruments™ USB-9481/PCI-652x hardware : required only if relay control function will be used.

**SYSTEM OPTIONS AND ACCESSORIES**

| CATEGORY                     | DESCRIPTION   | MODEL / PART #     |
|------------------------------|---|--------------------|
| TEMPERATURE TESTING HARDWARE | USB 4-Channel Isolated Input Module (USB-9211A) and USB Cable (1 m) | HW-TTEST-USBA      |
| RELAYS CARDS                 | PCI card 6 relays 150V AC/DC 2A max. 60 W                           | HW-RLTEST-PCI      |
|                              | USB card 4 relays 30V DC 2A max. 60 W                               | HW-RLTEST-USB      |
| CONTROLLERS                  | High Speed Programmable Controller                                  | DSP6001            |
| MOTOR TEST EQUIPMENT         | Hysteresis Dynamometers   | HD series          |
|                              | Eddy-Current Dynamometers   | WB series          |
|                              | Powder Brake Dynamometers   | PB series          |
|                              | In-Line Torque Transducers  | TM/TMHS/TMB series |
| POWER ANALYZERS              | High Speed Single-Phase Power Analyzer                              | 6510e              |
|                              | High Speed Three-Phase Power Analyzer                               | 6530               |
| CARDS                        | GPIB Interface Card (PCI)   | 73-M023            |
| CABLES                       | GPIB Cable, 1 meter   | 88M047             |
|                              | GPIB Cable, 2 meters  | 88M048             |
|                              | Torque Transducer Connector Cable                                   | ER 113/01          |

*Due to the continual development of our products, we reserve the right to modify specifications without forewarning.*

[www.magtrol.com](http://www.magtrol.com)
**MAGTROL INC**

70 Gardenville Parkway  
 Buffalo, New York 14224 USA  
 Phone: +1 716 668 5555  
 Fax: +1 716 668 8705  
 E-mail: [magtrol@magtrol.com](mailto:magtrol@magtrol.com)

**MAGTROL SA**

Centre technologique Montena  
 1728 Rossens/Fribourg, Switzerland  
 Phone: +41 (0)26 407 3000  
 Fax: +41 (0)26 407 3001  
 E-mail: [magtrol@magtrol.ch](mailto:magtrol@magtrol.ch)

**Subsidiaries in:**

Great Britain  
 Germany • France  
 China • India  
 Worldwide Network  
 of Sales Agents

