

Model 5600

Direction Indicator

FEATURES

- Displays motor status and direction of rotation via front panel LED indicators or user-provided lamp/lighting device
- Adjustable torque input levels to detect direction of rotation
- Directional indicator (CW/CCW) may be disabled if motor is not in motion

DESCRIPTION

The 5600 is used in conjunction with a Magtrol Hysteresis Dynamometer and Dynamometer Controller to provide a highly visible indication of motor status (running or stopped) and direction of rotation (clockwise or counterclockwise). The built-in LEDs on the front panel may be used as indicators or a 120 VAC lamp of up to 100 watts may be plugged into any or all of the front panel receptacles.

To indicate direction of rotation, a circuit monitors the torque signal (both negative and positive) and, at a pre-determined torque level set by a sensitivity potentiometer located on the rear panel, the circuit lights the appropriate LED (CW or



CCW). The encoder (speed) signal is monitored to detect if the motor is in motion, which results in the “RUN” and “STOP” indicators being activated.

If direction indication (CW/CCW) is desired only when the motor is in motion, a back panel lockout jumper is provided to disable the torque signal.

SYSTEM CONFIGURATION

The 5600 Direction Indicator is attached in series between the dynamometer and dynamometer controller with 2 supplied cables. The controller supplies the power for the LEDs and 5600’s internal electronics.

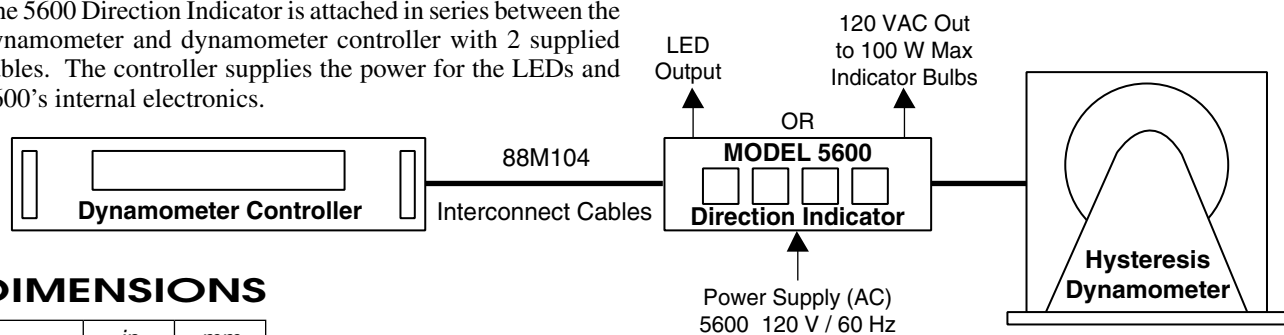

DIMENSIONS

	in	mm
Width	5.75	146
Depth	7.00	178
Height	2.75	70

Due to the continual development of our products, we reserve the right to modify specifications without forewarning.



www.magtrol.com

MAGTROL INC
70 Gardenville Parkway
Buffalo, New York 14224 USA
Phone: +1 716 668 5555
Fax: +1 716 668 8705
E-mail: magtrol@magtrol.com

MAGTROL SA
Centre technologique Montena
1728 Rossens/Fribourg, Switzerland
Phone: +41 (0)26 407 3000
Fax: +41 (0)26 407 3001
E-mail: magtrol@magtrol.ch

Subsidiaries in:
Great Britain
Germany • France
China • India
Worldwide Network
of Sales Agents

